

AM3060 – Filter Bank

Tunable Bandpass 0.32 – 6.5 GHz

Description

AM3060 is a miniature digitally tunable filter bank covering the 320 MHz to 6500 MHz frequency range with adjustable bandwidth in a 12.5mm x 12.5mm package. The device provides a bypassable amplifier stage and ports for a filter bypass path. AM3060 is an excellent front-end for a broadband receiver or transceiver providing the ultimate flexibility of center frequency and bandwidth adjustment while offering high dynamic range and small size, weight, and power consumption (low SWAP).

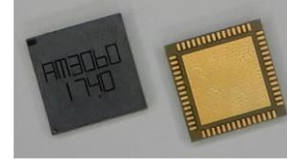

Features

- Digitally Tunable Bandpass Filter
- Independent LP and HP Control
- 4-bit Control
- 6 dB Insertion Loss, Amplifier Bypassed
- 14 dB Gain, Amplifier Enabled
- +40 dBm Input IP3, Amplifier Bypassed
- +3.3V to +5.0V Supply
- +3.0V to +5.0V Control
- 12.5mm QFN Package
- -40C to +85C Operation

Functional Diagram

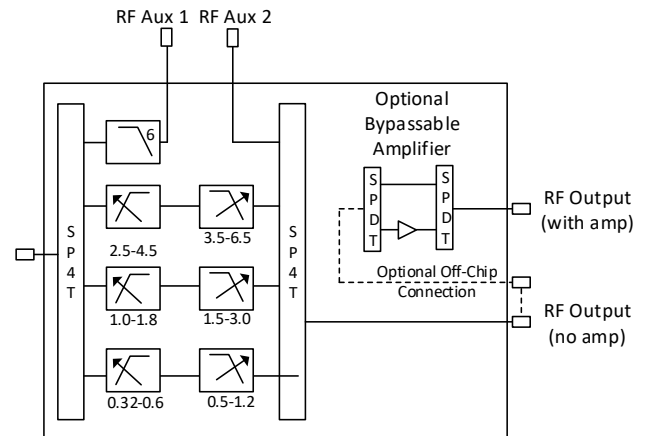

Characteristic Performance

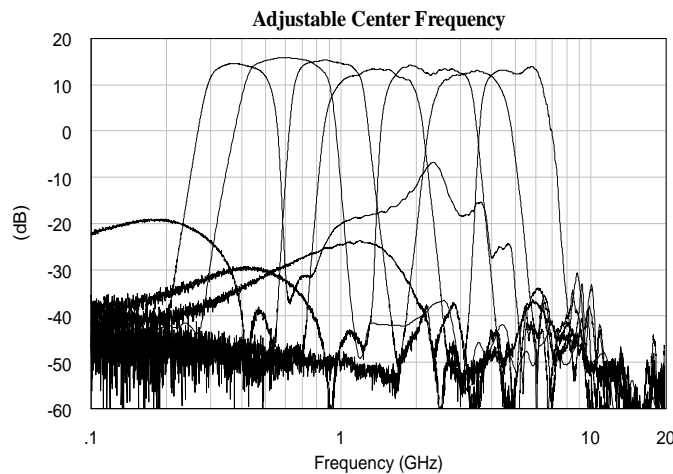

*Note: Band 2 shown

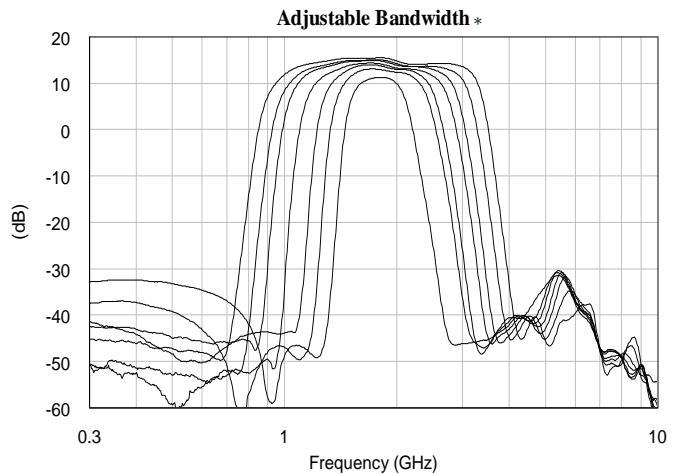

Table of Contents

Description	1	DC Electrical Characteristics.....	7
Features	1	RF Performance.....	7
Functional Diagram	1	State Tables.....	7
Characteristic Performance	1	Typical Performance	9
Revision History	2	Typical Application	12
Pin Layout and Definitions	3	Package Details	13
Specifications	6	Evaluation PC Board	14
Absolute Maximum Ratings.....	6	Related Parts	14
Handling Information.....	6	Component Compliance Information	15
Recommended Operating Conditions ...	6		

Revision History

Date	Revision Number	Notes
March 7, 2018	10	Pinout Table Corrected
September 11, 2018	11	Notes Added to Specifications Section
April 4, 2019	12	Updated to new datasheet format. More comprehensive part data included.

AM3060 – Filter Bank

Tunable Bandpass 0.32 – 6.5 GHz



Pin Layout and Definitions

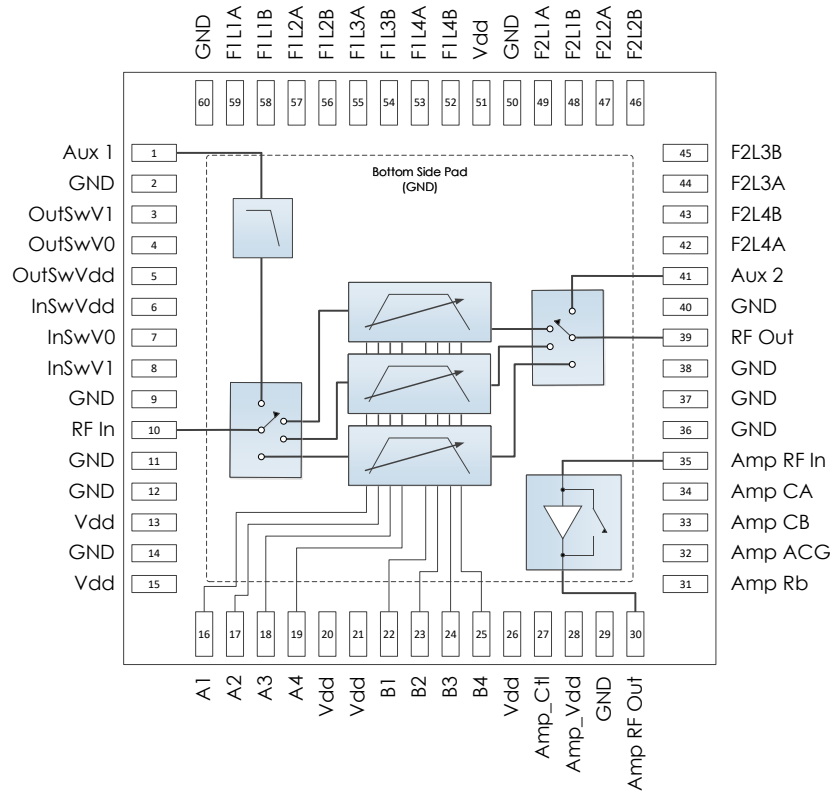

Pin Number	Pin Name	Pin Function
1	RF Aux 1	Optional DC to 6.5 GHz RF port – Pin 41 Return* - 50 Ohms – DC Coupled, External Blocking Capacitor Required
2	GND	Ground – Common
3	OutSwV1	Filter Band Select 1 – Can connect to pin 8, but filter independently
4	OutSwV0	Filter Band Select 0 – Can connect to pin 7, but filter independently
5	OutSwVdd	DC Power Input for Switch 1 – Filter independent from pin 5**
6	InSwVdd	DC Power Input for Switch 2 – Filter independent from pin 4**
7	InSwV0	Filter Band Select 0 – Can connect to pin 4, but filter independently
8	OutSwV1	Filter Band Select 1 – Can connect to pin 3, but filter independently
9	GND	Ground – Common
10	PreSel RF In	Preselector Filter Bank RF Input Port - 50 Ohms – DC Coupled, External Blocking Capacitor Required
11, 12	GND	Ground – Common
13	Vdd	DC Power Input**
14	GND	Ground – Common
15	Vdd	DC Power Input**
16	A1	Highpass Filter Control Bit 1
17	A2	Highpass Filter Control Bit 2
18	A3	Highpass Filter Control Bit 3
19	A4	Highpass Filter Control Bit 4
20, 21	Vdd	DC Power Input.** Filter pins independently

*Can be used for external filtering or connected to return pin through a coupling capacitor for a filter bypass path.
 **Pins 5,6,13,15,20,21,26, and 51 must be driven by the same voltage source. Each line should be individually filtered.

AM3060 – Filter Bank

Tunable Bandpass 0.32 – 6.5 GHz



Pin Layout and Definitions (continued)

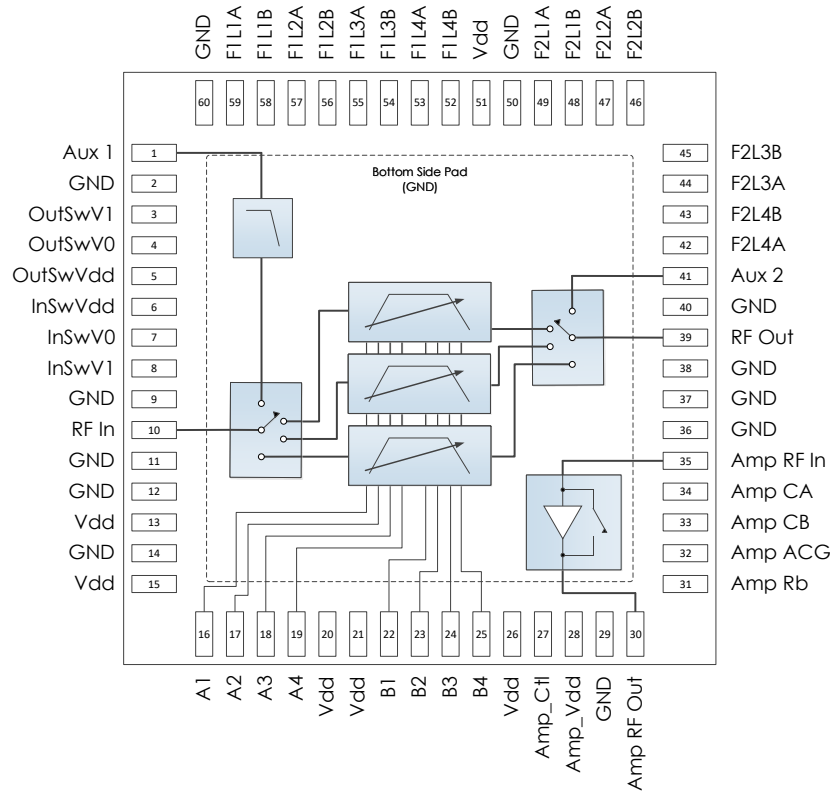

Pin Number	Pin Name	Pin Function
22	B1	Lowpass Filter Control Bit 1
23	B2	Lowpass Filter Control Bit 2
24	B3	Lowpass Filter Control Bit 3
25	B4	Lowpass Filter Control Bit 4
26	Vdd	DC Power Input**
27	Amp_Ctl	Preamplifier Path Control – See state table for control information.
28	Amp_Vdd	DC Power Input for Amplifier
29	GND	Ground – Common
30	Amp RF Out / Vd	Amplifier Output and DC Power Input – 50 Ohms – DC Coupled, External DC Block Required.***
31	Amp Rb	Amplifier Bias Setting – leave open for normal operation or add a do not install resistor to ground
32	Amp ACG	Amplifier AC Ground – connect 0.1µF capacitor to ground
33	Amp CB	External Capacitor Connection 1 – connect to pin 34 through a 0201 0.1µF capacitor keeping connections as short as possible.
34	Amp CA	External Capacitor Connection 2 – connect to pin 33 through a 0201 0.1µF capacitor keeping connections as short as possible.
35	Amp RF In	Amplifier Input Port – 50 Ohms – DC Coupled, External DC Block Required
36 – 38	GND	Ground – Common
39	Presel RF Out	Preselector Filter Bank RF Output Port - 50 Ohms – DC Coupled, External Blocking Capacitor Required

*Can be used for external filtering or connected to return pin through a coupling capacitor for a filter bypass path.

**Pins 5,6,13,15,20,21,26, and 51 must be driven by the same voltage source. Each line should be individually filtered.

***Voltage on pin 30 must be less than the voltage on pin 28. See application circuit for recommended connection.

AM3060 – Filter Bank

Tunable Bandpass 0.32 – 6.5 GHz



Pin Layout and Definitions (continued)

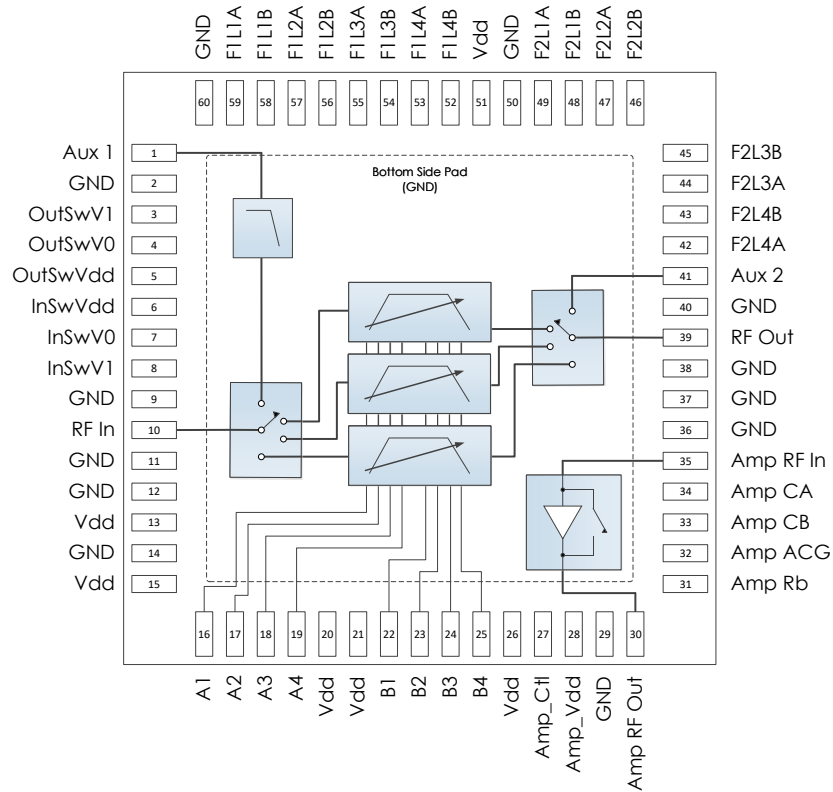

Pin Number	Pin Name	Pin Function
40	GND	Ground – Common
41	RF Aux 2	Optional DC to 6.5 GHz RF port – Pin 1 Return* - 50 Ohms – DC Coupled, External Blocking Capacitor Required
42	F2L4A	Filter 2 L4 Connection A
43	F2L4B	Filter 2 L4 Connection B
44	F2L3B	Filter 2 L3 Connection A
45	F2L3A	Filter 2 L3 Connection B
46	F2L2B	Filter 2 L2 Connection B
47	F2L2A	Filter 2 L2 Connection A
48	F2L1B	Filter 2 L1 Connection B
49	F2L1A	Filter 2 L1 Connection A
50	GND	Ground – Common
51	Vdd	DC Power Input**
52	F1L4B	Filter 1 L4 Connection B
53	F1L4A	Filter 1 L4 Connection A
54	F1L3B	Filter 1 L3 Connection B
55	F1L3A	Filter 1 L3 Connection A
56	F1L2B	Filter 1 L2 Connection B
57	F1L2A	Filter 1 L2 Connection A
58	F1L1B	Filter 1 L1 Connection B
59	F1L1A	Filter 1 L1 Connection A
60	GND	Ground – Common
Bottom Pad	GND	Ground – Common

**Pins 5,6,13,15,20,21,26, and 51 must be driven by the same voltage source. Each line should be individually filtered.

AM3060 – Filter Bank

Tunable Bandpass 0.32 – 6.5 GHz

Specifications

Absolute Maximum Ratings

	Minimum	Maximum
Amplifier Voltage		+ 3.6 V
Supply Voltage	-0.3 V	+6 V
RF Input Power		+17 dBm
Operating Junction Temperature	-40 C	+150 C
Storage Temperature Range	-50 C	+150 C

Note: Any device operation beyond the Absolute Maximum Ratings may result in permanent damage to the device. The values listed in this table are extremes and do not imply functional operation of the device at these or any other conditions beyond what is listed under Recommended Operating Conditions. Any part subjected to conditions outside of what is recommended for an extended amount of time may suffer from reliability concerns.

Handling Information

	Minimum	Maximum
Storage Temperature Range (Recommended)	-50 C	+125 C
Moisture Sensitivity Level	MSL 3	



Atlanta Micro products are electrostatic sensitive.
Follow safe handling practices to avoid damage

Recommended Operating Conditions

	Minimum	Typical	Maximum
Amplifier Voltage	+3.1 V	+3.3 V	+3.5 V
Supply Voltage	+2.7 V	+5.0 V	+5.2 V
Operating Case Temperature	-40 C		+85 C
Operating Junction Temperature	-40 C		+125 C

AM3060 – Filter Bank

Tunable Bandpass 0.32 – 6.5 GHz

DC Electrical Characteristics

(T = 25 °C unless otherwise specified)

Parameter	Testing Conditions	Minimum	Typical	Maximum
Amplifier Voltage (V _{amp})		+3.1 V	+3.3 V	+3.5 V
Supply Voltage (V _{dd})		+2.7 V	+5.0 V	+5.2 V
DC Amplifier Current			60 mA	
DC Supply Current	V _{dd} = +5.0 V		10 mA	
Power Dissipated	Amplifier Enabled		0.25 W	
	Amplifier Bypassed		0.05 W	
Logic Level Low		-0.1 V		+0.4 V
Logic Level High		+2.2 V		+V _{dd}

RF Performance

(T = 25 °C unless otherwise specified)

Parameter	Testing Conditions	Minimum	Typical	Maximum
Frequency Range		2 MHz		6500 MHz
Filter Range		320 MHz		6500 MHz
Gain	Amplifier Enabled		14 dB	
Insertion Loss	Amplifier Bypassed		6 dB	
Noise Figure	Amplifier Enabled		7 dB	
	Amplifier Bypassed		6 dB	
Input IP3	Amplifier Enabled		+14 dBm	
	Amplifier Bypassed		+40 dBm	
Input IP2	Amplifier Enabled		+50 dBm	
	Amplifier Bypassed		+70 dBm	
Input Return Loss			10 dB	
Output Return Loss			10 dB	

State Tables

Out/InSwV1	Out/InSwV0	Selected Filter Band
Low	Low	Band 2 – 1.0 to 3.0 GHz
Low	High	Band 3 – 2.5 to 6.5 GHz
High	Low	Band 1 – 0.32 to 1.2 GHz
High	High	Band 0 – Bypass

Amp_Ctl	Amplifier State
Low	Amplifier Bypassed
High	Amplifier Enabled

AM3060 – Filter Bank

Tunable Bandpass 0.32 – 6.5 GHz

State Tables (Continued)

High Pass Filter Typical Cutoff Frequencies (GHz)

A4	A3	A2	A1	Band 1	Band 2	Band 3
Low	Low	Low	Low	0.330	1.00	2.50
Low	Low	Low	High	0.332	1.01	2.53
Low	Low	High	Low	0.338	1.02	2.56
Low	Low	High	High	0.341	1.03	2.59
Low	High	Low	Low	0.354	1.06	2.61
Low	High	Low	High	0.359	1.08	2.64
Low	High	High	Low	0.373	1.10	2.70
Low	High	High	High	0.381	1.12	2.74
High	Low	Low	Low	0.443	1.14	2.85
High	Low	Low	High	0.448	1.16	2.93
High	Low	High	Low	0.463	1.20	3.06
High	Low	High	High	0.473	1.25	3.20
High	High	Low	Low	0.508	1.37	3.26
High	High	Low	High	0.531	1.47	3.47
High	High	High	Low	0.618	1.60	3.84
High	High	High	High	0.717	1.82	4.36

Low Pass Typical Cutoff Frequencies (GHz)

B4	B3	B2	B1	Band 1	Band 2	Band 3
Low	Low	Low	Low	0.493	1.50	3.50
Low	Low	Low	High	0.503	1.55	3.60
Low	Low	High	Low	0.518	1.59	3.68
Low	Low	High	High	0.530	1.65	3.79
Low	High	Low	Low	0.552	1.70	3.89
Low	High	Low	High	0.567	1.78	4.04
Low	High	High	Low	0.587	1.84	4.15
Low	High	High	High	0.604	1.92	4.31
High	Low	Low	Low	0.661	2.00	4.54
High	Low	Low	High	0.690	2.10	4.74
High	Low	High	Low	0.731	2.20	4.97
High	Low	High	High	0.767	2.33	5.22
High	High	Low	Low	0.850	2.49	5.47
High	High	Low	High	0.915	2.67	5.84
High	High	High	Low	1.032	2.86	6.22
High	High	High	High	1.200	3.12	6.75

AM3060 – Filter Bank

Tunable Bandpass 0.32 – 6.5 GHz

Typical Performance

(T = 25 °C and Amplifier Bypassed unless otherwise specified. Only some states shown for simplicity.)

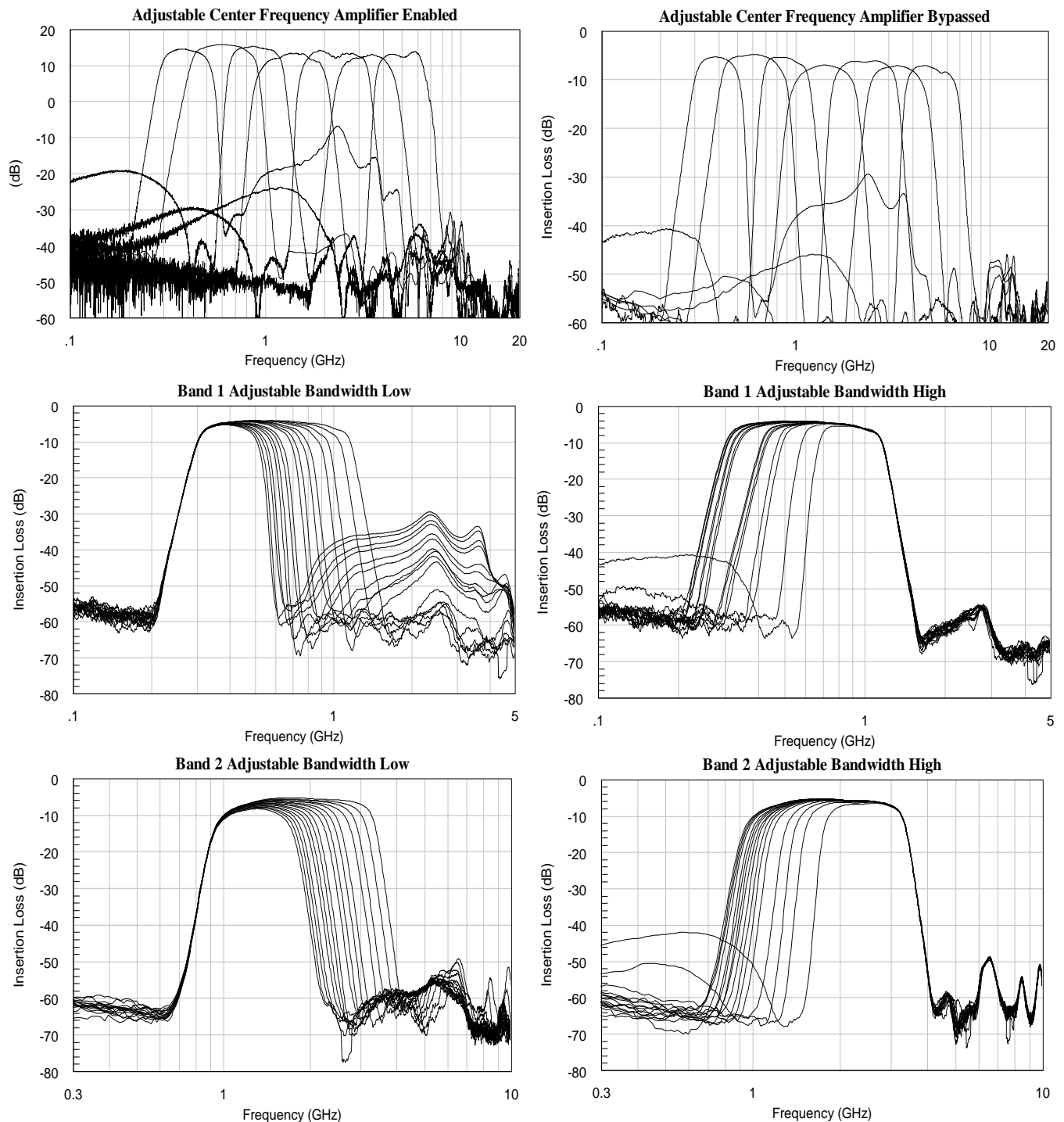

AM3060 – Filter Bank

Tunable Bandpass 0.32 – 6.5 GHz

Typical Performance (continued)

(T = 25 °C and Amplifier Bypassed unless otherwise specified. Only some states shown for simplicity.)

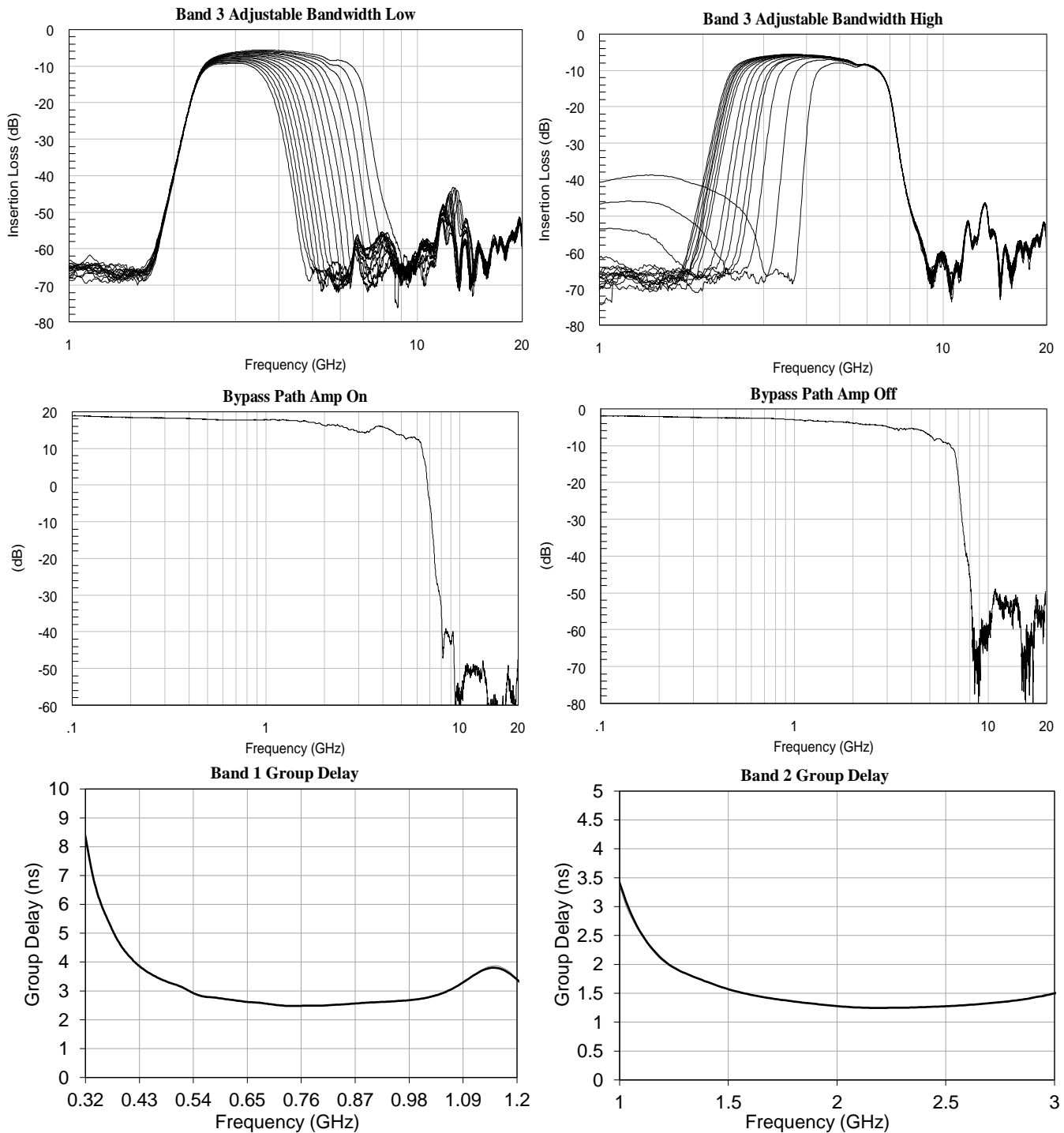

AM3060 – Filter Bank

Tunable Bandpass 0.32 – 6.5 GHz

Typical Performance (continued)

(T = 25 °C and Amplifier Bypassed unless otherwise specified.)

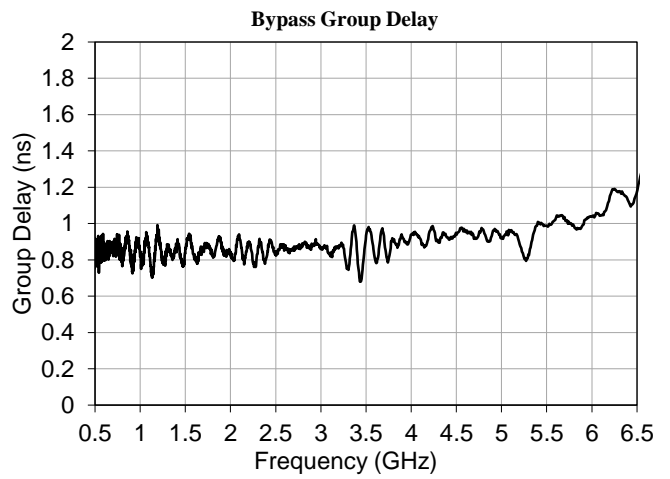
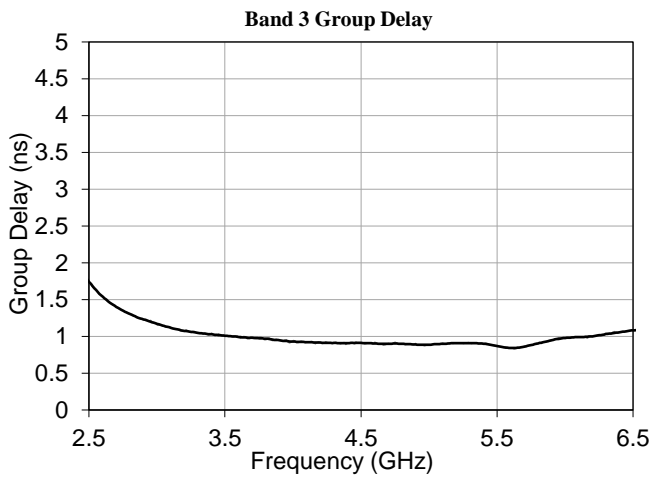

AM3060 – Filter Bank

Tunable Bandpass 0.32 – 6.5 GHz



Typical Application

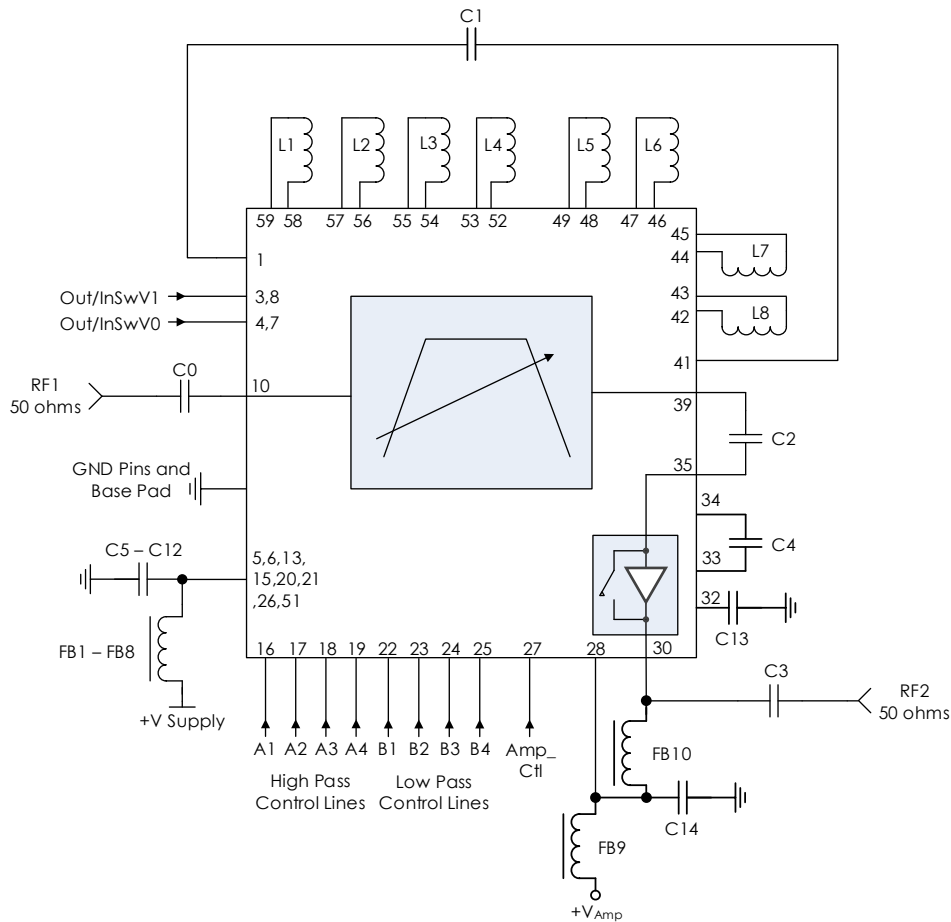

Recommended Component List (or equivalent):

Part	Value	Part Number	Manufacturer
C0 – C4	0.1µF	0201BB104KW160	Passives Plus
C5-C14	0.1µF	C1005X7R1H104K050BB	TDK
FB1-10		MMZ1005A222E	TDK
L1, L4	13 nH	0402HP-13NXGLW	Coilcraft
L2, L3	9.0 nH	0402HP-9N0XGLW	Coilcraft
L5, L8	5.6 nH	0402HP-5N6XGLW	Coilcraft
L6, L7	6.2 nH	0402HP-6N2XGLW	Coilcraft

Notes:

1. RC filtering on the control lines is recommended to prevent digital noise from coupling to the RF path.
 - a. Select control line RC filter values based on desired logic source decoupling and switching speed

AM3060 – Filter Bank

Tunable Bandpass 0.32 – 6.5 GHz

Package Details

Package Drawing

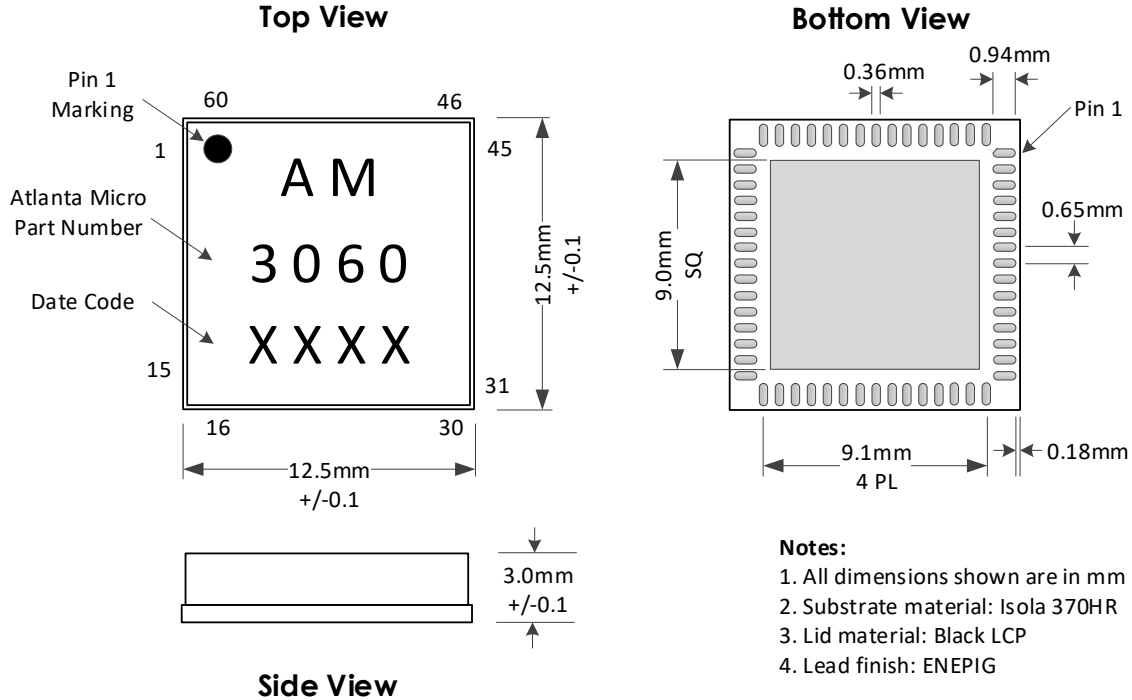

Recommended Footprint

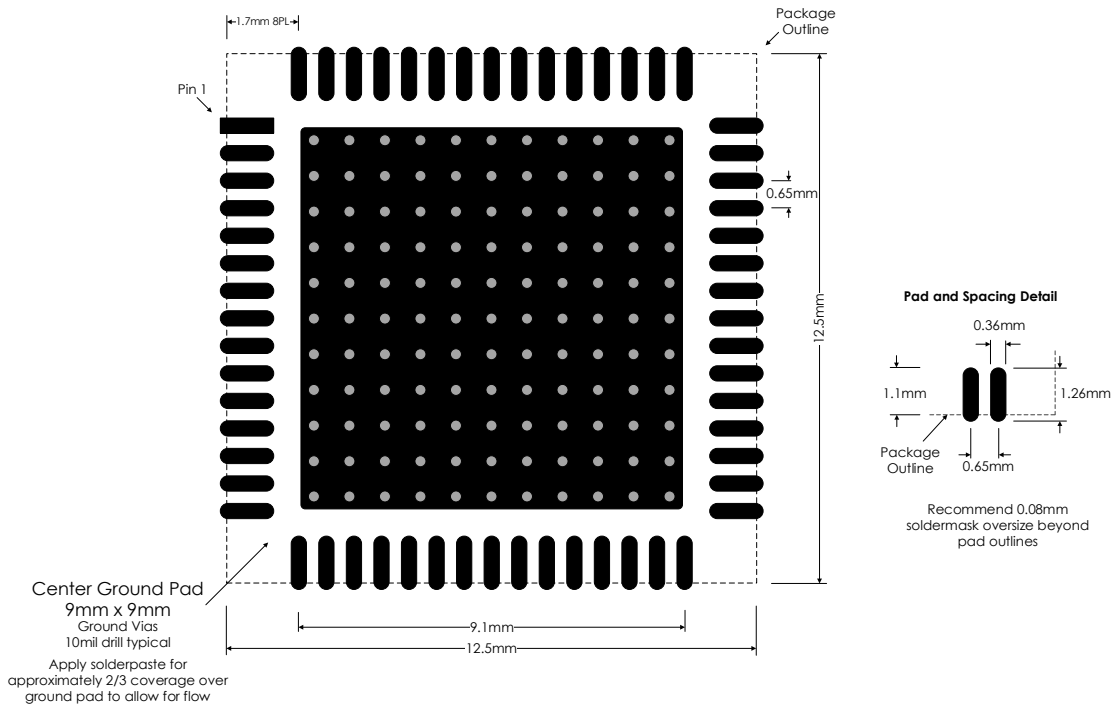

AM3060 – Filter Bank

Tunable Bandpass 0.32 – 6.5 GHz

Evaluation PC Board

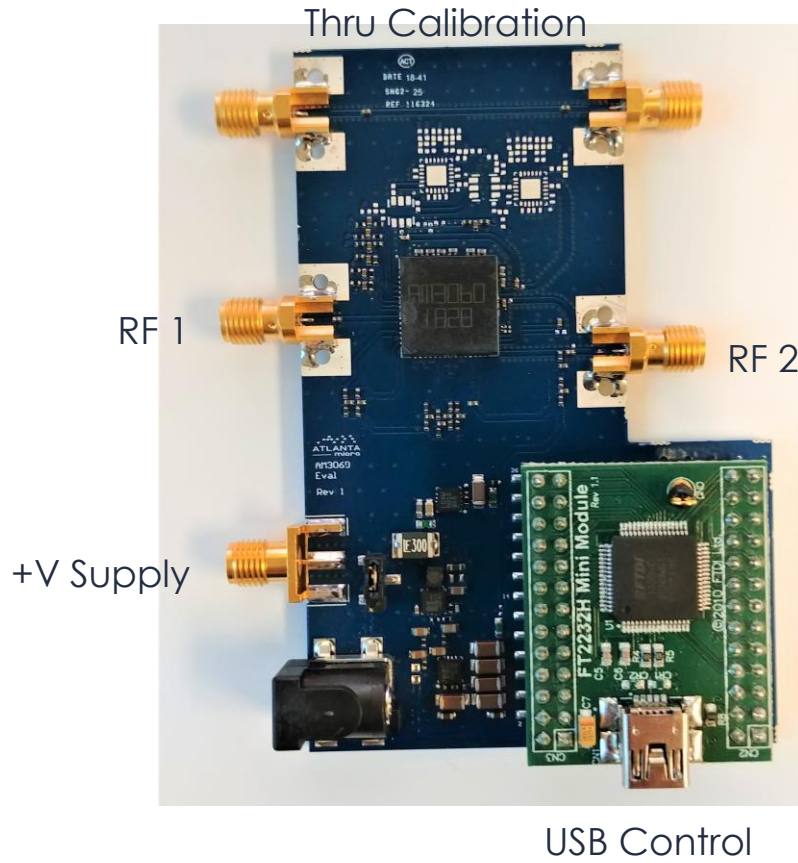

Related Parts

Part Number	Description	
AM3023B	100 MHz to 6 GHz	Switched Sub-Octave Filter Bank
AM3024B	100 MHz to 6 GHz	Switched Sub-Octave Filter Bank
AM3025A	400 MHz to 6 GHz	Switched Sub-Octave Filter Bank
AM3089	2 GHz to 18 GHz	Switched Analog Tuned Filter Bank
AM3063	6 GHz to 18 GHz	Digitally Tunable Bandpass Filter Bank
AM3064	1 GHz to 6.5 GHz	Digitally Tunable Bandpass Filter Bank
AM3065	6 GHz to 12 GHz	Digitally Tunable Bandpass Filter
AM3066	18 GHz to 26.5 GHz	Digitally Tunable Bandpass Filter Bank
AM3090	100 MHz to 450 MHz	Digitally Tunable Bandpass Filter

AM3060 – Filter Bank

Tunable Bandpass 0.32 – 6.5 GHz



Component Compliance Information

RoHS: Atlanta Micro, Inc. hereby certifies that all products comply with the EC Directive 2011/65/EC on the Restriction of Hazardous Substances, commonly known as RoHS II. All products supplied by Atlanta Micro shall be compliant with the European Directive 2011/65/EC based on the following substance list.

Substance List	Allowable Maximum Concentration
Lead (Pb)	<1000 PPM (0.1% by weight)
Mercury (Hg)	<1000 PPM (0.1% by weight)
Cadmium (Cd)	<75 PPM (0.0075% by weight)
Hexavalent Chromium (CrVI)	<1000 PPM (0.1% by weight)
Polybrominated Biphenyls (PBB)	<1000 PPM (0.1% by weight)
Polybrominated Diphenyl ethers (PBDE)	<1000 PPM (0.1% by weight)
Decabromodiphenyl Deca BDE	<1000 PPM (0.1% by weight)

REACH: Atlanta Micro, Inc. neither uses nor intentionally adds any of the substances considered to be a Substance of Very High Concern (SVHC) as defined by the EU Regulation (EC) No. 1907-2006 on Registration, Evaluation, Authorization, and Restriction of Chemicals (REACH).

Conflict Materials: Atlanta Micro does not knowingly use materials that are sourced from the Democratic Republic of Congo (DRC) or any other known conflict regions. Atlanta Micro's supply chain is comprised of sources that are both environmentally and socially responsible. We periodically review this requirement with our vendors to ensure continued compliance.

Atlanta Micro takes its responsibility as a global partner seriously and will use due diligence within our supply chain to ensure all standards are met to the best of our knowledge.