

5 to 20 GHz High OIP2 LNA**Product Description**

ATEK178P4 is a GaAs MMIC Wideband High Output IP2 Low Noise Amplifier operating from 5 to 20 GHz.

The ATEK178P4 provides a high gain of 17dB with a corresponding low noise figure of 4.3dB and a high OIP3 of +28dBm. The LNA has a very high 2nd order intercept of +60dBm that results in greater than 60dBc suppression of the second harmonic output with 0 dBm output power. This allows users to minimize unwanted harmonic signal generation while providing low distortion amplification in microwave signal chains.

The ATEK178P4 LNA is housed in a compact 4x4 mm SMD package with input and output matched to 50 ohms internally.

Evaluation Board, bare die, custom package, and module options are available upon request.

Product Features

- Frequency Range: 5 - 20 GHz
- OIP2: +60 dBm
- OIP3: +28dBm
- P1dB: +20dBm
- Gain: 17 dB
- Noise Figure: 4.5 dB
- VD BIAS: +4V @ 160ma
- 4x4 mm compact size

Applications

- Wideband Receivers, SDRs
- Microwave Radio
- Test and Measurement
- EW / ECM / C-UAS
- Military and Commercial Radar

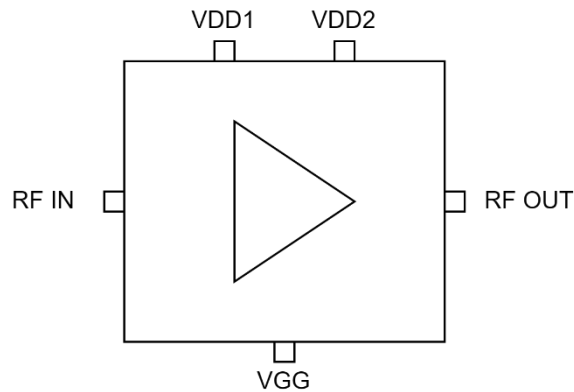
Functional Block Diagram

Electrical Specifications

Conditions unless otherwise specified: $V_{DD1} = V_{DD2} = V_{GG} = 4\text{ V}$, Typical, $T = 25\text{ C}$, CW.

Parameter		Min	Typ	Max	Units
Operational Frequency Range		5		20	GHz
Gain	5 GHz		16.6		dB
	8 GHz		17.5		
	12 GHz		16.8		
	16 GHz		16.7		
	20 GHz		14.5		
IP2	5 GHz		63		dBm
	8 GHz		58		
	12 GHz		63		
	16 GHz		64		
	18 GHz		74		
Noise Figure	5 GHz		6.2		dB
	8 GHz		4.5		
	12 GHz		4.3		
	16 GHz		4.5		
	20 GHz		5.3		
Isolation	5 GHz		51		dB
	8 GHz		49		
	12 GHz		48		
	16 GHz		45		
	20 GHz		47		
Input Return Loss			-12		dB
Output Return Loss			-13		dB
Output IP3			28		dBm
Output P1dB			20		dBm
Psat			19.5		dBm
DC Supply Voltage ($V_{dd1} = V_{dd2}$)			4		V
DC Supply Current ($I_{dd1} + I_{dd2}$)			160		mA
DC Gate Voltage (V_{gg})			4		V
DC Gate Current (I_{gg})			0.5		mA
Operating Temperature		-40		85	°C

Typical Performance Plots

Conditions unless otherwise specified: $V_{DD1} = V_{DD2} = V_{GG} = 4\text{ V}$, Typical, $T = 25\text{ C}$, CW.

Gain

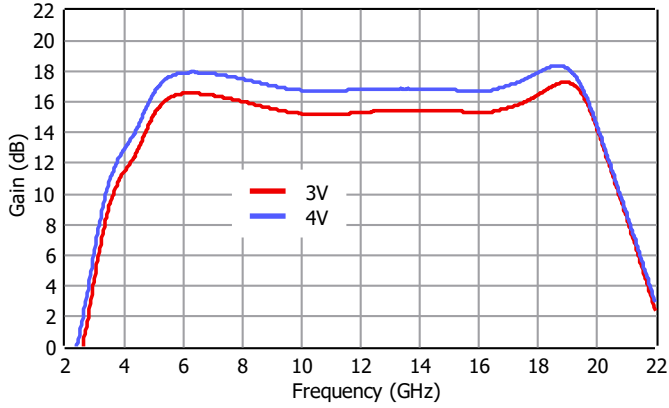

Input Return Loss

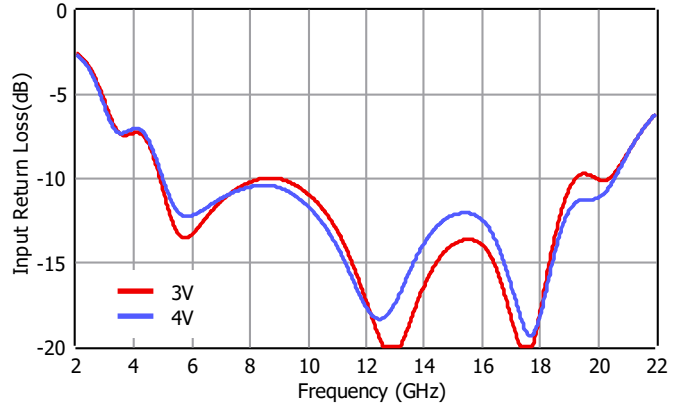

Output Return Loss

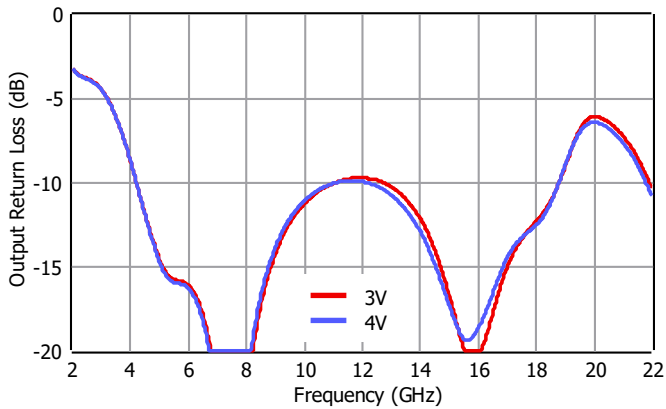

IP2 at Pout = 0dBm/tone

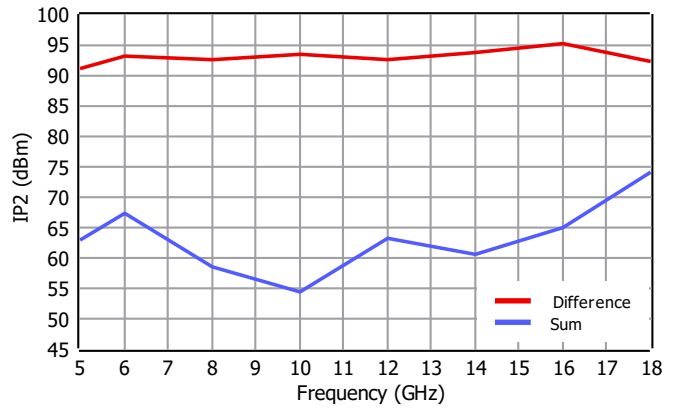

IP3 at Pout = 0dBm/tone

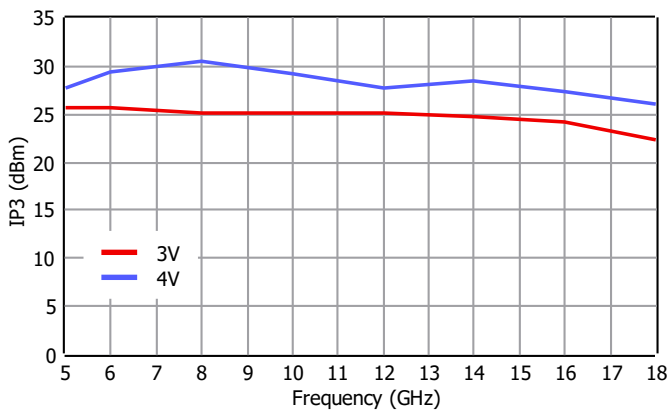

Noise Figure

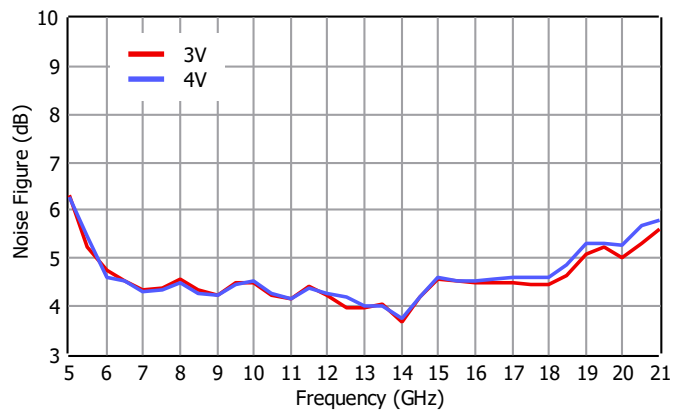

Typical Performance Plots

Conditions unless otherwise specified: $V_{DD1} = V_{DD2} = V_{GG} = 4\text{ V}$, Typical, $T = 25\text{ C}$, CW.

P1dB

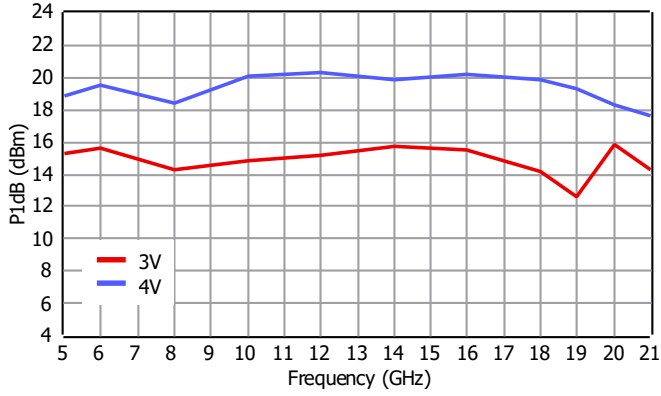

Psat

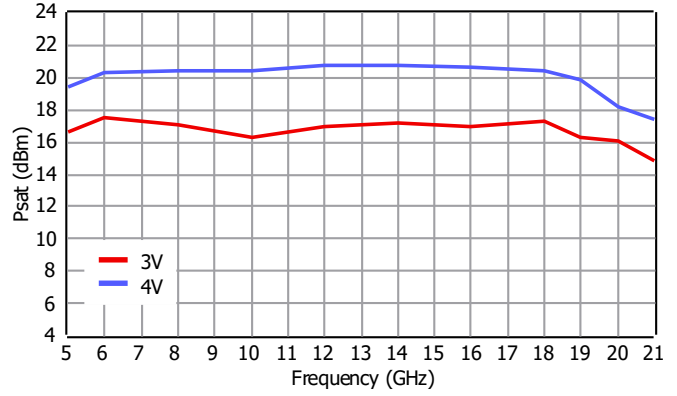

Current vs Output Power at 10 GHz

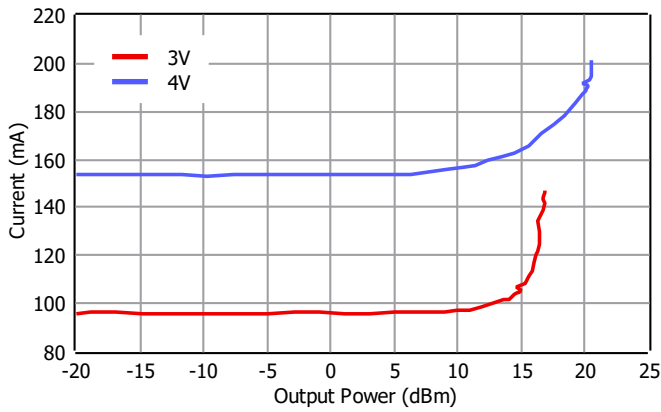

Second Harmonic at Pout = 0dBm/tone

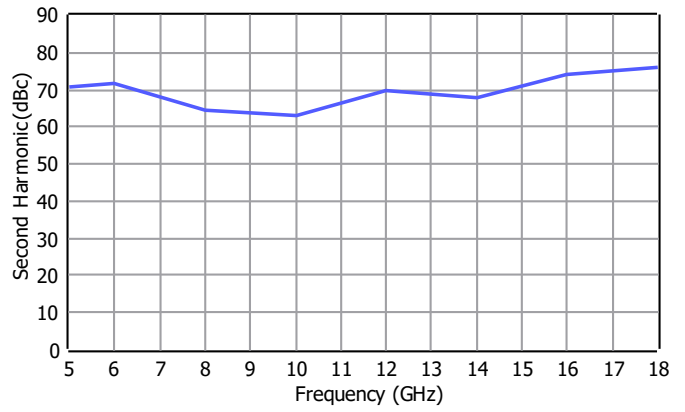

Pin Description

Top View

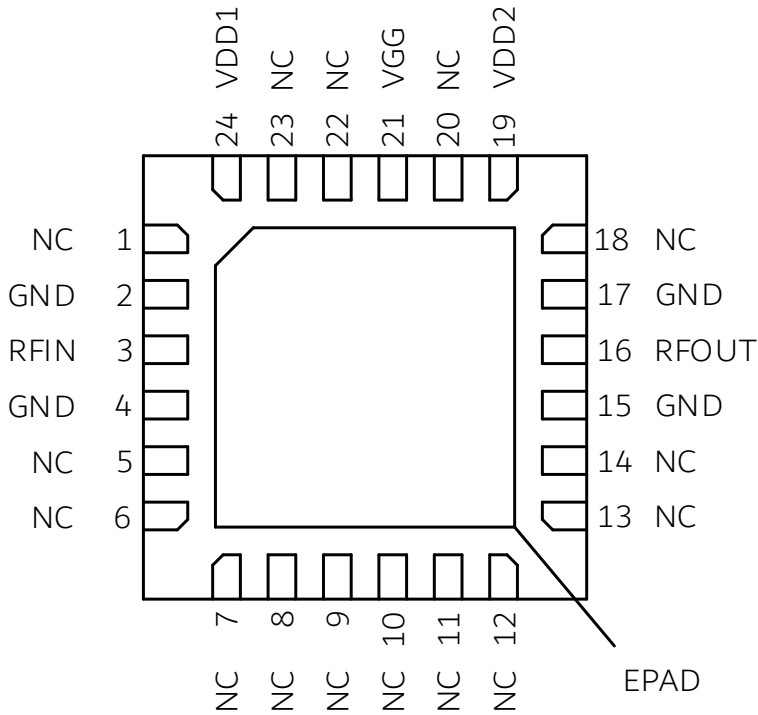

Pin Number	Pin Name	Description
3	RF IN	RF input pin. AC Coupled.
16	RF OUT	RF output pin. AC Coupled.
24	VDD1	Vdd bias pin.
19	VDD2	Vdd bias pin.
21	VGG	Vg bias pin.
1, 5-14, 18, 20, 22, 23	NC	These pins are not internally connected. Can be grounded on the PCB.
2, 4, 15, 17	GND	Ground.
25	EPAD	Exposed Pad on the bottom of the package should be connected to ground with multiple number of vias to reduce the inductance to the GND.

Applications Information

Signal entering from RF IN goes to RF OUT with an amplification.
A typical application schematic to operate the amplifier is given below.

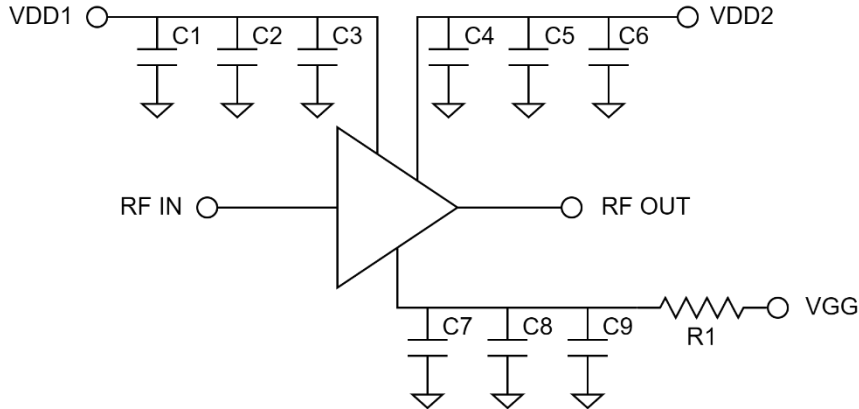

C1, C2, C3, C4, C5, C6, C7, C8 and C9 are used to filter out the ripples and unwanted signals coming from the Vdd supply and Vg supply. Using additional capacitors in parallel to C1, C2, C3, C4, C5, C6, C7, C8 and C9 will improve this filtering. If this filtering is of no concern, then the amplifier can be operated without C1, C2, C3, C4, C5, C6, C7, C8 and C9.

R1 is a gate resistor.

Small signal data plots are gathered with probe PCB measurements to generate plots shown in this document.

Large signal and noise figure data are generated with connectorized evaluation of PCB measurements. Then the PCB trace and connector transition losses are de-embedded, to generate plots shown in this document.

The NC pins of the Amplifier are connected to the GND on the PCBs used to generate the plots shown in this document.

Absolute Maximum Ratings

Parameter	Value/Range
Supply Voltage (Vdd)	+4.5V
RF Input Power (Vdd = +4.0V)	+17dBm
Channel Temperature	+175 °C
Thermal Resistance	120°C/W
Power Dissipation (Ta=85 °C)	0.75W
Storage Temperature	-55 to +125°C
Operating Temperature	-40 to +85 °C

Operation of this device outside the parameter ranges given above may cause damage. These conditions should not be applied simultaneously.

Mechanical and Marking Information

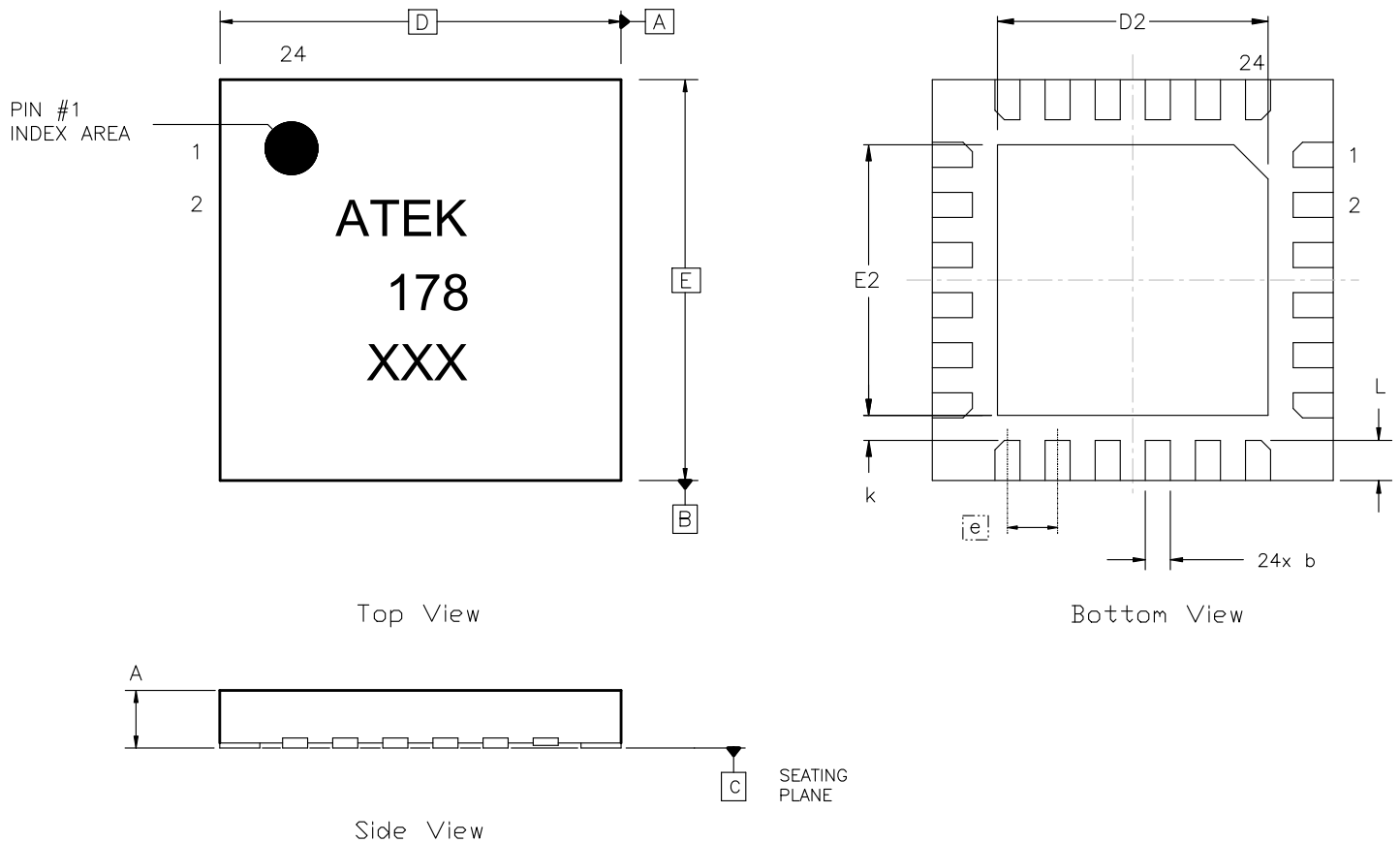

NOTES:
1) ALL DIMENSIONS IN MM
2) MARKING XXX INDICATES INTERNAL LOT CODE

SYMBOL	MIN	MAX	SYMBOL	MIN	MAX
A, V	0.80	1.00	E2	2.60	2.80
b	0.18	0.30	e	0.50	BSC
D	4.00	BSC	k	0.20	-
D2	2.60	2.80	L	0.35	0.45
E	4.00	BSC			

Handling Precautions



Caution!
ESD-Sensitive Device
Handle Accordingly

Contact Information

For the latest specifications, additional product information, support, and sales.

Web: www.atekmidas.com

Tel: +90-212-483-71-67

Email: support@atekmidas.com

Notice

This document and its contents are property of ATEK MIDAS. ATEK MIDAS has carefully reviewed the product specification information herein, and it is believed to be accurate and reliable. However, no responsibility is assumed for inaccuracies or errors, and the information within may be changed at any time without prior notice. Use of this information and/or any of our products does not convey to the user any patent rights or licenses. ATEK MIDAS products are designed to be used only within the electrical and environmental limits published in their respective data sheets or custom quoted specifications. ATEK MIDAS does not authorize the use of any of its products beyond the current published data sheet limits. Such use beyond the currently published electrical and/or environmental data sheet limits voids all ATEK MIDAS warranties. ATEK MIDAS reserves the right to change component circuitry, package material, assembly/test/inspect processes, specifications or other information at any time without prior notice. ATEK MIDAS shall have no responsibility for the customer's products, customer applications, and actions of the customer related to this product.

Revisions

Revision No	Revision Date	Revision Reason	Section / Page No
0.1	16.05.2026	Initial Release	
0.2	05.06.2026	Product Release, Format & Content Fixed	