

DC to 18 GHz 15W Reflective SPDT GaN Switch

Product Description

The ATEK273AN4 is a wideband high power GaN MMIC SPDT reflective switch offering 15W power handling operating from DC to 18 GHz. The switch is fabricated on a Gallium Nitride on SiC process to enable high operating output power levels while maintaining fast switching speeds and minimal loss.

The ATEK273AN4 exhibits insertion loss of 1.2dB while switching 15W over the 0.5 to 18 GHz frequency range with 0.3dB compression. The switch has excellent return loss and provides 40dB typical isolation.

The ATEK273AN4 is housed in a compact 4x4mm SMD package with input and output matched to 50 ohms internally.

Evaluation Board, bare die, custom package, and module options are available upon request.

Product Features

- Frequency Range: DC to 18 GHz
- Insertion Loss: 1.2 dB
- Isolation: 40dB
- 0.3dB Compression: 15 W
- Control Voltage: 0/-40V
- 4x4 mm Compact Size

Applications

- Wideband Receivers, SDRs
- Telecommunication
- Test and Measurement
- SATCOM
- EW / ECM / C-UAS

Functional Block Diagram

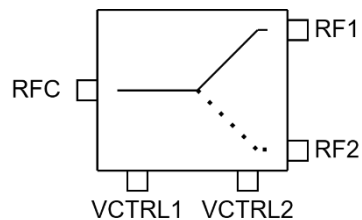

DC to 18 GHz 15W Reflective SPDT GaN Switch
Electrical Specifications

 Conditions unless otherwise specified: $V_{CTRL} = 0/-40V$, Typical, $T = 25\text{ C}$, CW.

Parameter		Min	Typ	Max	Units
Operational Frequency Range		LF		18	GHz
Insertion Loss	0.01 GHz		0.45		dB
	4 GHz		0.8		
	10 GHz		1.3		
	18 GHz		2.1		
Isolation	0.01 GHz		90		dB
	4 GHz		50		
	10 GHz		37		
	18 GHz		34		
Input Return Loss			-10		dB
Output Return Loss			-12		dB
Input IP3			TBD		dBm
Loss Compression at +41.76dBm (15W)			0.3		dB
Switching Speed	On		TBD		ns
	50% V_{ctrl} to 90% of RF Output	Off	TBD		
0.1dB Settling Time			TBD		ns
Control Voltage (CTRL)	Low		0		V
	High		-40		
Control Current			0.5		mA
Operating Temperature		-40		85	°C

DC to 18 GHz 15W Reflective SPDT GaN Switch

Typical Performance Plots

Conditions unless otherwise specified: $V_{CTRL} = 0/-40V$, Typical, $T = 25\text{ C}$, CW.

Insertion Loss

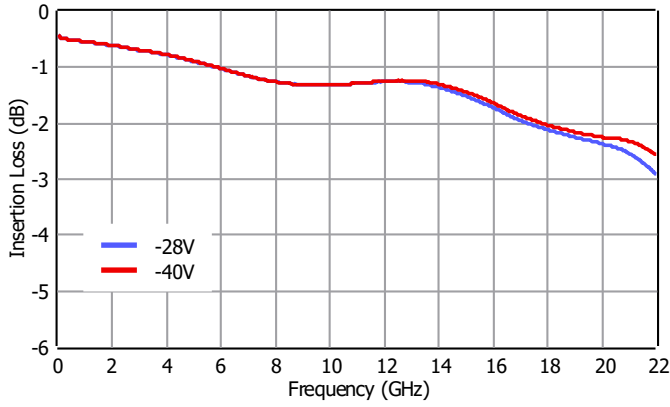

Return Loss at -28V

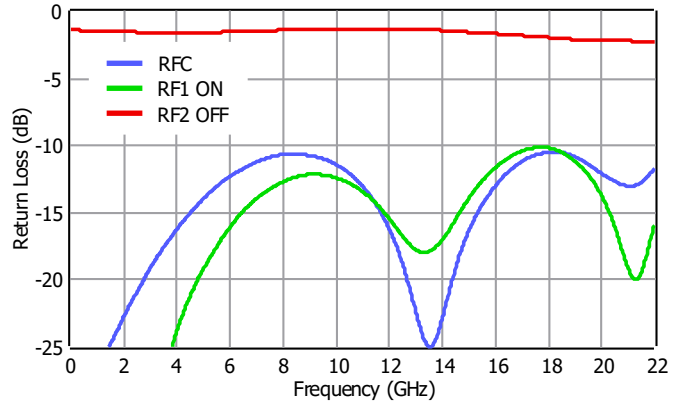

Return Loss at -40V

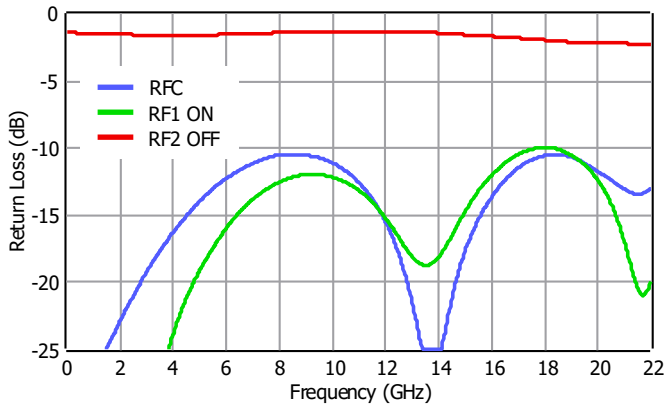

Isolation

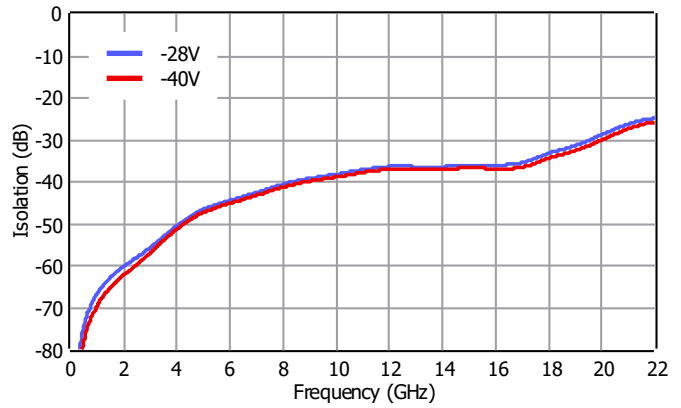

Loss Compression, Pin = 40.5dBm

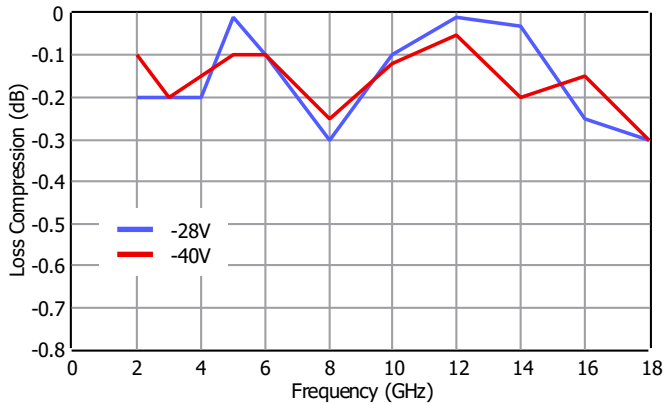

Loss Compression, Pin = 41.5dBm

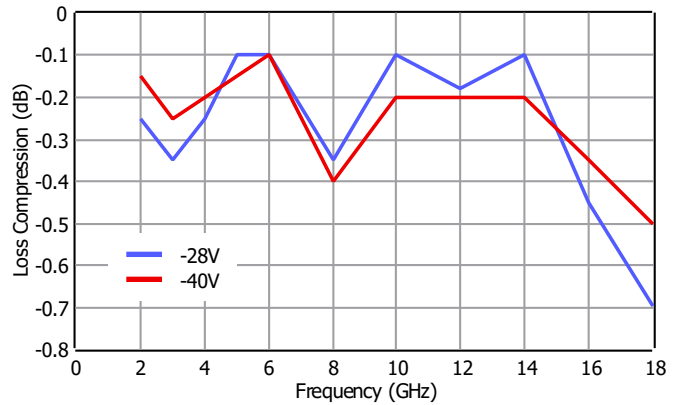

DC to 18 GHz 15W Reflective SPDT GaN Switch

Pin Description

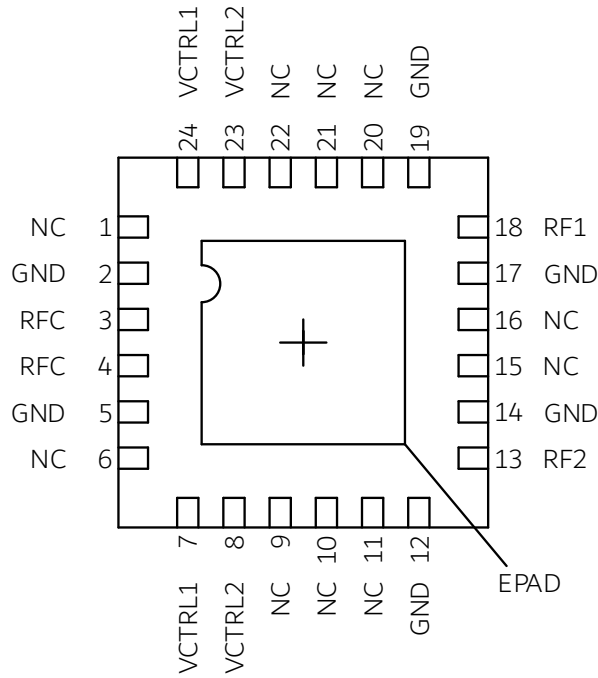

Top View

Pin Number	Pin Name	Description
3, 4	RFC	RF input pin. If the DC voltage level on RF lines is not equal to 0 V, an external DC block capacitor is required.
18	RF1	RF output pin. If the DC voltage level on RF lines is not equal to 0 V, an external DC block capacitor is required.
13	RF2	RF output pin. If the DC voltage level on RF lines is not equal to 0 V, an external DC block capacitor is required.
7, 24	VCTRL1	Control pin.
8, 23	VCRTL2	Control pin.
1, 6, 9-11, 15, 16, 20-22	NC	These pins are not internally connected. Can be grounded on the PCB.
2, 5, 12, 14, 17, 19	GND	Ground.
17	EPAD	Exposed Pad on the bottom of the package should be connected to ground with multiple number of vias to reduce the inductance to the GND.

Control Interface

CTRL1	CTRL2	Filter Bank State
LOW	HIGH	RF1
HIGH	LOW	RF2

DC to 18 GHz 15W Reflective SPDT GaN Switch

Applications Information

Signal entering from RFC goes to RF1 or RF2 depending on the switch state set by the user. The switch ports are bi-directional.

A typical application schematic to operate the SPDT switch is given below.

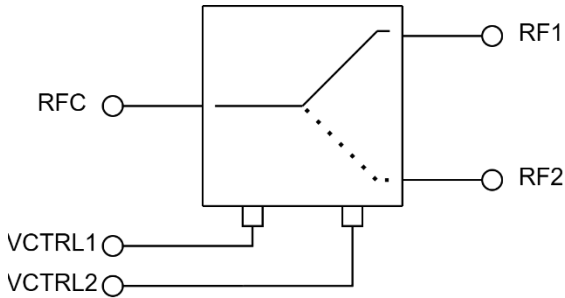

VCTRL1 and VCTRL2 signals are used for setting the switch state.

If needed, to filter out the ripples and unwanted signals on the external CTRL signals, a low pass filter in series R, shunt C configuration can be implemented on the CTRL lines. Note that external RC filtering limits the state switching speed of the SPDT.

Small signal data plots are gathered with probe PCB measurements to generate plots shown in this document.

Large signal data are generated with connectorized evaluation of PCB measurements. Then the PCB trace and connector transition losses are de-embedded, to generate plots shown in this document.

NC pins of the SPDT are connected to the GND on the EVB used to generate the plots shown in this document.

DC to 18 GHz 15W Reflective SPDT GaN Switch

Absolute Maximum Ratings

Parameter	Value/Range
Control Voltage (VCTRL1, VCTR2)	-50.0V / 0.0V
Control Current (ICTRL1, ICTR2)	5mA
RF Input Power (-40, 0V = VCTRL1, VCTR2)	+43dBm
Channel Temperature TJMAX	275°C
Power Dissipation	7.6W
Operating Temperature	-40 to +85 °C
Storage Temperature	-55 to +125 °C

Operation of this device outside the parameter ranges given above may cause damage. These conditions should not be applied simultaneously.

Mechanical and Marking Information

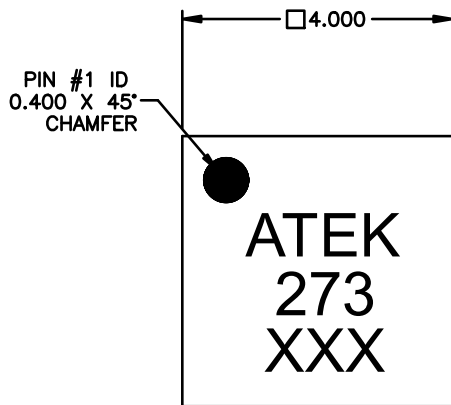

TOP VIEW

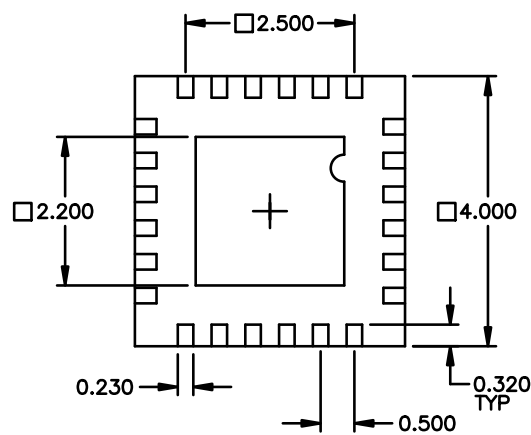

BOTTOM VIEW

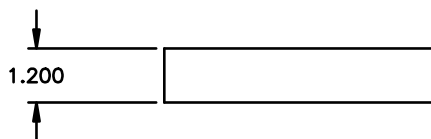

SECTION A-A

NOTES

1. ALL DIMENSIONS IN MM
2. MARKING XXX INDICATES INTERNAL LOT CODE

DC to 18 GHz 15W Reflective SPDT GaN Switch**Handling Precautions**

Caution!
ESD-Sensitive Device
Handle Accordingly

Contact Information

For the latest specifications, additional product information, support, and sales.

Web: www.atekmidas.com

Tel: +90-212-483-71-67

Email: support@atekmidas.com

Notice

This document and its contents are property of ATEK MIDAS. ATEK MIDAS has carefully reviewed the product specification information herein, and it is believed to be accurate and reliable. However, no responsibility is assumed for inaccuracies or errors, and the information within may be changed at any time without prior notice. Use of this information and/or any of our products does not convey to the user any patent rights or licenses. ATEK MIDAS products are designed to be used only within the electrical and environmental limits published in their respective data sheets or custom quoted specifications. ATEK MIDAS does not authorize the use of any of its products beyond the current published data sheet limits. Such use beyond the currently published electrical and/or environmental data sheet limits voids all ATEK MIDAS warranties. ATEK MIDAS reserves the right to change component circuitry, package material, assembly/test/inspect processes, specifications or other information at any time without prior notice. ATEK MIDAS shall have no responsibility for the customer's products, customer applications, and actions of the customer related to this product.

Revisions

Revision No	Revision Date	Revision Reason	Section / Page No
0.1	27.04.2026	Initial Release	
0.2	05.06.2026	Product Release	