

5 to 22 GHz MMIC Driver Amplifier, Die

Product Description

The ATEK564 is a 5 to 22 GHz wideband GaAs pHEMT MMIC driver amplifier designed for radar, SATCOM, SDR, and Electronic Warfare transceivers. Operating from a +5V supply, it delivers 22-26 dB gain, +21 dBm P1dB, and an OIP3 exceeding +30 dBm.

For low-power applications, it can operate at +3V for increased gain at reduced output levels. Supplied as a bare die, the device minimizes external components by integrating 50-ohm matched RF ports, internal DC blocks, and a self-bias configuration that requires only two external decoupling capacitors

The ATEK564 is supplied as a bare MMIC die and has outstanding drive/linearity for a wide range of radar, SATCOM, SDR, test instrument, & EW/ECM transceiver applications. MMICs are available from stock.

Product Features

- Frequency Range: 5 to 22 GHz
- Gain: 22 to 26 dB
- P1dB: +22 dBm
- OIP3: +30 dBm
- Single Supply, +3V to +5V
- VD= +5V @ 123 mA

Applications

- Wideband Receivers, SDRs
- Microwave Radio
- Test and Measurement
- EW / ECM / C-UAS
- Military and Commercial Radar

Functional Block Diagram

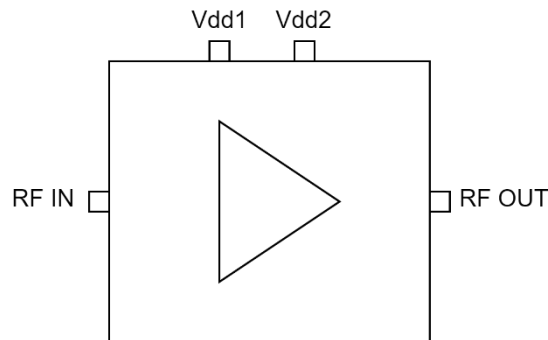

5 to 22 GHz MMIC Driver Amplifier, Die

Electrical Specifications

Conditions unless otherwise specified: $V_{DD1} = V_{DD2} = 5\text{ V}$, $I_{DQ} = 123\text{ mA}$, Typical, $T = 25\text{ C}$, CW.

Parameter		Min	Typ	Max	Units
Operational Frequency Range		4		22	GHz
Gain at 5V	5 GHz		22.4		dB
	8 GHz		22		
	12 GHz		22.7		
	18 GHz		24.2		
	22 GHz		20.7		
Gain at 3V	5 GHz		22.8		dB
	8 GHz		23.7		
	12 GHz		24.7		
	18 GHz		25.8		
	22 GHz		20.8		
Isolation at 5V	5 GHz		67		dB
	8 GHz		59		
	12 GHz		56		
	18 GHz		52		
	22 GHz		66		
Input Return Loss			-13		dB
Output Return Loss			-15		dB
Output IP3			30.5		dBm
Output P1dB at 5V			21.5		dBm
Output P1dB at 3V			17		dBm
Psat			22.5		dBm
Noise Figure			6		dB
DC Supply Voltage ($V_{DD1}=V_{DD2}$)			3 5	6.5	V
DC Supply Current			110 123		mA
Operating Temperature		-40		85	°C

5 to 22 GHz MMIC Driver Amplifier, Die

Typical Performance Plots

Conditions unless otherwise specified: $V_{DD1} = V_{DD2} = 5\text{ V}$, Typical, $T = 25\text{ C}$, CW.

Gain

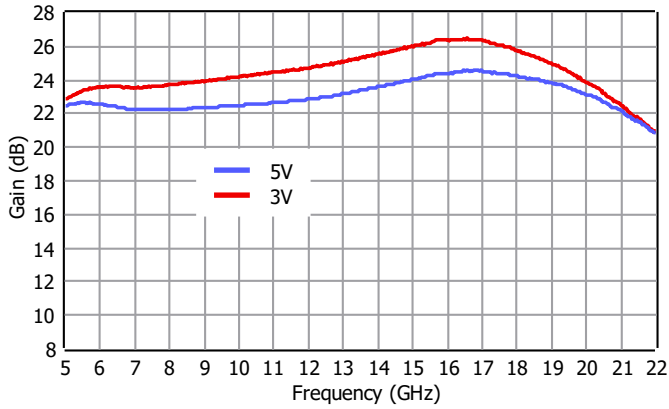

Gain Wideband

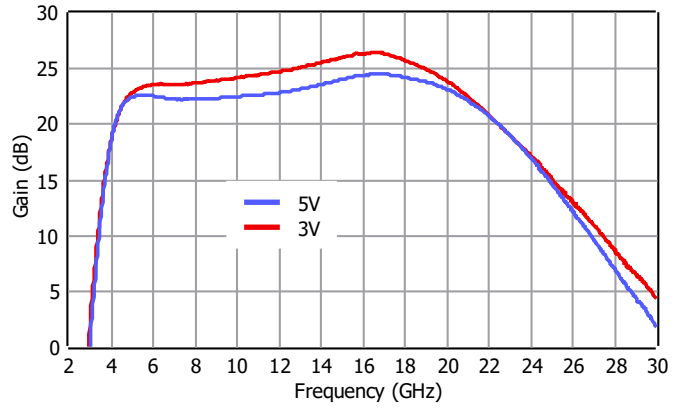

Input Return Loss

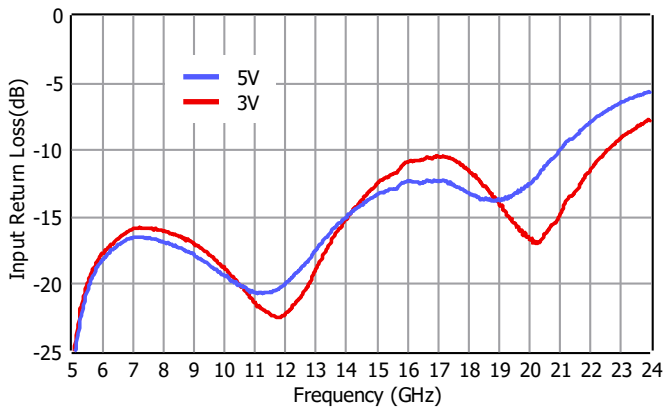

Output Return Loss

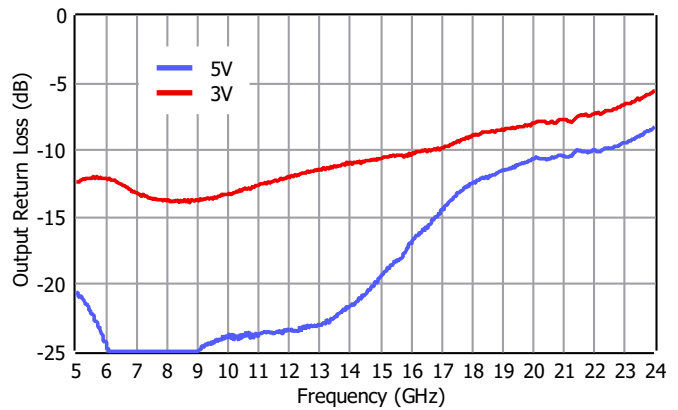

Isolation

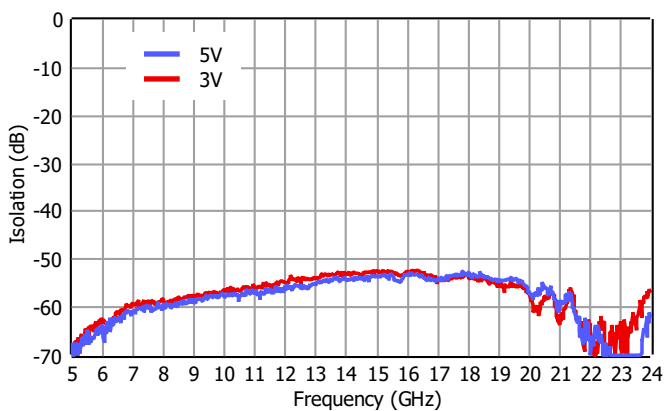

Noise Figure

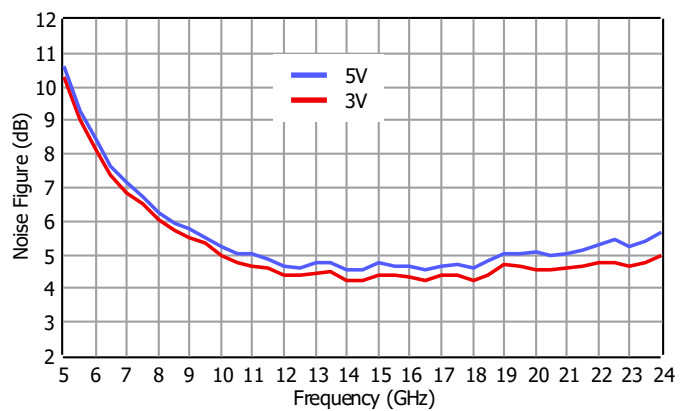

5 to 22 GHz MMIC Driver Amplifier, Die

Typical Performance Plots

Conditions unless otherwise specified: $V_{DD1} = V_{DD2} = +5\text{ V}$ Typical, $T = 25\text{ C}$, CW.

P1dB

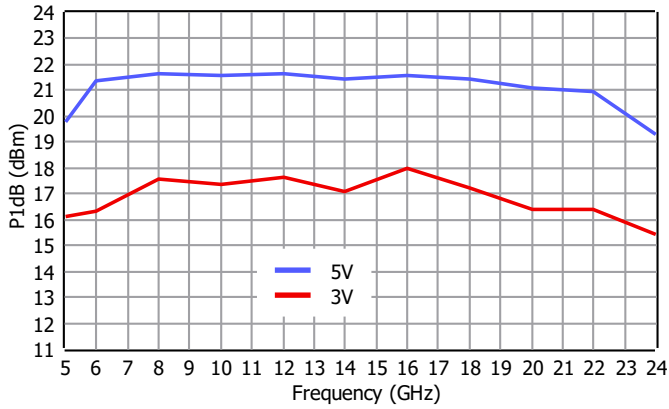

Current vs Output Power, Frequency

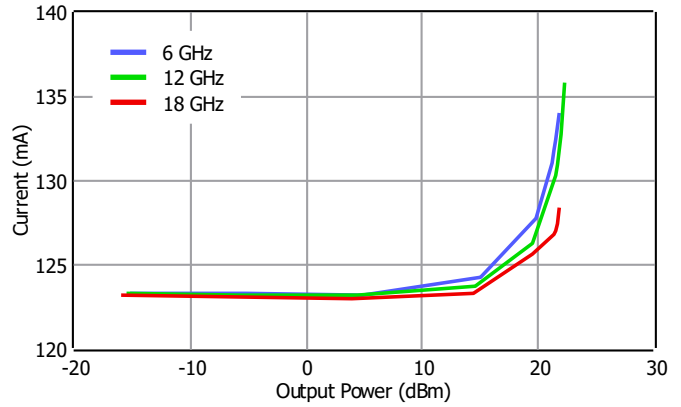

IP3

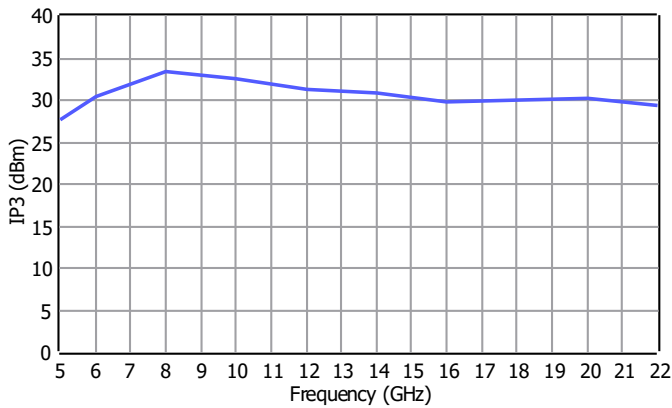

5 to 22 GHz MMIC Driver Amplifier, Die

Pad Description and Mechanical Dimensions

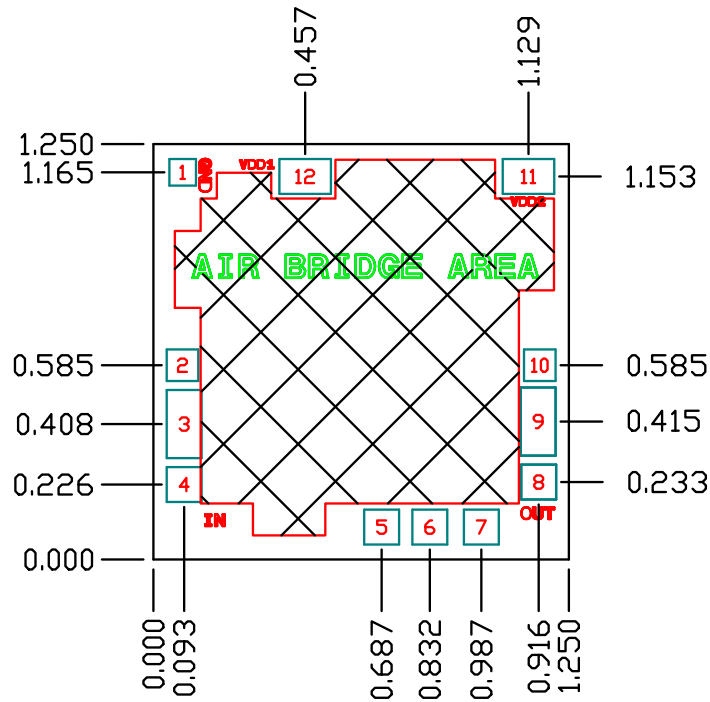

Units: millimeters
 Thickness: 0.10
 Die x, y size tolerance: ± 0.05
 Backside of die is ground

Pad Number	Pad Name	Pad Size (mm)	Description
3	RFIN	0.105x0.205	RF input pad. AC coupled.
9	RFOUT	0.105x0.205	RF output pad. AC coupled.
12	VDD1	0.155x0.105	Vdd bias pad.
11	VDD2	0.155x0.105	Vdd bias pad.
5, 6, 7	DNC	0.105x0.105	These pads are used for internal purposes. They should be left open/floating.
1	GND	0.080x0.080	Ground.
2, 10	GND	0.095x0.095	Ground.
4, 8	GND	0.105x0.105	Ground.
	Die Bottom		Ground.

5 to 22 GHz MMIC Driver Amplifier, Die

Applications Information

Signal entering from RF IN goes to RF OUT with an amplification.
A typical application schematic to operate the amplifier is given below.

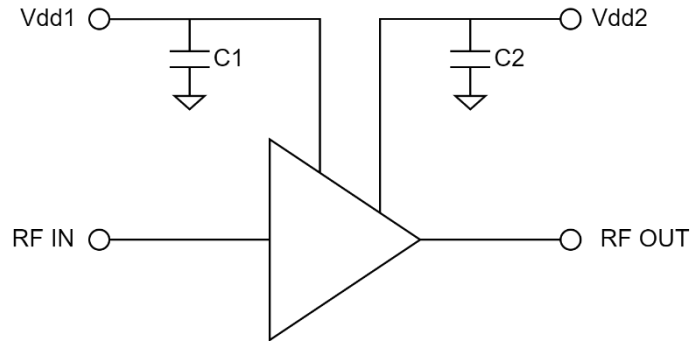

C1 and C2 are used to filter out the ripples and unwanted signals coming from the +Vdd supply. Using additional capacitors in parallel to C1 and C2 will improve this filtering. If this filtering is of no concern, then the amplifier can be operated without C1 and C2.

5 to 22 GHz MMIC Driver Amplifier, Die

Absolute Maximum Ratings

Parameter	Value/Range
Supply Voltage (Vdd)	+6.5 V
RF Input Power (Vdd=+5.0V)	+10 dBm
Channel Temperature	+175 °C
Continuous P _{diss} (T=85°C) (derate 13mW/°C above 85°C)	2.4W
Thermal Resistance (channel to die bottom)	36.8°C/W
Storage Temperature	-55 to +125 °C
Operating Temperature	-40 to +85 °C

Operation of this device outside the parameter ranges given above may cause damage. These conditions should not be applied simultaneously.

5 to 22 GHz MMIC Driver Amplifier, Die

Handling Precautions



Caution!
ESD-Sensitive Device
Handle Accordingly

Contact Information

For the latest specifications, additional product information, support, and sales.

Web: www.atekmidas.com

Tel: +90-212-483-71-67

Email: support@atekmidas.com

Notice

This document and its contents are property of ATEK MIDAS. ATEK MIDAS has carefully reviewed the product specification information herein, and it is believed to be accurate and reliable. However, no responsibility is assumed for inaccuracies or errors, and the information within may be changed at any time without prior notice. Use of this information and/or any of our products does not convey to the user any patent rights or licenses. ATEK MIDAS products are designed to be used only within the electrical and environmental limits published in their respective data sheets or custom quoted specifications. ATEK MIDAS does not authorize the use of any of its products beyond the current published data sheet limits. Such use beyond the currently published electrical and/or environmental data sheet limits voids all ATEK MIDAS warranties. ATEK MIDAS reserves the right to change component circuitry, package material, assembly/test/inspect processes, specifications or other information at any time without prior notice. ATEK MIDAS shall have no responsibility for the customer's products, customer applications, and actions of the customer related to this product.

Revisions

Revision No	Revision Date	Revision Reason	Section / Page No
1.0	27.03.2024	Initial Release	
1.1	20.01.2026	Pad Description and Mechanical Dimensions Updated	
1.2	05.02.2026	Plots Added	
1.3	17.02.2026	Format and Content Fixed	
1.4	14.05.2026	Format and Content Fixed	
1.5	05.06.2026	Product Release, Format & Content Fixed	