

Linear Piezomotor **LBS004 Series**

Piezo Motion's novel series of linear piezoelectric motors represent a quantum leap in design construction of compact, high-precision, performance linear motor technologies. This new range of linear motors combines superior nanometer precision and ultrafast response at a very economical cost.



Performance and Benefits of LBS004 Series Linear Motors

IMPROVED RESOLUTION

With a control step size of just 0.05 μm at full thrust or holding force, these linear motors offer 20,000 steps per mm of control.

FASTER REACTION TIME

Within 20 to 30 μs the piezo motor has made its first step, and motion has commenced compared to a stepper motor with a typical 5 ms to start motion.

HIGH-FORCE DENSITY

For their size and weight, these motors offer superior force density, particularly when compared with stepper and lead screw solutions.

ENERGY AND COST SAVINGS

The piezo motor consumes zero power at holding force and very low power at slow speed (0.06 W at 1 mm/s), yielding the possibility of very efficient overall duty.

SPECIAL PROPERTIES

Piezo Motion motors are immune to EMI and RF interference and have no emissions, making them ideal for a range of sensitive applications. For specialized applications (including MRI) please contact our technical team.

ECONOMICAL DESIGN

The innovative design and patent-protected technology packaged in stable reinforced thermoplastic makes this high-performing automation affordable for OEM equipment designers.

LIGHTWEIGHT

Our piezo motor contains no copper windings, iron laminations, or permanent magnets and is significantly more powerful by weight than EM solutions. This makes them ideally suited to weight-critical applications.

UNIQUE PROPERTIES

- Lightweight
- Low voltage
- 20,000 steps per mm of control
- Superior precision and resolution
- 9 mm travel range
- Six orders of magnitude speed dynamic range
- Silent operation in continuous mode
- Ultra-Fast response time with superior start-stop characteristics
- High force for size
- Energy efficient, zero power consumption in hold mode
- Stepping and Continuous mode of operation

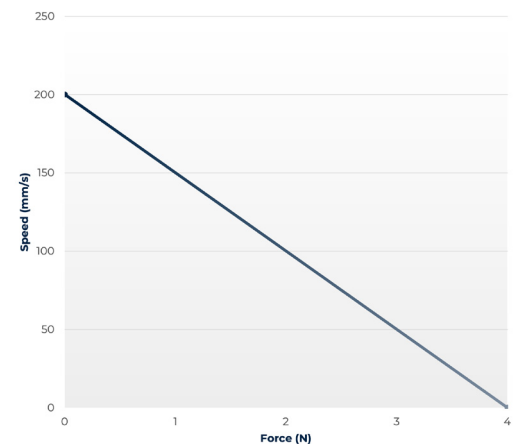

Speed-Force Curve for LBS Series Linear Motor

LBS004 Series

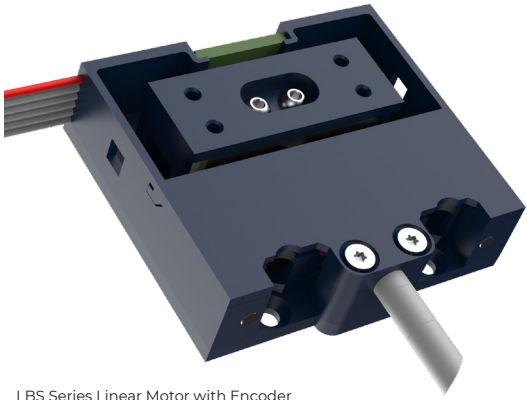

LBS Series Linear Motor with Encoder

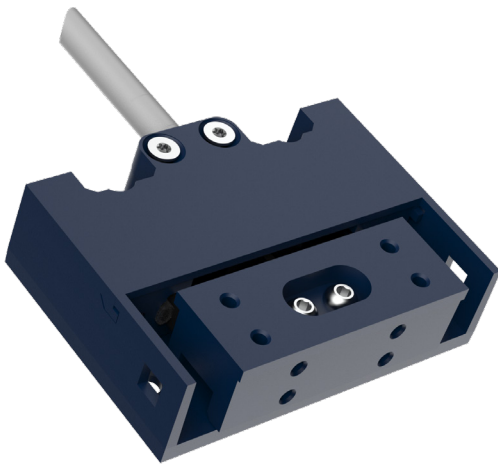

LBS Series Linear Standard Motor

MOTOR SPECIFICATIONS

	Standard	Encoder
Driver Board P/N	EDB60V012BB	EDB60V012BB
Power Supply Voltage	12 V	12 V
Push/Pull Force	≥ 4.0 N	≥ 4.0 N
Self-Braking Force	≥ 4.0 N	≥ 4.0 N
Motor Response Time	$\approx 30\mu\text{s}$	$\approx 30\mu\text{s}$
Max Speed	200 mm/s	140 mm/s
Travel Range	9.0 mm	9.0 mm
Minimum Linear Step	$< 0.04 \mu\text{m}$	$< 0.04 \mu\text{m}$
Encoder Resolution (after quadrature)	N/A	$2.66 \mu\text{m}$
Minimum Controlled Linear Step	N/A	$2.66 \mu\text{m}$
Uni-directional Repeatability	N/A	$2.66 \mu\text{m}$
Linear Backlash at Change of Direction	$\leq 0.1 \mu\text{m}$	$\leq 0.1 \mu\text{m}$
Elastic stiffness	$\approx 220 \text{ mN}/\mu\text{m}$	$\approx 220 \text{ mN}/\mu\text{m}$
Linear Hysteresis	$\leq 2.0 \mu\text{m}$	$\leq 2.0 \mu\text{m}$
Pitch	$\leq 450 \mu\text{Rad}$	$\leq 450 \mu\text{Rad}$
Maximum Moment Mx	0.07 Nm	0.07 Nm
Roll	$\leq 225 \mu\text{Rad}$	$\leq 225 \mu\text{Rad}$
Maximum Moment My	0.12 Nm	0.12 Nm
Yaw	$\leq 450 \mu\text{Rad}$	$\leq 450 \mu\text{Rad}$
Maximum Moment Mz	0.9 Nm	0.9 Nm
Vertical Runout	$3.0 \mu\text{m}$	$3.0 \mu\text{m}$
Horizontal Runout	$6.0 \mu\text{m}$	$6.0 \mu\text{m}$
Frequency Response	4 kHz	4 kHz
Operating Temperature	-20 to 80 °C	-20 to 80 °C
Maximum Load (at listed specification)	400 g	400 g
Max Current over velocity range	350 mA	350 mA
Motor Weight	22 g	25 g
Motor Dimensions	40x31x11 mm	40x31x11 mm
Driver PCB Dimensions	40x63x25 mm	40x63x25 mm
Driver PCB Weight	25 g	25 g

Principle of operation

Piezo Motion's rotary piezo motors work on a patented principle of excitation of ultrasonic standing waves within a piezoelectric resonator. The resulting superposition of two orthogonal ultrasonic waves causes elliptical movement of the resonator tip which drives the rotor (for more details visit piezomotion.com). Piezo Motion's electronic driver's have been designed to provide an economical user-control interface. Each driver PCB is preprogrammed for the specific motor model and is software configurable to provide optimization of drive signals and integrated controls. Closed-loop control of the motor is achieved via an encoder mounted on the motor.

LBS004 Series dimensional drawings

STANDARD MODEL

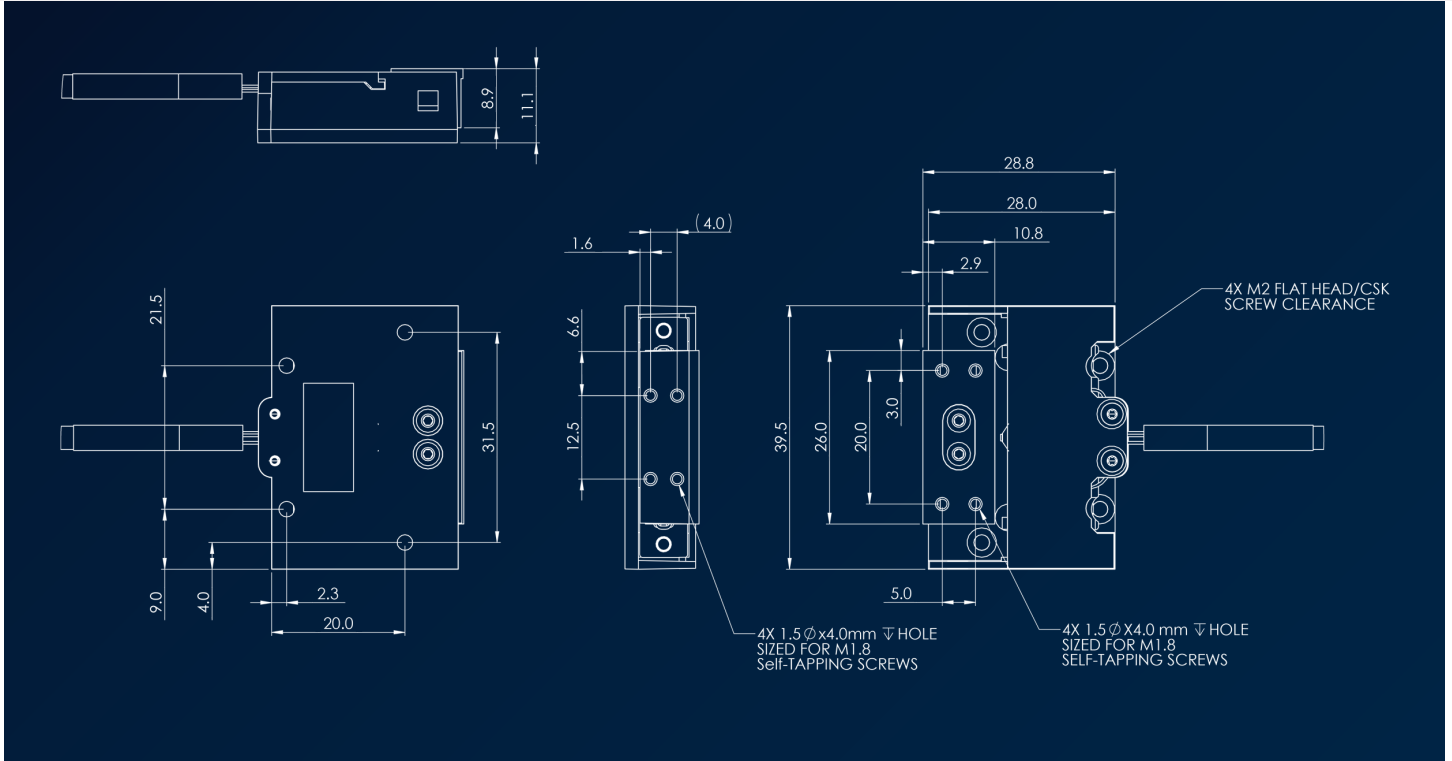

ENCODER MODEL

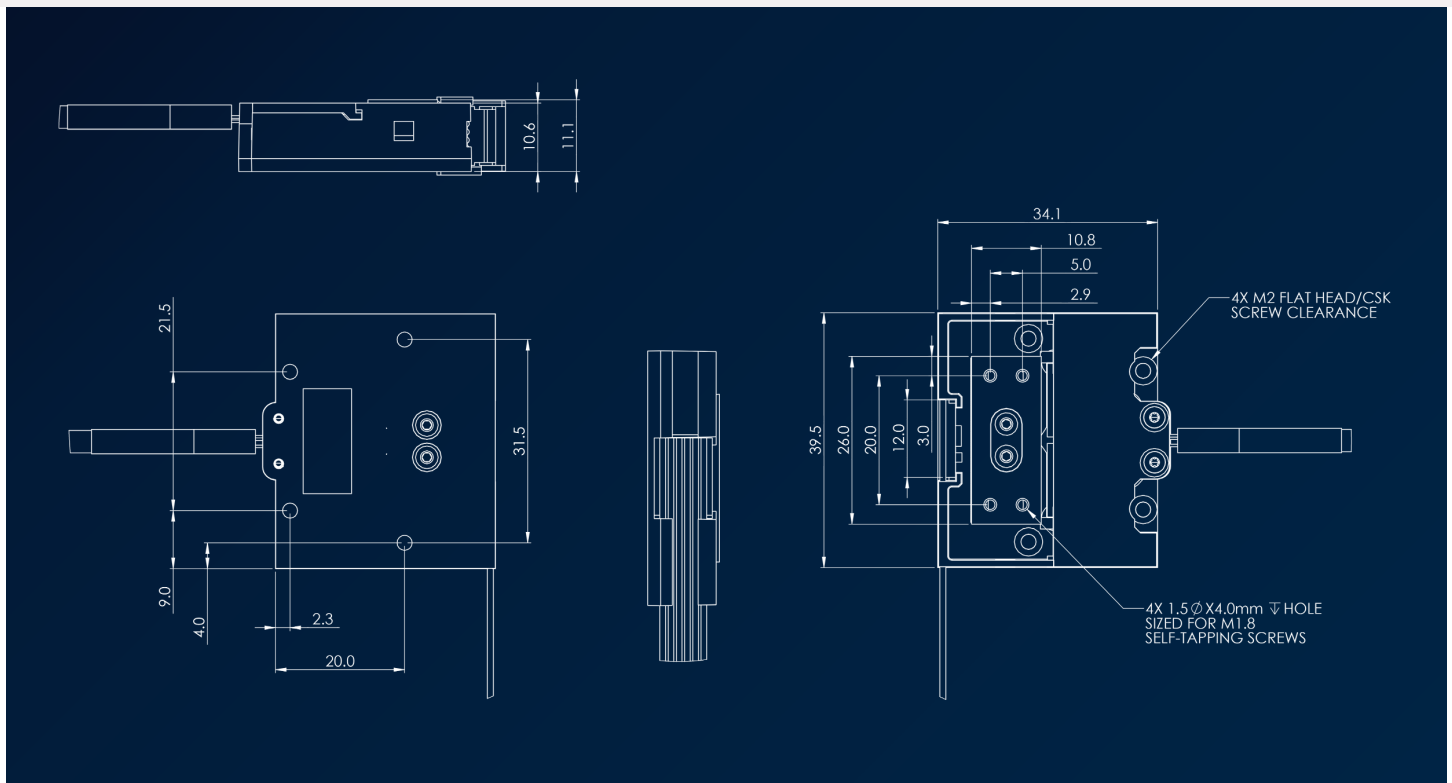

Motor **control**

The control of the LBS Linear Motor is straightforward, each motor requires a driver board. This board will convert desired motion input instructions to the necessary electrical processes using specific frequency and amplitude values. This creates excitation of the piezo resonator and makes the motor perform the desired motion. For motors with an encoder, a daughter board is attached to the driver board to provide both closed-loop feedback as well as serial interfacing for external programming capabilities via Piezo Motion's software or serial commands.

OPEN LOOP

The driver board can be controlled using an external signal source PWM (Pulse Width Modulation) mode. Control signals are applied to the External Signal Connector to generate the desired rotation and speed. Control of speed using PWM is implemented by varying the pulse duration and repetition rate of input signals onto the two directional control pins. Size of step is determined by the pulse duration, and speed is determined by pulse rate. The minimum pulse duration is approximately 30 μ s.

CLOSED-LOOP

Pre-programmed motion control algorithms enable the implementation of several commands for specific motion control. The key commands are for defining the speed and the movement to a defined position. These commands are resident within a library which can be accessed using either Piezo Motion's control software or via the serial port using TTL serial commands. Motor Control can also be implemented with Python commands using Piezo Motion's Motor API.

Electronic PCB Driver for **LBS004 Series Piezomotors**

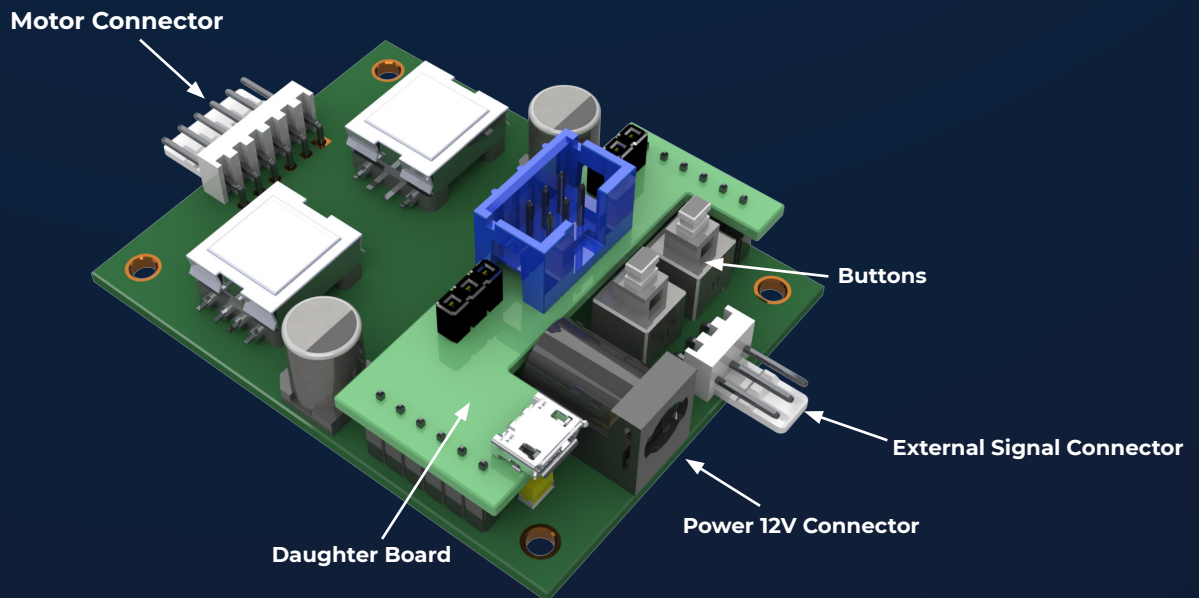

ELECTRONIC DRIVERS

EDB60V012BB Electronic PCB Driver - Open Loop board only

Control architecture & options

Piezo Motion motors are available as a basic motor or with a fitted encoder. Piezo Motion electronic drivers are available as open-loop or closed-loop drivers which are fitted with an encoder daughter board. Motors can be simply controlled in open-loop mode with several options for achieving closed-loop motion control. To learn more, visit piezomotion.com/products/motors/ or scan the QR code below.

	Open-Loop Driver	Closed-Loop Driver with Encoder board
Base Motor	Open-Loop Control or third party controller command motor with PWM control and close control loop with external sensor	
Motor with Encoder	Open-Loop Control or third party controller command motor with PWM control and close control loop Piezo Motion Encoder output	Motor Control with: Piezo Motion Control Software on Windows OS device or Piezo Motion Python API on third party controller or TTL Serial Port Commands

Evaluation Kits

Full range of evaluation kits available. Each kit includes motor, driver board pcb, cables, 5 VDC or 7.5 VDC power adapter & user manual. Encoder kit version also includes factory-fitted magnetic encoder with cable and connector.

ORDERING INFORMATION

Motor Type	LBS004009LAC30-K	LBS004009LAC30-EK
Description	Evaluation kit for LBS series linear motor with steel linear slide bearing and fixed stroke of 9 mm. The motor has a force ≥ 4 N force. It has a 30 cm cable terminated with a molex connector. Evaluation kit includes electronic driver board, 120/220 V to 12 VDC power adapter, cables and manual.	Evaluation kit closed-loop for LBS series linear motor with steel linear slide bearing and fixed stroke of 9 mm. The motor has a force ≥ 4 N force and is fitted with an optical encoder (2.66 μ m). It has a 30 cm cable terminated with a molex connector. This evaluation kit includes electronic driver board, motion control software, 120/220 V to 12 VDC power adapter, cables and manual.
Linear Force	≥ 4.0 N	≥ 4.0 N
Encoder Type	N/A	Optical
Linear Stroke	9 mm	9 mm
Minimum Linear Step	< 0.04 μ m	< 0.04 μ m

For OEM and custom inquires, contact us at info@piezomotion.com or scan the QR code below.

About Piezo Motion

Piezo Motion is a leader in piezo motor technology with multi-million dollar investments in research and development of affordable piezoelectric motors to meet, and exceed, the needs of today's global markets.

The company is committed to developing innovative piezoelectric technology and motion products that enhance their functionality in a multitude of applications.

Piezo Motion partners with startups, OEMs, research institutions, and industrial companies worldwide; empowering the visionaries behind their products.

**SCAN TO
LEARN MORE
& BUY ONLINE**

