



Ultra-Compact Piezoelectric XYZ Stage for Precision Motion

Introducing the LRMO-XYZ the world's smallest lightweight piezoelectric XYZ platform designed for superior precision and expanded functionality for advanced applications.

Key Advantages of LRMO-XYZ System

- Compact light weight design (just 1" x 1" x 1.8")
- Superior Resolution: > 40 nm = 25,000 steps per mm of linear travel with 9.0 mm of Travel per Axis
- Max Speed: ≈ 0.15 m/s
- Fast Response Time: ≈ 30 μ s
- Low Voltage Design: 5 V DC
- Zero power consumption in hold mode
- Optical encoder (optional): 2.66 μ m close loop resolution

Design Principle

The LRMO-XYZ system integrates three precision miniature linear piezomotors each with 9.0 mm of travel (PMC Model# LRMO) into a compact XYZ stage, providing precise multi-axis motion in an ultra-small footprint. It is ideal for space-limited applications where silent operation, zero backlash, and sub-micron resolution are required.

The LRMO-XYZ offers reliable, high-precision XYZ motion control for delicate applications where traditional XYZ designs are too bulky, heavy or generate electromagnetic interference, making it ideal for next-generation motion solutions in optics, life sciences, and precision instrumentation.

Electronic Driver Supports UART & I2C

The electronic driver is designed to offer an economical interface for user control. Motion of the motor is achieved via PWM (Pulse Width Modulation) control signals. The driver PCB also supports UART and I2C interfaces. The driver PCB is pre-programmed for software configurability, optimizing drive signals and integrating controls. Motor operation can be finely regulated through closed-loop control using an optional encoder factory-installed on the actuator.

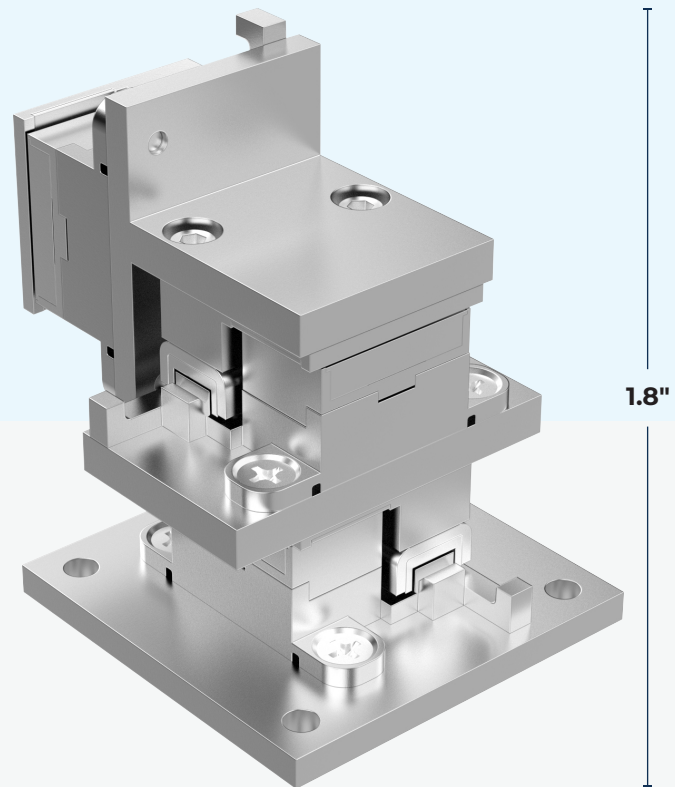

Typical Applications

PHOTONICS AND OPTICS

- Laser beam alignment and steering
- Optical switching and MEMS device positioning
- Fiber optic alignment for telecom or laboratory systems

MICROSCOPY AND LIFE SCIENCES

- Automated sample positioning and scanning
- Focus adjustment for imaging systems
- Compact stages for fluorescence or confocal microscopy

TEST AND MEASUREMENT

- Sensor and probe positioning in lab automation
- Fine calibration of microelectronic components
- Alignment in spectrometry or interferometry setups

PORTABLE AND EMBEDDED DEVICES

- Field-deployable optical or analytical instruments
- Medical devices requiring ultra-compact motion systems

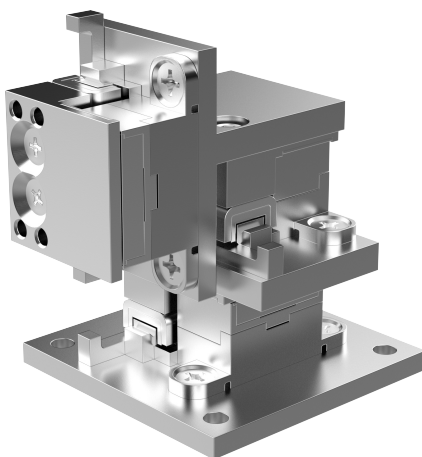
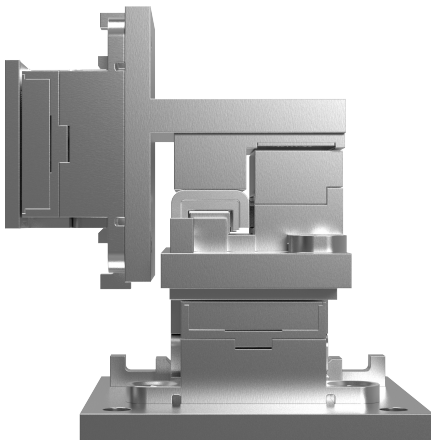
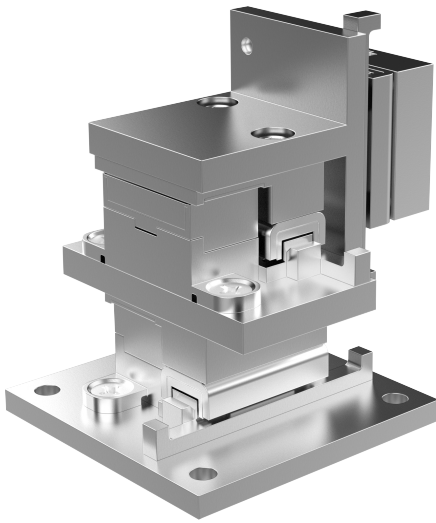

LRMO-XYZ System Specifications

Part No. (Non-Encoder Version)	LRMO-XYZ
Power Supply Voltage	5.0 V DC
Push/Pull Force	≥0.2 N
Self-Braking Force	≥0.25 N
Motor Response Time	≈30 μs
Travel Range	9.0 mm
Max Speed (continuous mode)	≈150 mm/s
Minimum Linear Step	<0.04 μm (<40 nm)
Linear Backlash at Change of Direction	<0.1 μm
Elastic Stiffness	≈200 mN/μm
Linear Hysteresis	<2.0 μm
Pitch	<1 mrad
Maximum Moment Mx	0.07 Nm
Roll	<0.5 mrad
Maximum Moment My	0.12 Nm
Yaw	<1 mrad
Maximum Moment Mz	0.9 Nm
Vertical Runout	3.0 μm
Horizontal Runout	6.0 μm
Frequency Response	4 kHz
Operating Temperature	-20 °C to 80 °C
Maximum Load (at listed specification)	20 g
Maximum Tolerable Load	4.2 kgf
Max Current (continuous mode)	300 mA
Max. Current at the velocity 10mm/s (PWM mode)	30-40 mA
System Weight	<50 g
Motor Dimensions	1" X 1" X 1.8"
Driver PCB Dimensions	31x28x9.6 mm
Driver PCB Weight	6.8 g

Ordering Information

Part Number	Description
LRMO-XYX-SYS	Includes: 3-Axis positioning system (non-encoder version), 3 X Driver PCB's, I2C adapter board, Raspberry Pi Controller interface with LCD Display and Python API, 120/240 VAC to 5 VDC power adapter and cables.
LRMO-XYZ-E-SYS	Includes: 3-Axis positioning system (with optical encoders), 3 X Driver PCB's, I2C adapter board, Raspberry Pi Controller interface with LCD Display and Python API close-loop software, 120/240 VAC to 5 VDC power adapter and cables.

LRMO-XYZ Systems dimensional drawings

STANDARD MODEL (Dimensions in mm)

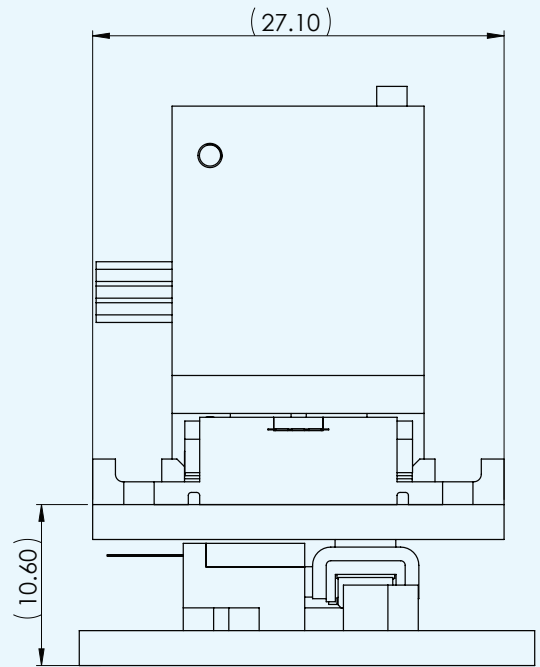
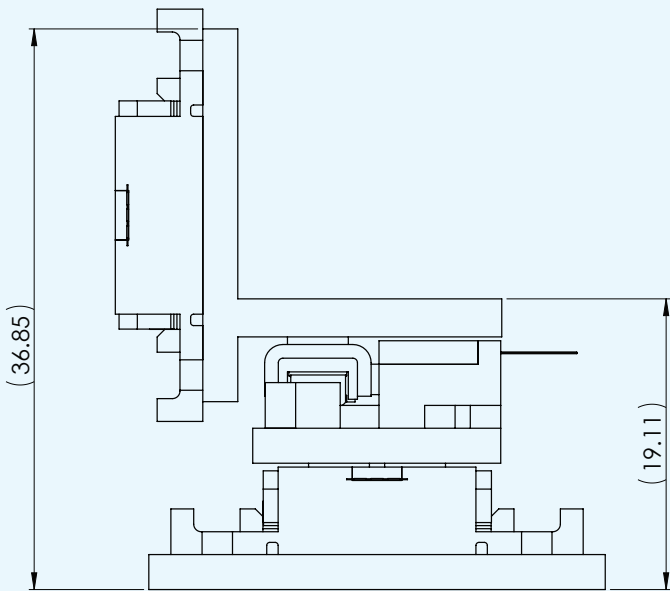
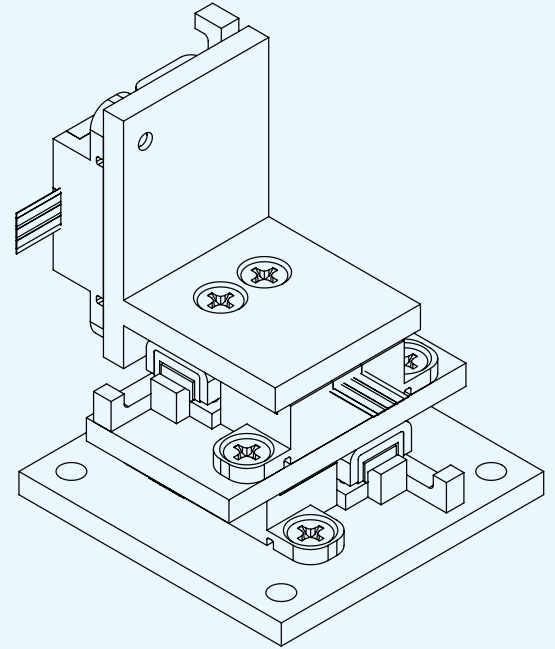
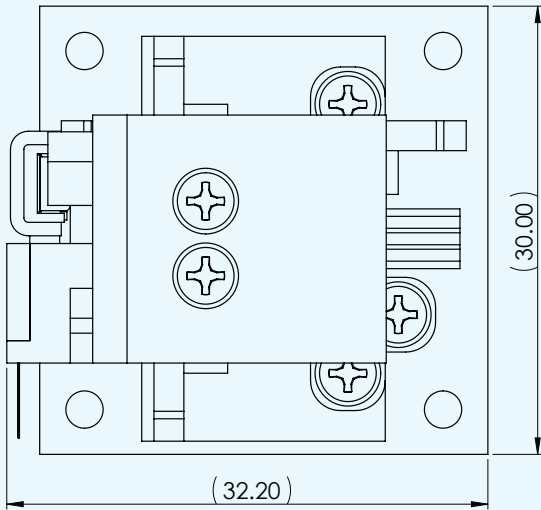



LRMO-XYZ Systems dimensional drawings

ENCODER MODEL (Dimensions in mm)

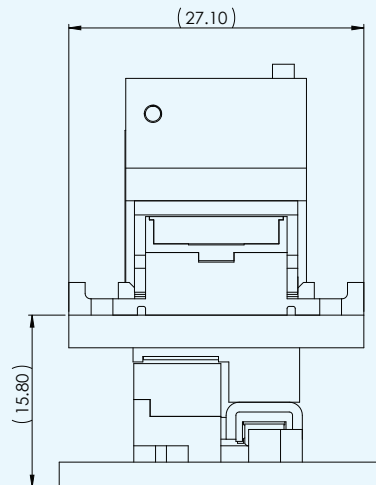
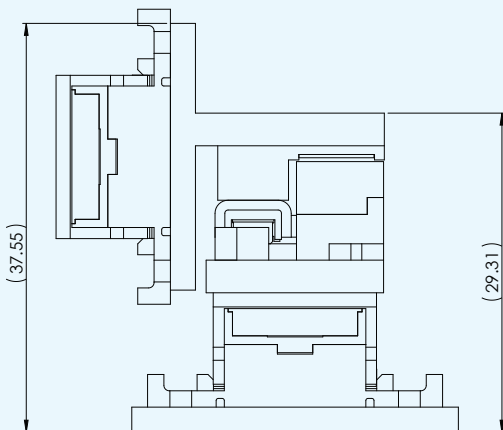
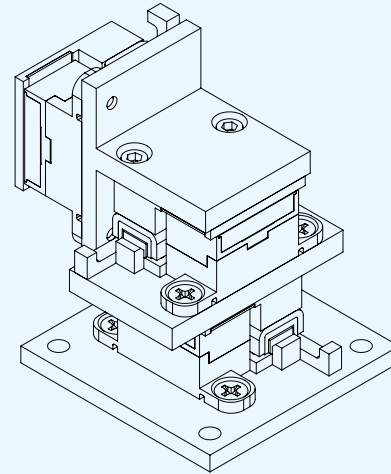
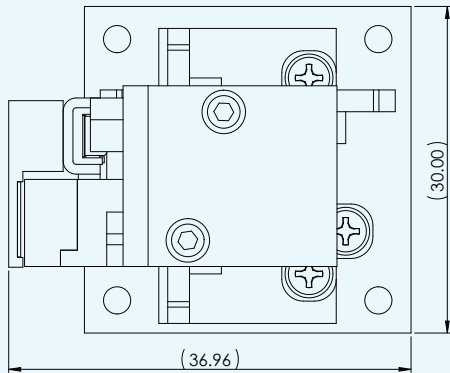

About Piezo Motor Company LLC

Founded in 2024, Piezo Motor Company is at the forefront of innovation in the design and manufacturing of piezoelectric motors. Headquartered in the USA, we have a global reach through a network of international distributors, delivering cutting-edge technology to clients worldwide.

Our team comprises highly skilled experts with extensive experience in piezoelectric motor and actuator design and physics. We are passionate about harnessing the unique properties of piezoelectric materials to create motors that offer unmatched precision, efficiency, and reliability. Our solutions are tailored to meet the diverse needs of industries ranging from medical devices to aerospace and robotics.

We pride ourselves on our commitment to excellence and innovation, continuously pushing the boundaries of what piezoelectric technology can achieve. Our dedication to research and development ensures that we remain leaders in this dynamic field, providing our clients with the most advanced and effective solutions available. Join us on our journey as we revolutionize the world of motion control with piezoelectric technology.