

1200 Watts

- Configurable Power Supply
- Low Profile for 1U Applications
- Medical & ITE Approvals
- Power from 850 W at Low Line to 1200 W at High Line
- Output Voltages from 3V3 to 60 V
- Module Power up to 300 W
- Parallel Options for Increased Versatility
- PMBus Digital Interface
- Graphical User Interface (GUI)
- Optional Reverse Air Fans with No Load Derating
- 3 Year Warranty



Dimensions:

nanoflex:
N12: 4.20 x 11.50 x 1.67" (106.7 x 292.1 x 42.2 mm)

The N12 nanoflex configurable 1U power supply has been designed to maximize efficiency and minimize audible fan noise to combat the traditional challenges associated with low profile configurable products. The chassis can provide 850 W with universal input or 1200 W with high line (or line to line) with up to 4 outputs. These outputs are customer selected from a wide range of fixed or variable voltages between 3.3 V & 60 V DC. The N12 is suited to Industrial (IEC 62368) & Medical (IEC 60601) applications with earth leakage current below 300 μ A whilst returning excellent emission performance. This fully featured power supply can be controlled with both analogue and digital (I²C) commands, provides a full 10 W (5 V/2 A) standby rail and a range of connectivity options.

Models & Ratings

Max Power 90 to 180 VAC	Max Power 180 to 264 VAC	Standby	Capacity	Width	Code
850 W	1200 W	5 V/2 A	4 Slots	4.2" (106.7 mm)	N12

Notes

For mechanical details, refer to pages 8 & 9.

Modules

Voltage Range ^(1,2)	Preset Voltage	Maximum Current	Maximum Power	Slots	Code	
3.3-5.5 V	3V3	40.0 A	132 W	1	A	
Blank Plate						
3.3-5.5 V	5 V	40.0 A	200 W	1	C	
	5V2	38.5 A	200 W	1	D	
	5V5	36.4 A	200 W	1	E	
	8 V	20.8 A	166 W	1	F	
8-15 V	10 V	20.8 A	208 W	1	G	
	12 V	20.8 A	250 W	1	H	
	14 V	17.9 A	250 W	1	I	
	15 V	16.7 A	250 W	1	J	
	18-30 V	18 V	12.5 A	225 W	1	K
20 V		12.5 A	250 W	1	L	
24 V		12.5 A	300 W	1	M	
28 V		10.7 A	300 W	1	N	
30 V		10.0 A	300 W	1	O	
33-60 V		33 V	9.09 A	300 W	1	P
		36 V	8.33 A	300 W	1	Q
		48 V	6.25 A	300 W	1	R
		54 V	5.56 A	300 W	1	S
		60 V	5.0 A	300 W	1	T

Notes

For configurations, refer to page 2.

1. Module output voltage can be adjusted within given range using digital serial interface, external 1.5 to 5.0 V signal or inbuilt potentiometer.
2. The table shows the standard preset voltages available. For factory setting of other voltages a model order code will be assigned at the time of order.

Configuration Examples

Front End Designation			
Model	115 V	230 V	Slots
N12	850 W	1200 W	4

Module Designation					
Voltage VDC	Current	Power	Slots	Code	
3V3	40.00 A	132 W	1	A	
Blank Plate			1	B	
5V	40.00 A	200 W	1	C	
5V2	38.50 A	200 W	1	D	
5V5	36.40 A	200 W	1	E	
8V	20.80 A	166 W	1	F	
10V	20.80 A	208 W	1	G	
12V	20.80 A	250 W	1	H	
14V	17.90 A	250 W	1	I	
15V	16.70 A	250 W	1	J	
18V	12.50 A	225 W	1	K	
20V	12.50 A	250 W	1	L	
24V	12.50 A	300 W	1	M	
28V	10.70 A	300 W	1	N	
30V	10.00 A	300 W	1	O	
33V	9.09 A	300 W	1	P	
36V	8.33 A	300 W	1	Q	
48V	6.25 A	300 W	1	R	
54V	5.56 A	300 W	1	S	
60V	5.00 A	300 W	1	T	

Parallel Option Codes	
Code	Description
00	No parallel required
12	Parallel module 1 & 2 from right
13	Parallel modules 1 to 3 from right
14	Parallel modules 1 to 4 from right
22	Parallel module 1 & 2, 3 & 4

Option Codes	
Code	Description
A00	No options
A01	Fan fail signal
A02	Reverse air flow
A03	Faston O/P connections
A04	IEC inlet

Combined Option Codes	
Code	Description
C01	A01-02
C02	A01 & 03
C03	A01 & 04
C04	A01-03
C05	A01-02 & 04
C06	A01-04
C07	A02-03
C08	A02 & 04
C09	A02-04
C10	A03-04
C11	A01 & A03 & A04

Code
12
13
14
22

Slot			
4	3	2	1

Modules are populated from the right, when unit is viewed from the DC module end. The modules are configured such that an output requiring the highest number of paralleled modules would go first, then the next highest and so on. Once this sequence is complete or if two outputs use paralleled modules then modules are configured lowest to highest voltage again from the right when the unit is viewed from the DC module end.

DC Module End

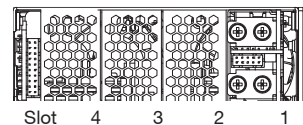

Examples

1. 5V at 80 A, 12V at 12 A with no options: N12-CCHB-12A00



2. 24V at 10 A, 48V at 18 A with optional IEC Inlet: N12-RRRM-13A04



Input

Characteristic	Minimum	Typical	Maximum	Units	Notes & Conditions
Input Voltage - Operating	80		264	VAC	Derate output from 850 W at 90 VAC to 765 W at 85 VAC and 680 W at 80 VAC
Input Voltage - Fault condition			300	VAC	For 5 s maximum, without derating or damage
Input Frequency	47		63	Hz	400Hz operation okay but not covered by safety approval
Power Factor		0.98			230 VAC 100% load EN61000-3-2 class A
Input Current - Full Load		9.0 / 6.3		A	115 / 230 VAC
Inrush Current			70	A	264 VAC cold start, 25 °C
No Load Input Power		40 10		W	90 VAC, 4 modules fitted With Global Inhibit
Earth Leakage Current			270	µA	264 VAC, 60 Hz
Input Protection	F12.5 A / 250 V internal fuse fitted in line and neutral				

Output

Characteristic	Minimum	Typical	Maximum	Units	Notes & Conditions
Output Voltage	3.3		60	VDC	See Modules table
Initial Set Accuracy			±1	%	
Output Voltage Adjustment					See Modules table. Via inbuilt potentiometer, 1.5 V to 5.0 V signal or digital control. See Analogue Signals section.
Minimum Load	0			A	No minimum load
Start Up Delay		2.4	3.5	s	At 90 VAC, full load room temp., max at -20 °C
Hold Up Time	16/10	18/12		ms	850/1200 W, 28 V and 30 V outputs have limited hold up and no AC fail warning
Line Regulation			0.5	%	
Load Regulation			1	%	
Transient Response		2		%	Recovery to within 1% in less than 500 µs for a 25% step load change
Over/Undershoot			5	%	At turn on and turn off
Ripple & Noise			1	% pk-pk	
Overvoltage Protection	115		140	%	Latching, recycle input to restart
Overload Protection	110		150	% I nom	
Short Circuit Protection					Hiccup (trip & restart), see fig. 2
Temperature Coefficient			0.05	%/°C	
Overtemperature Protection					Auto resetting
Remote Sense			0.25	V	Compensate for a maximum voltage drop for 0.25 V

Input Voltage Derating Curve

Figure 1

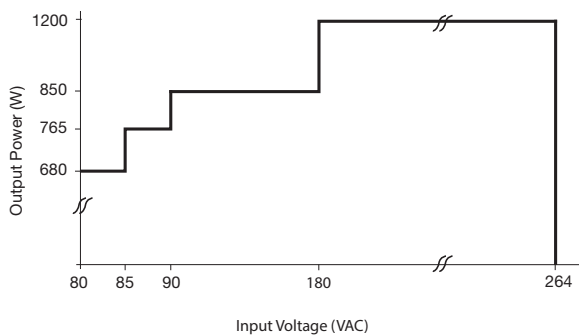

Output Overload Characteristic

Figure 2

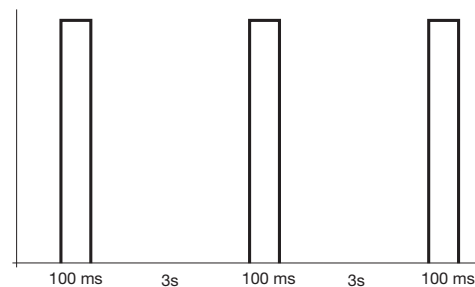

General

Characteristic	Minimum	Typical	Maximum	Units	Notes & Conditions
Efficiency		90		%	See fig. 3 & 4
Isolation: Input to Output Input to Ground Output to Ground	4000			VAC	2 x MOPP
	1500			VAC	1 x MOPP
	500			VDC	
Switching Frequency	63	65	70	kHz	For PFC converter
	110	125	135		For main converter
	230		250		For DC output module
Power Density		15		W/in ³	At high line
Mean Time Between Failure		690		kHrs	Telcordia SR-332, Issue 2, based on N12-CMHB-00-A00 configuration
Weight			2.6 (1.25)	lb (kg)	For chassis
			0.15 (0.07)		Each module

Typical Efficiency Vs Load

Figure 3 - N12-HHHH-14A00

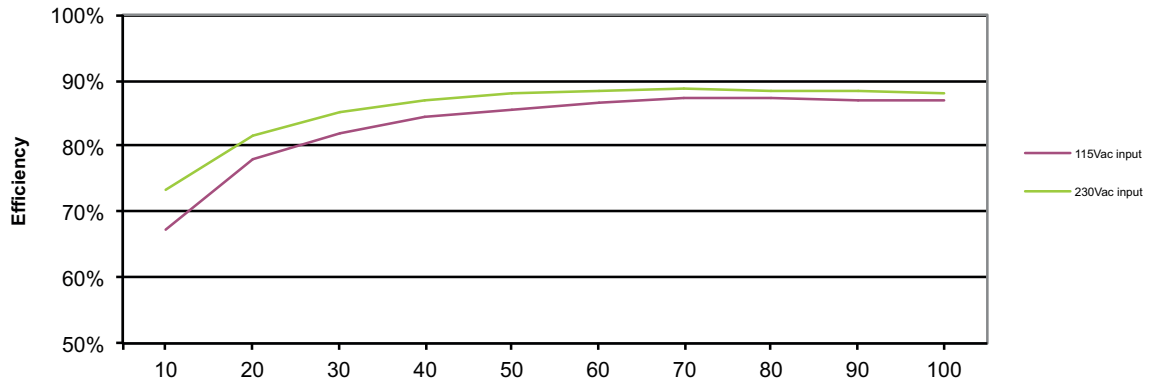
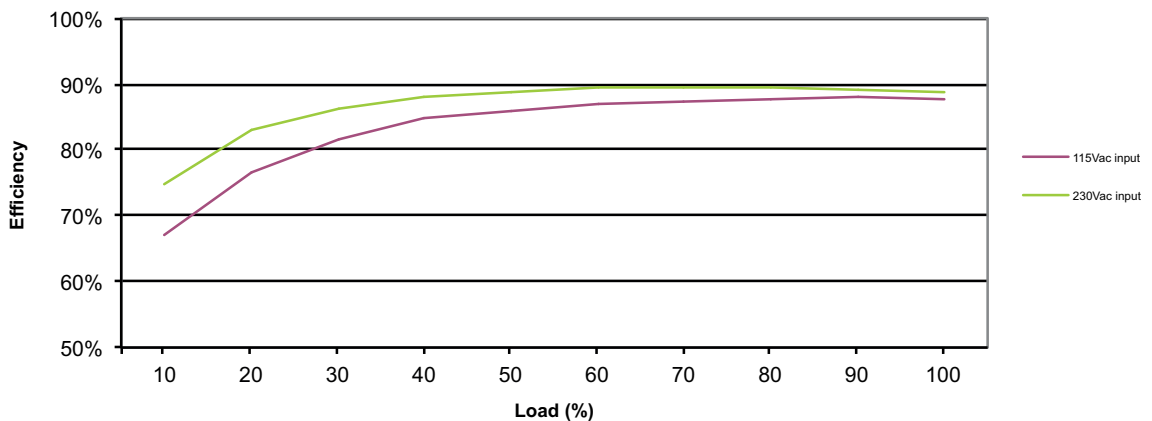

Figure 4 - N12-MMMM-14A00



EMC: Emissions

Phenomenon	Standard	Class	Notes & Conditions
Conducted	EN55011/32	B	
Radiated	EN55011/32	A	
Harmonic Current	EN61000-3-2	A	
Harmonic Fluctuations	EN61000-3-3	A	

EMC: Immunity

Phenomenon	Standard	Test Level	Criteria	Notes & Conditions
Low Voltage PSU EMC	EN61204-3	High Severity Level	As below	
Medical Device EMC	IEC60601-1-2	Ed 4.0:2014	As below	
ESD	EN61000-4-2	4	A	±8 kV contact, ±15 kV Air
Radiated	EN61000-4-3	3	A	
EFT	EN61000-4-4	3	A	
Surge	EN61000-4-5	Installation Class 3	A	
Conducted	EN61000-4-6	3	A	
Magnetic Fields	EN61000-4-8	4	A	
Dips and Interruptions	EN55024 (100 VAC)	Int >95% (0 VAC) 8.3 ms	A	
		Dip 30% (70 VAC) 416 ms	A	
		Int >95% (0 VAC) 4160 ms	B	
	EN55024 (240 VAC)	Int >95% (0 VAC) 10 ms	A	
		Dip 30% (168 VAC) 500 ms	A	
		Int >95% (0 VAC) 5000 ms	B	
	EN60601-1-2 (100 VAC)	Int 100% (0 VAC) 10 ms	A	
		Int 100% (0 VAC) 20 ms	B	
		Dip 60% (40 VAC) 100 ms	A	
		Dip 30% (70 VAC) 500 ms	A	
	EN60601-1-2 (240 VAC)	Int 100% (0 VAC) 5000 ms	B	
		Int 100% (0 VAC) 10 ms	A	
		Dip 60% (96 VAC) 100 ms	A	
		Int 100% (0 VAC) 20 ms	B	
		Dip 30% (168 VAC) 500 ms	A	
		Int 100% (0 VAC) 5000 ms	B	

Safety Approvals

Safety Agency	Safety Standard	Notes & Conditions
CB Report	IEC60950-1, IEC62368-1	Information Technology
	IEC60601-1	Medical
UL	UL62368-1	Information Technology
	ANSI/AAMI ES60601-1 +CSA C22.2 No.60601-1: 08	Medical
TUV	EN62368-1	Information Technology
	EN60601-1	Medical
CE	Meets all applicable directives	
UKCA	Meets all applicable legislation	
Equipment Protection Class	Class I	

Means of Protection		Category
Primary to Secondary	2 x MOPP (Means of Patient Protection)	IEC60601-1 Ed 3.1
Primary to Earth	1 x MOPP (Means of Patient Protection)	

Environmental

Characteristic	Minimum	Typical	Maximum	Units	Notes & Conditions
Operating Temperature	-40		+70	°C	With integral fan, derate from 100% load at 50 °C to 50% load at 70 °C, see derating curve
Storage Temperature	-40		+85	°C	
Humidity			95	%RH	Non condensing
Operating Altitude			3048	m	
Acoustic Fan Noise	54		62	Lw db(A)	115 VAC 850 W/230 VAC 1200 W
				Lw db(A)	Fan speed based on output load and ambient temperature
				Lw db(A)	
Shock	±3 x 30 g on each plane 30g = 11 ms (±0.5 ms) Half sine conforms to EN60068-2-27 and -2-47				
Vibration	Single axis 10 - 500 Hz at 2g sweep and endurance resonance in all 3 planes conforms to EN60068-2-6				

Thermal Derating Curve

Figure 5

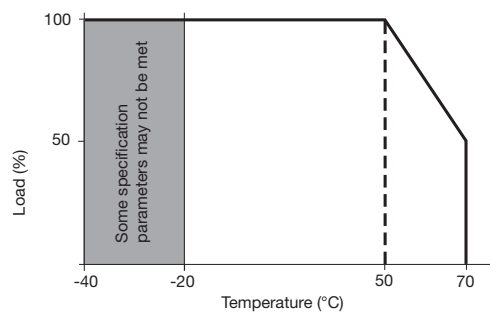

Application Notes: Modules

Modules: A, C, D & E

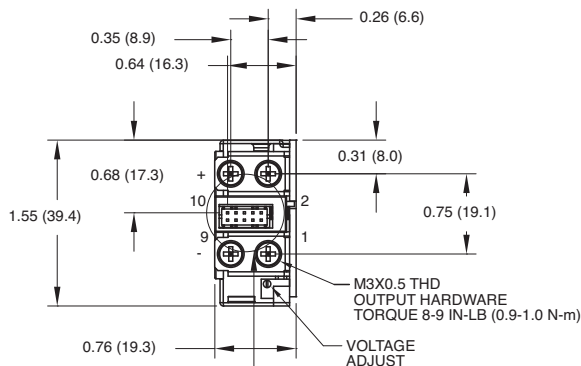

All other modules

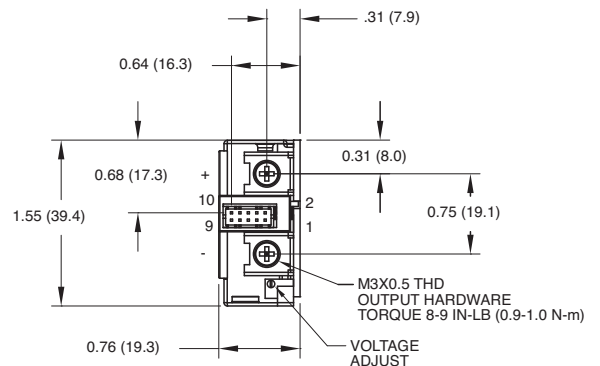

Output Module Signal Connector

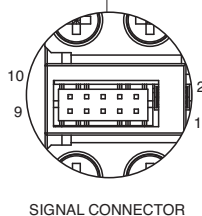

Signal Connector 10 Pos	
Pin	Function
1	Sense-
2	P_Sync
3	I_Share
4	I_Share
5	V_Prog
6	Sense+
7	DCOK_C
8	DCOK_E
9	INH
10	INH_RTN

Application Notes: Analogue Signals

Global AC OK/Power Fail

Global AC OK is an isolated transistor of an optocoupler providing a minimum of 5 ms warning of loss of output regulation. The signal is fully isolated and the collector and emitter must be connected externally.

Maximum sink current 2 mA, maximum voltage 60 V.

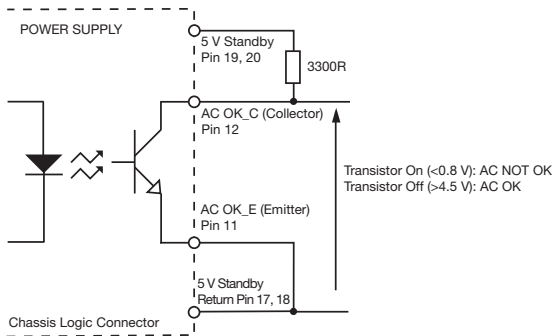

Global DC OK

Global DC OK is an isolated transistor of an optocoupler providing warning that the output voltage has fallen below 90% of nominal. The signal is fully isolated and the collector and emitter must be connected externally.

Maximum sink current 2 mA, maximum voltage 60 V. On Dual output module, DC OK monitors V1 output only.

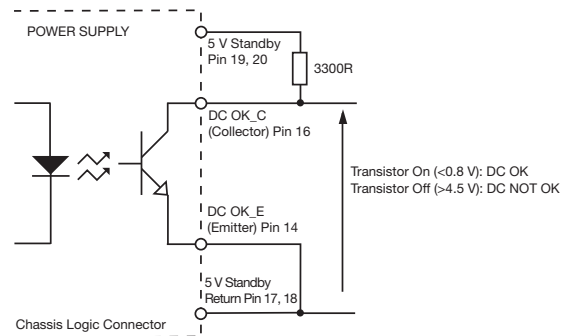

Global Inhibit

Global Inhibit is an isolated control signal input which turns the power supply off by supplying 2 to 5 mA into the pin.

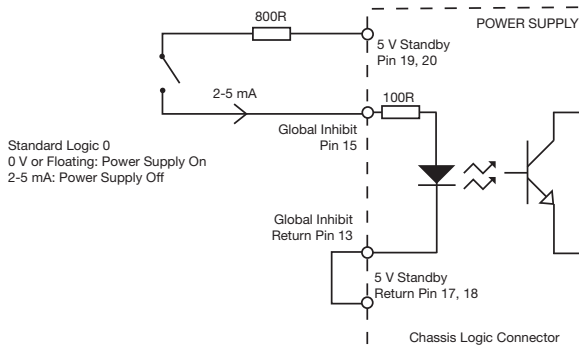

Module Inhibit

Module Inhibit signal is an isolated control signal which turns the module off by supplying 2 to 5 mA into the pin.

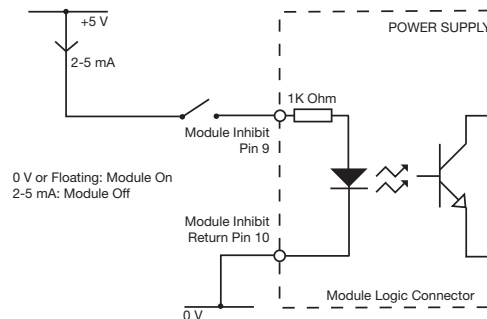

Module DC OK

Module DC OK is a nominal "ON" isolated transistor of an optocoupler which provides a warning of the loss of output regulation on the main output of the module. Maximum sink current 2 mA, maximum voltage 60 V.

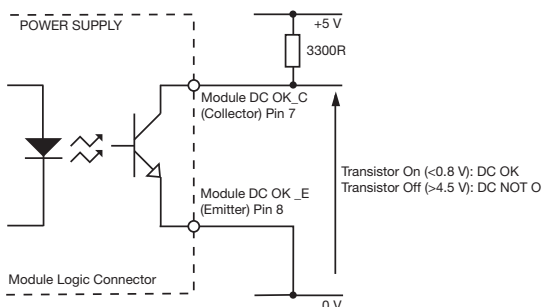

Current Share

Connecting pins 3 and 4 of like voltage modules (4 maximum) within the same chassis will force the current to share between the outputs. For paralleling modules in separate chassis, connect pin 2 to pin 2 and pin 8 to pin 8 of the chassis logic signal connector, J2.

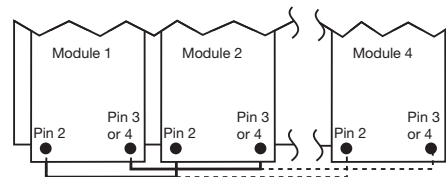

Mechanical Details

N12 with Standard Barrier Input Terminal

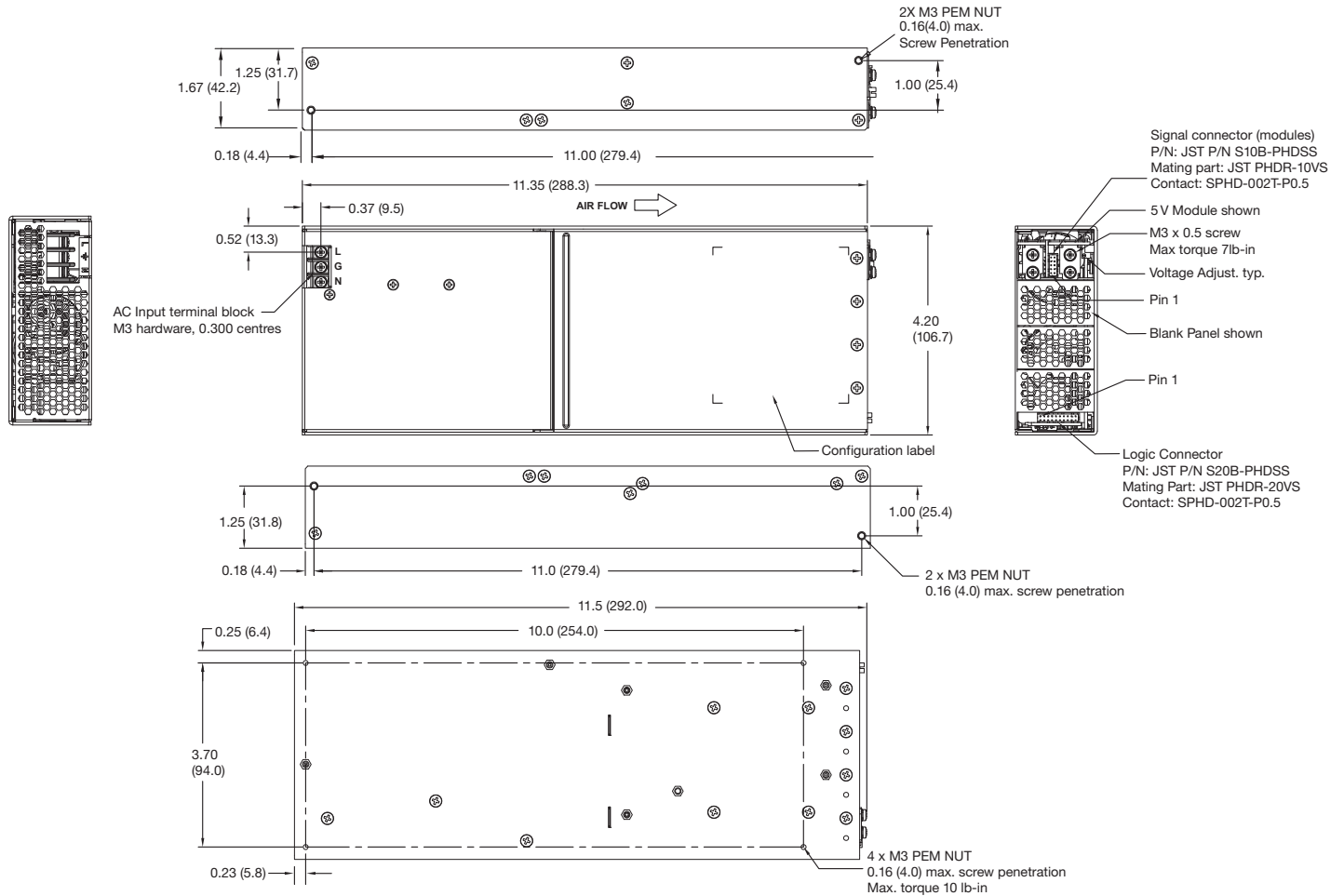

N12 with Optional Faston Output (A03)

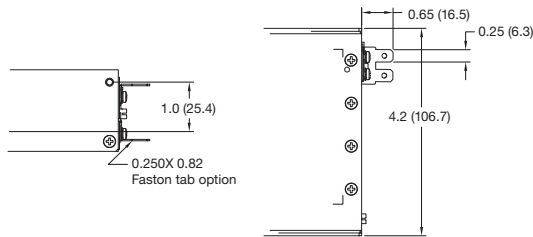

Chassis Logic Signal Connector

J2 Logic BD Connector			
Pin	Function	Pin	Function
1	SCL_USER	11	GL_ACOK_E
2	GINH_SHARE	12	GL_ACOK_C
3	SDA_USER	13	GL_INH_RTN
4	I2C_A2	14	GL_DCOK_E
5	I2C_A0	15	GL_INH
6	NC	16	GL_DCOK_C
7	I2C_A1	17	5V_SB_RTN
8	GND	18	5V_SB_RTN
9	NC	19	5V_SB
10	NC	20	5V_SB

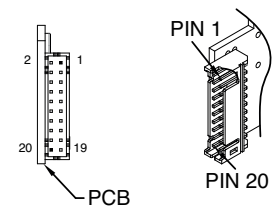

Notes

- All dimensions in inches (mm).
- Tolerance .xx = ±0.02 (0.50); .xxx = ±0.01 (0.25)
- Weight: With 1 module: 2.75 lbs (1.25 kg)
With 2 modules: 2.90 lbs (1.32 kg)
With 3 modules: 3.05 lbs (1.38 kg)
With 4 modules: 3.20 lbs (1.45 kg)

Mechanical Details

N12 with Optional IEC320 Input Terminal (A04)

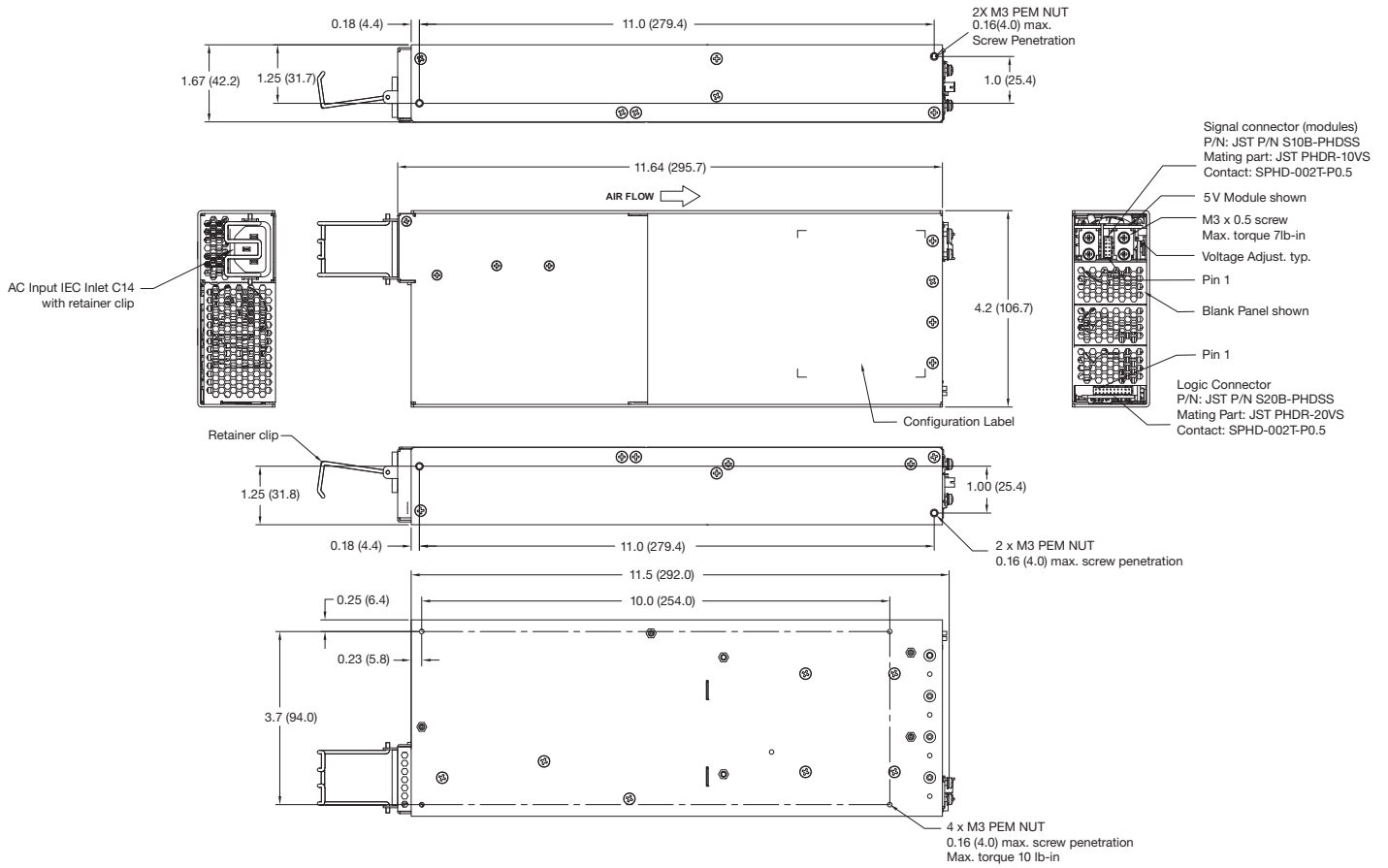

N12 with Combined Optional IEC Inlet and Faston Output (C10)

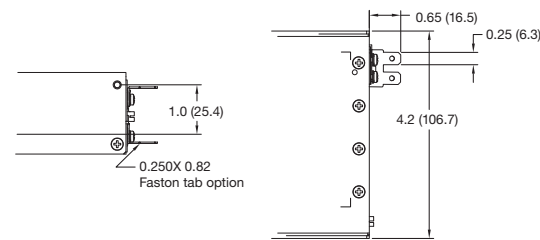

Chassis Logic Signal Connector

J2 Logic BD Connector			
Pin	Function	Pin	Function
1	SCL_USER	11	GL_ACOK_E
2	GINH_SHARE	12	GL_ACOK_C
3	SDA_USER	13	GL_INH_RTN
4	I2C_A2	14	GL_DCOK_E
5	I2C_A0	15	GL_INH
6	NC	16	GL_DCOK_C
7	I2C_A1	17	5V_SB_RTN
8	GND	18	5V_SB_RTN
9	NC	19	5V_SB
10	NC	20	5V_SB

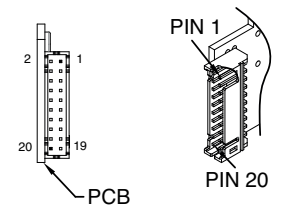

Notes

- All dimensions in inches (mm).
- Tolerance .xx = ±0.02 (0.50); .xxx = ±0.01 (0.25)
- Weight: With 1 module: 2.75 lbs (1.25 kg)
With 2 modules: 2.90 lbs (1.32 kg)
With 3 modules: 3.05 lbs (1.38 kg)
With 4 modules: 3.20 lbs (1.45 kg)

Signals & Controls

Analogue Signals

Name	Global, On Chassis	Local On Module	Description
AC OK	•	•	Global AC OK is an isolated transistor of an optocoupler providing a minimum of 5 ms warning of loss of output regulation. The signal is fully isolated and the collector and emitter must be connected externally. Maximum sink current 2 mA. Maximum voltage 60 V.
DC OK	•	•	Global DC OK is an isolated transistor of an optocoupler providing warning that the output voltage has fallen below 90% of nominal. The signal is fully isolated and the collector and emitter must be connected externally. Maximum sink current 2 mA. Maximum voltage 60 V.
	•	•	Module DC OK is a nominal 'ON' isolated transistor of an optocoupler which provides a warning of loss of output regulation on the main output module. Maximum sink current 2 mA. Maximum voltage 60 V.
Inhibit	•	•	Global inhibit is an isolated control signal input which turns the power supply off by supplying 2 to 5 mA into the pin.
	•	•	Module inhibit signal is an isolated control signal which turns the module off by supplying 2 to 5 mA into the pin.
Voltage Program	•	•	Non-isolated analogue input, referenced to the module -Sense, pin 1. 1.5VDC - 5VDC input will program the module output from 0V to Vmax.
Current Share	•	•	Connecting pins 3 and 4 of like voltage modules (4 maximum) will force the current to share between the outputs.

Digital Signals

Name	Description
Select Module (PAGE)	Each module can be addressed individually via this PMBus commands.
On/Off (OPERATION)	The command will turn off or turn on the selected module.
Voltage Program (VOUT_COMMAND)	The command will set the output voltage of the selected module. If multiple modules are connected in parallel, this command will be applied to all paralleled modules.
Maximum Voltage Level (VOUT_MAX)	This command will set an upper limit of the selected output module voltage. If a voltage is programmed via Voltage Program (VOUT_COMMAND) above to be higher than VOUT max. This maximum voltage level will take priority and limit the voltage to this set level. If multiple modules are connected in parallel, this command will be applied to all paralleled modules.
Overvoltage Alarm Set Point (VOUT_OV_FAULT_LIMIT)	The command will set the selected module's voltage threshold value such that any measured output voltage above this threshold will signal a fault. If multiple modules are connected in parallel, this command will be applied to all paralleled modules.
OCP Set Point (IOUT_OC_FAULT_LIMIT)	The command will set the selected module's current threshold value such that any measured output current above this threshold will signal a fault. If multiple modules are connected in parallel, this command will be applied to all paralleled modules.
Output Voltage Readback (READ_VOUT)	This command will return the actual measured output voltage value of the selected module.
Output Current Readback (READ_IOUT)	This command will return the actual measured current voltage value of the selected module.
Unit Temp Readback (READ_TEMPERATURE1)	This command will return the actual measured highest temperature value from the various monitored points.
XP Power Readback (MFR_ID)	This command will return the XP Power name as the manufacturer.
Stock Key Readback (MFR_MODEL)	This command will return the STOCK KEY of the product and not the model number. This assumes the product has been configured by XP and not via distribution.
Combined Fault Alarm (STATUS_MFR_SPECIFIC)	OCP, SCP, OTP, UVP, OVP
Output Overvoltage Warning (STATUS_VOUT)	This command will signal 3 different output voltage faults. Vout >10% warning of Vprogram, Vout >15% fault of Vprogram & when a voltage is programmed greater than the overvoltage set point.
Output Over Current Warning (STATUS_IOUT)	OC Fault & Warning
Over Temp Warning (STATUS_TEMPERATURE)	OT Fault & Warning as set by OT_Fault and OT_Warn
Fan Fail (Optional) (STATUS_FAN_1_2)	This command will signal 2 different fan fail conditions when the 3 wire fan option has been selected. Fan speed below 3000 RPM fault expected speed and below 5000 RPM warning expected speed.