

3 Phase 1600 Watts

- 3 Phase Input
- 342 - 528 VAC Input
- Configurable For Fast Time To Market
- Semi F47 Compliant
- Flexible Series & Parallel Capability
- -20 °C Operation
- Fan Speed Control
- 3 Year Warranty



Dimensions:

XT16 fleXPower:

11.00 x 7.00 x 2.50" (279.4 x 177.8 x 63.5 mm)

The 3 phase XT16 fleXPower series is a modular power supply which can be configured into a bespoke solution for quick delivery of samples, prototypes and low volume production with up to 1600 Watts of output power. The output comprises of up to 7 modules chosen from 44 single output modules and 16 dual output modules ranging from 3.3V at 66W to 60V at 750W. The modules can be placed in series or in parallel to give a single output at the chassis rating. Modules of unlike power can be paralleled and will current share within 10%. Signals are floating and allow for configuration as active low or active high and include AC OK, global DC OK, module DC OK and current monitor. There is a global inhibit signal which can alternatively be configured as a global enable and a 5 V standby supply which is present whenever the AC supply is applied.

XT16 fleXPower consists of a chassis in which there are 14 slots, allowing for up to 7 individual outputs. A single phase input version is available, see fleXPower datasheet for details.

Models & Ratings

Max Power 342 to 528 VAC	Standby	Capacity	Width	Code
1600 W	5 V/2 A	14 Slots	7" (177.8 mm)	XT16

Notes

For mechanical details, refer to page 7.

Summary

Characteristic	Minimum	Typical	Maximum	Units	Notes & Conditions
Input Voltage Range	342		528	VAC	4 wire 3 phase (no neutral)
Efficiency			89	%	
Operating Temperature	-20		+70	°C	
EMC	EN55032 Level B Conducted & Level A Radiated, EN61000-4, EN61000-3, SEMI F47				
Safety Approvals	ITE & Industrial, CE & UKCA meets all applicable directives & legislation.				

Input

Characteristic	Minimum	Typical	Maximum	Units	Notes & Conditions
Input Voltage Range	342		528	VAC	4 wire 3 phase (no neutral), 580 VAC 5s.
Input Frequency	47		63	Hz	
Power Factor	0.93				at 528 VAC & full load.
Input Current - per phase		3		A	380 VAC.
		2.4		A	480 VAC.
Inrush Current			<20	A	cold start, 25 °C.
Earth Leakage Current		<1.5		mA	at 528 VAC.
Loss of Phase	Shut down after 1s, auto recovery.				
Input Protection	T10 A / 250 V internal fuse fitted in each line.				

Output

Characteristic	Minimum	Typical	Maximum	Units	Notes & Conditions
Output Voltage	3.3		60	VDC	See Modules table.
Output Voltage Adjustment					See Modules table.
Minimum Load					No min load required for 2 slot, 3 slot or 4 slot single output or 6 x dual output modules. 5x dual outputs require 10% load on V1 to meet specified regulation on V2.
Start Up Delay		1.8 / 5		s	At 480 / 342 VAC.
Hold Up Time	20			ms	With full output load.
Line Regulation			<0.1	%	
Load Regulation			<1	%	
Ripple & Noise			50 / 1	mV / % pk-pk	At 20 MHz bandwidth whichever is the greater. 6E module has 1.5% max on V1 & V2. 6N modules has 1.5% max on V1 and 3% max on V2.
Overvoltage Protection	115		130	% V nom	
Overload Protection	110		140	% I nom	
Short Circuit Protection					Continuous trip & restart (hiccup mode).
Temperature Coefficient			0.03	%/°C	
Overtemperature Protection			115	°C	Measured internally recycle mains to reset.
Remote Sense			0.5	V	Compensate for a maximum voltage drop for 0.5 V.
Enable & Inhibit					See signals page.
Current Share					See signals page.
Housekeeping Voltage		5 V / 2 A			From chassis.

General

Characteristic	Minimum	Typical	Maximum	Units	Notes & Conditions
Efficiency		89		%	See fig. 3 & 4.
Isolation: Input to Output Input to Ground Output to Ground	4000			VAC	2 x MOPP.
	1500			VAC	1 x MOPP.
	250			VDC	
Switching Frequency		60		kHz	For PFC converter.
		200			For modules.
Mean Time Between Failure		225		kHrs	MIL-STD-217F at 25 °C GB.

Environmental

Characteristic	Minimum	Typical	Maximum	Units	Notes & Conditions
Operating Temperature	-20		+70	°C	For operation above +50 °C, derate linearly to 50% load at +70 °C. Reverse air option derate from +40 °C to half load at +60 °C.
Cooling	Forced air cooling (via field-replaceable internal fan). Fan speed control as standard.				
Storage Temperature	-40		+85	°C	
Humidity	5		95	%RH	Non condensing.
Operating Altitude			3048	m	
Shock	MIL-STD-810 Method 516.4 Procedure 1, 30 g, half sine, 6 axes.				
Vibration	MIL-STD-810 Method 514.4 Procedure 1, 1 g rms, 5-500 Hz, 3 axes.				

EMC: Emissions

Phenomenon	Standard	Class	Notes & Conditions
Conducted	EN55032	B	
Radiated	EN55032	A	
Harmonic Current	EN61000-3-2	A	>480 VAC
Harmonic Fluctuations	EN61000-3-3	A	

EMC: Immunity

Phenomenon	Standard	Test Level	Criteria	Notes & Conditions
Low Voltage PSU EMC	EN61204-3	High Severity Level	As below	
ESD	EN61000-4-2	4	A	±8 kV contact, ±15 kV Air
Radiated	EN61000-4-3	10 V/m	A	
EFT	EN61000-4-4	3	A	
Surge	EN61000-4-5	Installation Class 4	A	
Conducted	EN61000-4-6	3	A	
Magnetic Fields	EN61000-4-8	4	A	
Dips and Interruptions	EN55024 (380 VAC)	Int >100% (0 VAC) 8.4 ms	A	
		Int 100% (0 VAC) 16.7 ms	A	
		Dip 60% (228 VAC) 200 ms	B	
		Dip 30% (114 VAC) 500 ms	B	
		Dip 20% (76 VAC) 5000 ms	B	
	EN55024 (480 VAC)	Int >100% (0 VAC) 8.4 ms	A	
		Int 100% (0 VAC) 16.7 ms	A	
		Dip 60% (228 VAC) 200 ms	B	
		Dip 30% (114 VAC) 500 ms	B	
		Dip 20% (76 VAC) 5000 ms	B	
	SEMI F47 (380/480V)	Dip 20% (304/384 VAC) 1000 ms	A	
		Dip 30% (266/336 VAC) 500 ms	A	
Dip 50% (190/240 VAC) 200 ms		A		

Safety Approvals

Safety Agency	Safety Standard	Notes & Conditions
CB Report	IEC60950-1:2005 Ed 2 / IEC62368-1:2014	Information Technology
UL	UL 62368-1 & CAN/CSA C22.2 No. 62368-1-14	Information Technology
EN	EN62368-1:2014/A11:2017	Information Technology
CE	To Low Voltage and ROHS directives	
Equipment Protection Class	Class I	
CE	Meets all applicable directives	
UKCA	Meets all applicable legislation	

Signals

Global AC OK/Power Fail

Global AC OK is an isolated transistor of an optocoupler providing a minimum of 5 ms warning of loss of output regulation. The signal is fully isolated and the collector and emitter must be connected externally.

Maximum sink current 2 mA, maximum voltage 20 V.

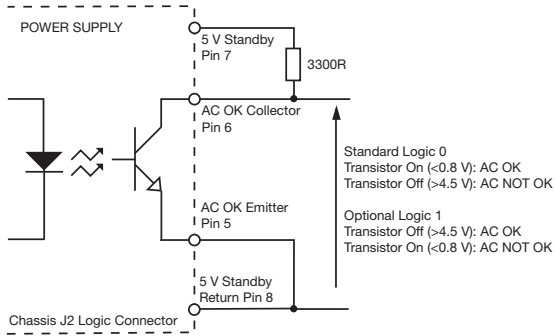

Global DC OK

Global DC OK is an isolated transistor of an optocoupler providing warning that the output voltage has fallen below 90% of nominal. The signal is fully isolated and the collector and emitter must be connected externally.

Maximum sink current 2 mA, maximum voltage 20 V.
On Dual output module, DC OK monitors V1 output only.

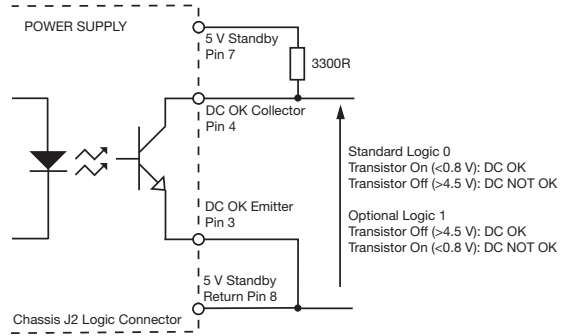

Global Inhibit

Global Inhibit is an isolated control signal input which turns the power supply off by supplying 2 to 5 mA into the pin. Global Enable option available, see 'Other Option Codes' table.

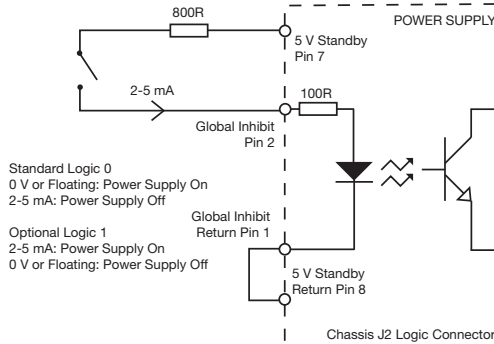

Fan Fail

Open connector signal warns of any fan failure.
Note: Can use 5V standby for 5V EXT.

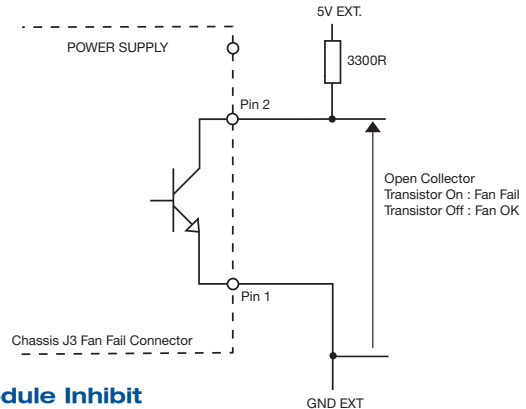

Module DC OK

Module DC OK is a nominal "ON" isolated transistor of an optocoupler which provides a warning of the loss of output regulation on the main output of the module.

Maximum sink current 2 mA, maximum voltage 20 V.

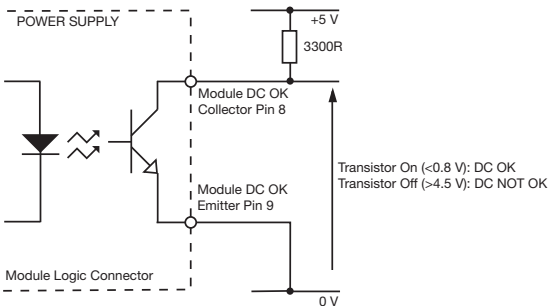

Current Share

Connecting pins 2 and 4 of like voltage modules (4 maximum) within the same chassis or separate chassis will force the current to share between the outputs. Different slot width modules share in proportion to their output current rating.

Module Inhibit

Module Inhibit signal is an isolated control signal which turns the module off by supplying 2 to 5 mA into the pin.

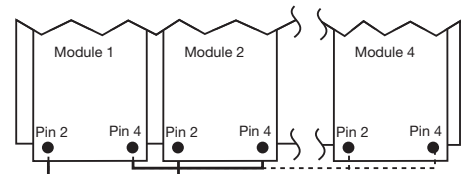
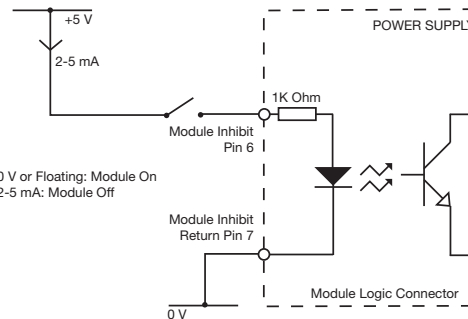

Module Mechanical Details

Single Output

2 Slot Modules

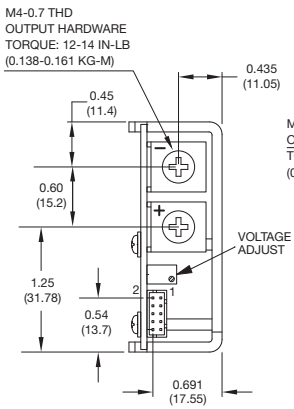

2 Slot Modules (1R / 2R Peak)

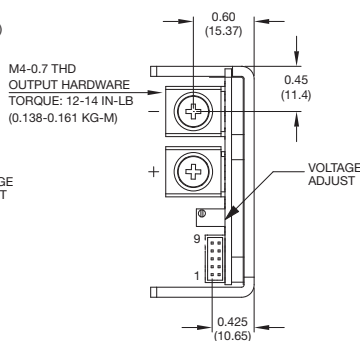

3 Slot Modules (3R Peak)

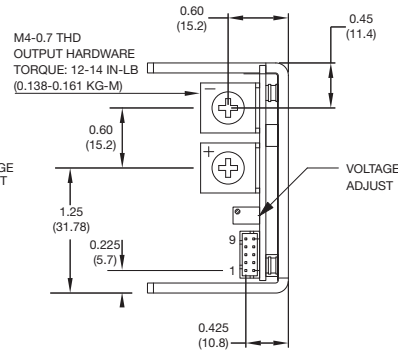

4 Slot Modules

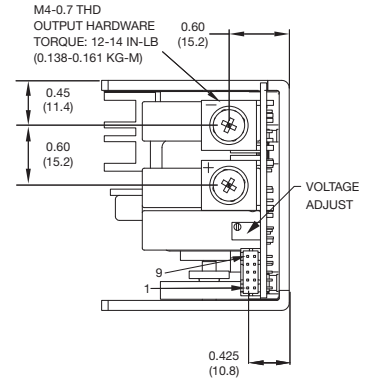

Notes

- All dimensions in inches (mm). Tolerance: .xx = ±0.02 (±0.50). .xxx = ±0.01 (±0.25).
- Weight: 2/2R Slot: 0.48 lb (218 g) approx.
3 Slot: 0.74 lb (335 g) approx.
4 Slot: 0.95 lb (431 g) approx.
- Mating plug: JST part no. PHDR-10VS.
- Contact: 26-22 AWG JST part no. SPHD-001T-P0.5.
- Connector kit available order part no. fleXPower CONKIT.

Single Output: Module Logic Connector Pinouts

Pin	Function	Pin	Function
1	Sense +	6	Inhibit
2	Sense -	7	Module Inhibit Return
3	V Prog	8	DC OK Collector
4	I Share	9	DC OK Emitter
5	Not used	10	Not used

Dual Output

2 Slot Modules

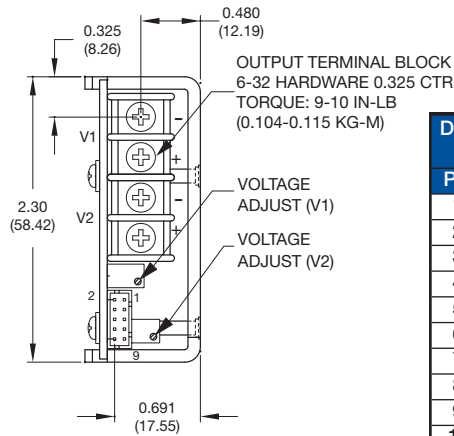

Dual Output: Module Logic Connector Pinouts

Pin	Function
1	V1 Sense +
2	V1 Sense -
3	Not used
4	Not used
5	V2 Sense +
6	Inhibit
7	Module Inhibit Return
8	DC OK Collector
9	DC OK Emitter
10	V2 Sense -

Notes

- All dimensions in inches (mm). Tolerance: .xx = ±0.02 (±0.50); .xxx = ±0.01 (±0.25).
- Weight: 0.48 lb (218 g) approx.
- Mating plug: JST part no. PHDR-10VS.
- Contact: 26-22 AWG JST part no. SPHD-001T-P0.5.
- Connector kit available order part no. fleXPower CONKIT.

Mechanical Details

XT16 Chassis

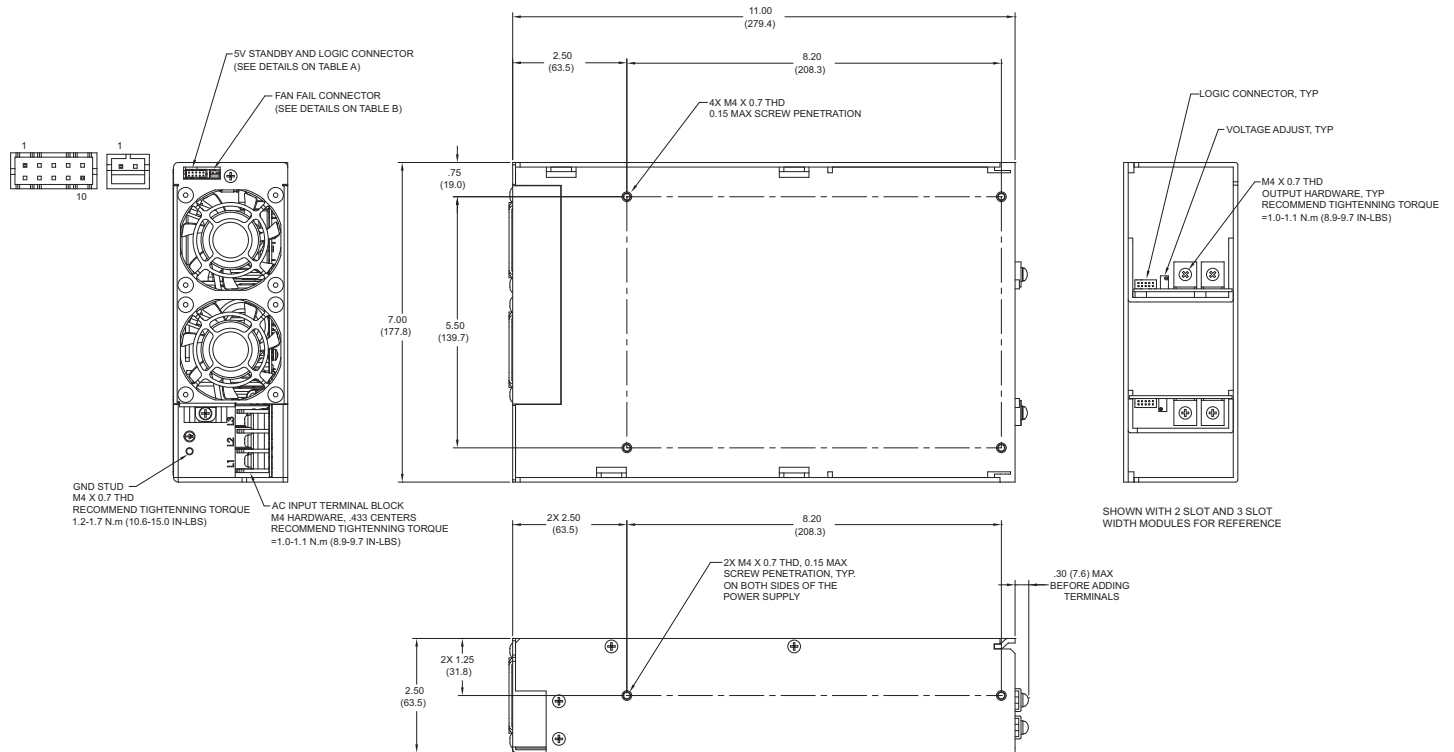

Table A: Logic Connector JST Part no. S10B-PHDSS(LF)	
Pin	Function
1	Global Inhibit Return
2	Global Inhibit
3	Global DC OK Emitter
4	Global DC OK Collector
5	Global AC OK Emitter
6	Global AC OK Collector
7	5 V Standby
8	5 V Standby Return
9	Not Used
10	Not Used

Table B: Fan Fail Connector JST Part no. S2B-PH-K (LF)	
Pin	Function
1	Fan Fail Emitter
2	Fan Fail Collector

Notes

- All dimensions in inches (mm).
Tolerance: .xx = ±0.02 (±0.50); .xxx = ±0.01 (±0.25).
- Weight: 4.32 lb (1.91 kg) approx.

- Logic Connector:
Mating plug: JST part no. PHDR-10VS.
Contact: 26-22 AWG JST part no. SPHD-001T-P0.5.
- Fan Fail Connector:
Mating plug: JST part no. PHR-2
Contact: 30-24 AWG JST part no. SPH-002T-P0-5S