

3 Phase 1500 Watts

- Configurable for fast time to market
- Flexible series & parallel capability
- ITE approvals
- 3 phase input 180 to 264VAC
- 1-14 outputs
- Variable speed fan (optional)
- Fully featured signals & controls
- -20°C to +70°C operating temperature
- 3 year warranty



Dimensions:

XTL15 fleXPower:

11.00 x 7.00 x 2.50" (279.4 x 177.8 x 63.5 mm)

The 3 phase XTL15 fleXPower series is a modular power supply which can be configured into a bespoke solution for quick delivery of samples, prototypes and low volume production with upto 1500 Watts of output power. The output comprises of up to 7 modules chosen from 44 single output modules and 16 dual output modules ranging from 3.3V at 66W to 60V at 750W. The modules can be placed in series or in parallel to give a single output at the chassis rating. Modules of unlike power can be paralleled and will current share within 10%. Signals are floating and allow for configuration as active low or active high and include AC OK, global DC OK and module DC OK. There is a global inhibit signal which can alternatively be configured as a global enable and a 5 V standby supply which is present whenever the AC supply is applied.

XTL15 fleXPower consists of a chassis in which there are 14 slots, allowing for up to 7 individual modules. All models have EN62368-1 and UL62368 approvals. A single phase input version is available, see fleXPower datasheet for details.

Models & Ratings

Max Power 180 to 264 VAC	Standby	Capacity	Width	Code
1500 W	5 V/1 A	14 Slots	7" (177.8 mm)	XTL15

Notes

For mechanical details, refer to page 7.

Summary

Characteristic	Minimum	Typical	Maximum	Units	Notes & Conditions
Input Voltage Range	180		264	VAC	4 wire 3 phase (no neutral), 300 VAC, 5s
Efficiency		88		%	Configuration dependent
Operating Temperature	-20		+70	°C	
Safety Approvals	ITE & Industrial, CE & UKCA meets all applicable directives & legislation.				

Configuration Examples

The XTL15 range allows for simple configuration of a custom modular power supply with up to seven outputs. The chassis consists of fourteen slots, and modules are either two, three or four slots wide.

CHASSIS

OUTPUT MODULES 1-7

OPTIONS

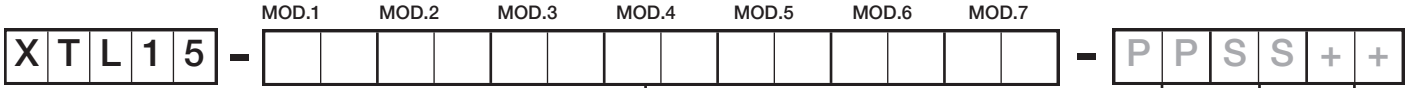

Step 1

XTL15 can accommodate up to seven modules, resulting in an extensive range of output combinations. However, as all modules are designed to fit across either 2, 3 or 4 slots in the chassis, configuration is very simple. Select the appropriate modules for your output requirements, ensuring that all modules will fit in the chassis. First, insert 4 series modules, ordered lowest voltage to highest. Next in order, insert 3 series modules, ordered lowest voltage highest. Follow with 2 series, then 5 series dual output, ordered alphabetically A-Z. Then 1 series, ordered lowest voltage to highest.

Step 2

Add any required options. These are grouped into three types; parallel options, series options and other options. The standard signal set for each chassis includes Global Inhibit, Global DC OK and Global AC OK, each having logic 0 operation. Optionally a logic 1 operating version of each is available along with reverse air flow. Also available is a fan speed control option, which is available separately or combined with previously listed options.

Single Output - Module Voltage/Current Rating						
Voltage	Current	Ipk	Power	Ppk	Slots	Code
3.3V	20.0 A	n/a	66 W	n/a	2	1C
3.3V	40.0 A	n/a	132 W	n/a	2	2C
3.3V	60.0 A	n/a	198 W	n/a	3	3C
5.0V	20.0 A	n/a	100 W	n/a	2	1D
5.0V	40.0 A	n/a	200 W	n/a	2	2D
5.0V	60.0 A	n/a	300 W	n/a	3	3D
8.0V	25.0 A	n/a	200 W	n/a	2	2H
10.0V	20.0 A	n/a	200 W	n/a	2	2I
10.0V	30.0 A	n/a	300 W	n/a	3	3I
12.0V	8.50 A	n/a	102 W	n/a	2	1J
12.0V	17.0 A	n/a	204 W	n/a	2	2J
12.0V	25.0 A	n/a	300 W	n/a	3	3J
12.0V	62.5 A	n/a	750 W	n/a	4	4J
15.0V	7.00 A	n/a	105 W	n/a	2	1L
15.0V	14.0 A	n/a	210 W	n/a	2	2L
15.0V	20.0 A	n/a	300 W	n/a	3	3L
15.0V	50.0 A	n/a	750 W	n/a	4	4L
18.0V	16.7 A	n/a	300 W	n/a	3	3N
24.0V	5.00 A	n/a	120 W	n/a	2	1P
24.0V	10.5 A	n/a	252 W	n/a	2	2P
24.0V	17.0 A	n/a	408 W	n/a	3	3P
24.0V	31.5 A	n/a	750 W	n/a	4	4P
24.0V	5.00 A	10.0 A	120 W	240 W	2	1R ⁽¹⁾
24.0V	10.5 A	21.0 A	252 W	504 W	2	2R ⁽¹⁾
24.0V	17.0 A	34.0 A	408 W	816 W	3	3R ⁽¹⁾
28.0V	4.50 A	n/a	126 W	n/a	2	1Q
28.0V	9.00 A	n/a	252 W	n/a	2	2Q
28.0V	14.0 A	n/a	392 W	n/a	3	3Q
28.0V	26.8 A	n/a	750 W	n/a	4	4Q
30.0V	8.4 A	n/a	252 W	n/a	2	2S
30.0V	13.5 A	n/a	405 W	n/a	3	3S
36.0V	3.50 A	n/a	126 W	n/a	2	1U
36.0V	7.00 A	n/a	252 W	n/a	2	2U
36.0V	11.0 A	n/a	396 W	n/a	3	3U
36.0V	21.0 A	n/a	750 W	n/a	4	4U
42.0V	9.05 A	n/a	400 W	n/a	3	3V
48.0V	2.50 A	n/a	120 W	n/a	2	1W
48.0V	5.20 A	n/a	249 W	n/a	2	2W
48.0V	8.50 A	n/a	408 W	n/a	3	3W
48.0V	15.7 A	n/a	750 W	n/a	4	4W
60.0V	2.00 A	n/a	120 W	n/a	2	1Y
60.0V	4.20 A	n/a	252 W	n/a	2	2Y
60.0V	7.00 A	n/a	420 W	n/a	3	3Y
60.0V	12.5 A	n/a	750 W	n/a	4	4Y

Parallel Option Codes	
Code	Description
00	No parallel required
12	Modules 1 & 2
13	Modules 1 to 3
14	Modules 1 to 4
23	Modules 2 & 3
24	Modules 2 to 4
25	Modules 2 to 5
34	Modules 3 & 4
35	Modules 3 to 5
40	Modules 1 & 2, 3 & 4

Series Option Codes	
Code	Description
00	No series required
12	Modules 1 & 2
13	Modules 1 to 3
23	Modules 2 & 3
24	Modules 2 to 4
40	Modules 1 & 2, 3 & 4

Other Option Codes	
Code	Description
01	Reverse Air
02	Global Enable - Logic 1
03	Option 01 & 02
04	Global DC OK - Logic 1
05	Option 01 & 04
06	Option 02 & 04
07	Option 01, 02 & 04
08	AC OK - Logic 1
09	Option 01 & 08
10	Option 02 & 08
11	Option 01, 02 & 08
12	Option 04 & 08
13	Option 01, 04 & 08
14	Option 02, 04 & 08
15	Option 01, 02, 04 & 08
16	Fan Speed Control
17	Option 01 & 16
18	Option 02 & 16
19	Option 04 & 16
20	Option 08 & 16
21	Option 01, 02 & 16
22	Option 01, 04 & 16
23	Option 01, 08 & 16
24	Option 02, 04 & 16
25	Option 02, 08 & 16
26	Option 04, 08 & 16
27	Option 01, 02, 04 & 16
28	Option 01, 02, 08 & 16
29	Option 02, 04, 08 & 16
30	Option 01, 02, 04, 08 & 16

Dual Output - Module Voltage/Current Rating					
Output 1		Output 2		Slots	Code
Voltage	Current	Voltage	Current		
5.0V	10.0 A	5.0V	10.0 A	2	5A
5.0V	10.0 A	3.3V	10.0 A	2	5B
12.0V	10.0 A	12.0V	8.0 A	2	5D
15.0V	8.0 A	15.0V	6.0 A	2	5E
15.0V	8.0 A	15.0V	6.0 A	2	6E*
15.0V	8.0 A	12.0V	8.0 A	2	5F
12.0V	10.0 A	5.0V	10.0 A	2	5G
12.0V	10.0 A	3.3V	10.0 A	2	5H
12.0V	10.0 A	2.0V	10.0 A	2	5J
15.0V	10.0 A	5.0V	10.0 A	2	5K
15.0V	10.0 A	3.3V	10.0 A	2	5L
15.0V	10.0 A	2.0V	10.0 A	2	5M
24.0V	6.0 A	5.0V	10.0 A	2	5N
24.0V	6.0 A	5.0V	10.0 A	2	6N*
24.0V	6.0 A	3.3V	10.0 A	2	5P
24.0V	6.0 A	2.0V	10.0 A	2	5Q

Note: Total power for dual output module must not exceed 175 W max. 5x modules require 10% load on V1 to meet specified regulation.

*No minimum load needed on output 1 for regulation.

Note:

1. Peak power available for 10 seconds with 35% duty cycle, if peak power rating is exceeded output may latch, recycle input to reset.

Example

XTL15-3C3L2C-000001

◀ Leave blank if no options are required

XTL15 - 1500 W industrial 3ø chassis, 14 module slots available.

- 3C - 3.3V @ 60.0 A. Three slot width module.
- 3L - 15.0V @ 20.0 A. Three slot width module.
- 2C - 3.3V @ 40.0 A. Two slot width module.
- 00 - No parallel option.
- 00 - No series option.
- 01 - Reverse air.

Note:

1. Fancard options 16-30 will occupy 2 slots. See mechanical drawing page 7.

Input

Characteristic	Minimum	Typical	Maximum	Units	Notes & Conditions
Input Voltage Range	180		264	VAC	4 wire 3 phase (no neutral), 300 VAC, 5s
Input Frequency	47		63	Hz	
Power Factor	0.93				
Input Current - per phase		6		A	180 VAC
		4		A	264 VAC
Inrush Current			60	A	cold start, 25 °C at 264 VAC
Earth Leakage Current			1	mA	at 264 VAC, 60Hz /<3.5 mA single fault
Input Protection	F15 A / 250 V internal fuse fitted in each line				

Output

Characteristic	Minimum	Typical	Maximum	Units	Notes & Conditions
Output Voltage	3.3		60	VDC	See Modules table
Output Voltage Adjustment	10			%	
Minimum Load					No min load required for 2 slot, 3 slot or 4 slot single output or 6 x dual output modules. 5x dual outputs require 10% load on V1 to meet specified regulation on V2
Start Up Delay		1.5	2.0	s	
Hold Up Time	20			ms	With full output load
Line Regulation			<0.1	%	
Load Regulation			<1	%	
Ripple & Noise			50 / 1	mV / % pk-pk	At 20 MHz bandwidth whichever is the greater. 6E module has 1.5% max on V1 & V2. 6N modules has 1.5% max on V1 and 3% max on V2.
Overvoltage Protection	115		130	% V nom	
Overload Protection	110		140	% I nom	
Short Circuit Protection					Continuous trip & restart (hiccup mode)
Temperature Coefficient			0.03	%/°C	
Overtemperature Protection				°C	Measured internally, auto reset
Remote Sense			0.5	V	Compensates for a maximum voltage drop for 0.5 V
Enable & Inhibit					See signals page
Current Share					See signals page
Standby		5 V / 1 A			From chassis

General

Characteristic	Minimum	Typical	Maximum	Units	Notes & Conditions
Efficiency		88		%	Configuration dependent
Isolation: Input to Output Input to Ground Output to Ground	3000			VAC	
	1500			VAC	
	250			VDC	
Switching Frequency		65		kHz	For PFC converter
		200		kHz	For modules
Mean Time Between Failure		225		kHrs	MIL-STD-217F at 25 °C GB

Environmental

Characteristic	Minimum	Typical	Maximum	Units	Notes & Conditions
Operating Temperature	-20		+70	°C	For operation above +50 °C, derate linearly to 50% load at +70 °C
Cooling	Forced air cooling (via field-replaceable internal fan). Fan speed control optional				
Storage Temperature	-40		+85	°C	
Humidity	5		95	%RH	Non condensing
Operating Altitude			3000	m	
Shock	MIL STD-810 Method 516.4 Procedure 1, 30 g, half sine, 6 axes				
Vibration	MIL STD-810 Method 514.4 Procedure 1, 1 g rms, 5-500 Hz, 3 axes				

EMC: Emissions

Phenomenon	Standard	Class	Notes & Conditions
Conducted	EN55032	A	
Radiated	EN55032	A	
Harmonic Fluctuations	EN61000-3-3		

EMC: Immunity

Phenomenon	Standard	Test Level	Criteria	Notes & Conditions
Low Voltage PSU EMC	EN61204-3	High Severity Level	As below	
ESD	EN61000-4-2	4	A	
Radiated	EN61000-4-3	10 V/m	A	
EFT	EN61000-4-4	3	A	
Surge	EN61000-4-5	Installation Class 3	A	
Conducted	EN61000-4-6	10 V/m	A	
Magnetic Fields	EN61000-4-8	3 A/m	A	
Dips and Interruptions	EN55024 (180 VAC)	Int >100% (0 VAC) 8.4 ms	A	
		Int 100% (0 VAC) 16.7 ms	A	
		Dip 60% (72 VAC) 200 ms	A	
		Dip 30% (126 VAC) 500 ms	A	
		Dip 20% (144 VAC) 5000 ms	A	
	EN55024 (208 VAC)	Int >100% (0 VAC) 10 ms	A	
		Int 100% (0 VAC) 20 ms	A	
		Dip 60% (83 VAC) 200 ms	A	
		Dip 30% (145 VAC) 500 ms	A	
	SEMI F47 (200 VAC)	Dip 20% (166 VAC) 5000 ms	A	
		Dip 33% (134 VAC) 500 ms	A	
		Dip 22% (156 VAC) 1000 ms	A	
		Dip 55% (90 VAC) 200 ms	A	

Safety Approvals

Safety Agency	Safety Standard	Notes & Conditions
CB Report	IEC62368-1	Information Technology
	IEC60950-1	Information Technology
UL	UL62368-1	Information Technology
EN	EN62368-1	Information Technology
CE	Low Voltage and ROHS directives	
Equipment Protection Class	Class I	
CE	Meets all applicable directives	
UKCA	Meets all applicable legislation	

Signals

Global AC OK/Power Fail

Global AC OK is an isolated transistor of an optocoupler providing a minimum of 5 ms warning of loss of output regulation. The signal is fully isolated and the collector and emitter must be connected externally.

Maximum sink current 2 mA, maximum voltage 20 V.

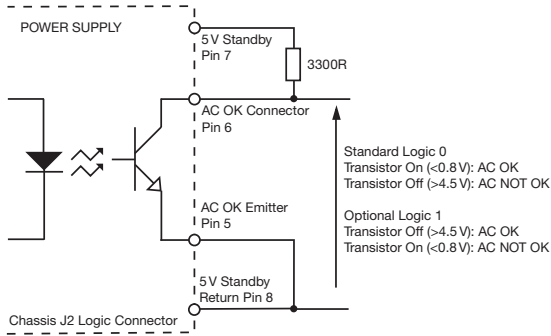

Global DC OK

Global DC OK is an isolated transistor of an optocoupler providing warning that the output voltage has fallen below 90% of nominal. The signal is fully isolated and the collector and emitter must be connected externally.

Maximum sink current 2 mA, maximum voltage 20 V.

On Dual output module, DC OK monitors V1 output only.

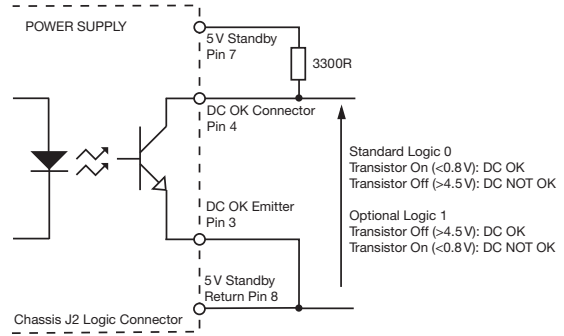

Global Inhibit

Global Inhibit is an isolated control signal input which turns the power supply off by supplying 2 to 5 mA into the pin. Global Enable option available, see 'Other Option Codes' table.

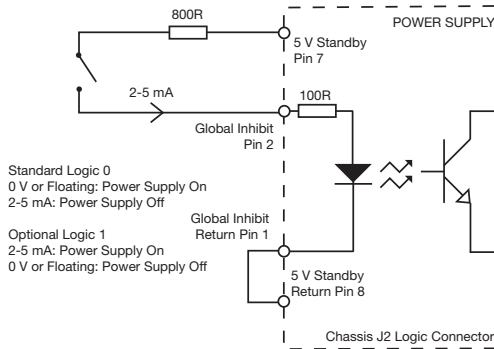

Fan Fail

When fan speed control fitted (option 16).

Open connector signal warns of any fan failure.

Note: Can use 5V standby for 5V EXT.

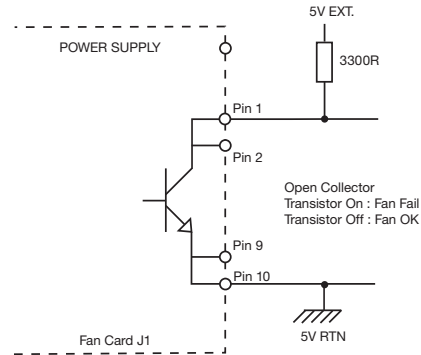

Module DC OK

Module DC OK is a nominal "ON" isolated transistor of an optocoupler which provides a warning of the loss of output regulation on the main output of the module.

Maximum sink current 2 mA, maximum voltage 20 V.

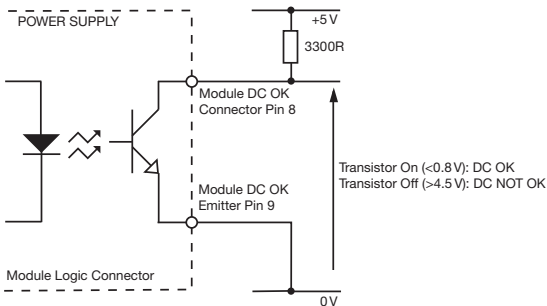

Module Inhibit

Module Inhibit signal is an isolated control signal which turns the module off by supplying 2 to 5 mA into the pin.

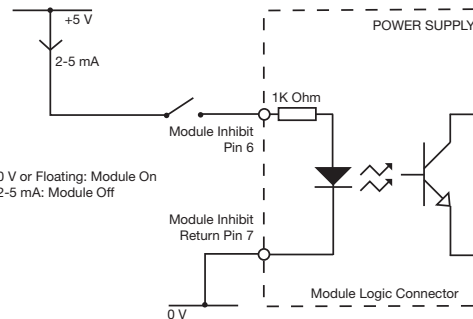

Current Share

Connecting pins 2 and 4 of like voltage modules (4 maximum) within the same chassis or separate chassis will force the current to share between the outputs. Different slot width modules share in proportion to their output current rating.

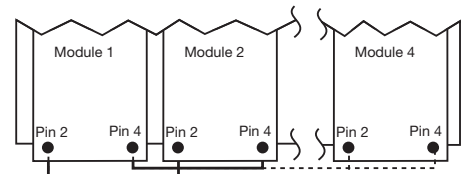

Module Mechanical Details

Single Output

2 Slot Modules

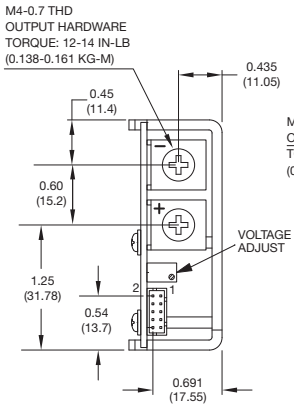

2 Slot Modules (1R / 2R Peak)

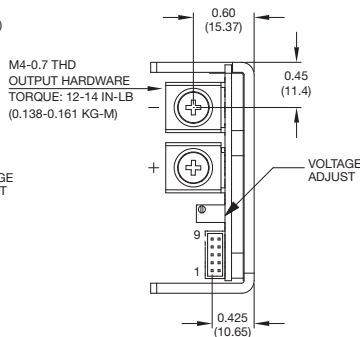

3 Slot Modules (3R Peak)

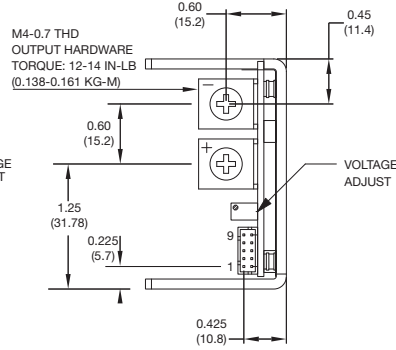

4 Slot Modules

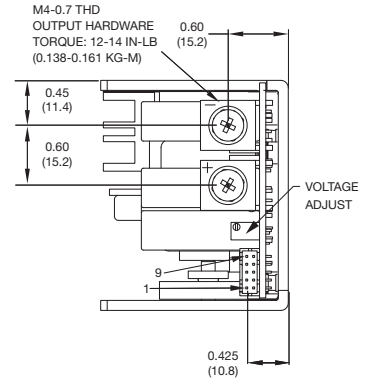

Notes

- All dimensions in inches (mm). Tolerance: .xx = ±0.02 (±0.50); .xxx = ±0.01 (±0.25)
- Weight: 2/2R Slot: 0.48 lb (218 g) approx.
3 Slot: 0.74 lb (335 g) approx.
4 Slot: 0.95 lb (431 g) approx.
- Mating plug: JST part no. PHDR-10VS.
- Contact: 26-22 AWG JST part no. SPHD-001T-P0.5.
- Connector kit available order part no. fleXPower CONKIT.

Single Output: Module Logic Connector Pinouts

Pin	Function	Pin	Function
1	Sense +	6	Inhibit
2	Sense -	7	Module Inhibit Return
3	V Prog	8	DC OK Collector
4	I Share	9	DC OK Emitter
5	Not used	10	Not used

Dual Output

2 Slot Modules

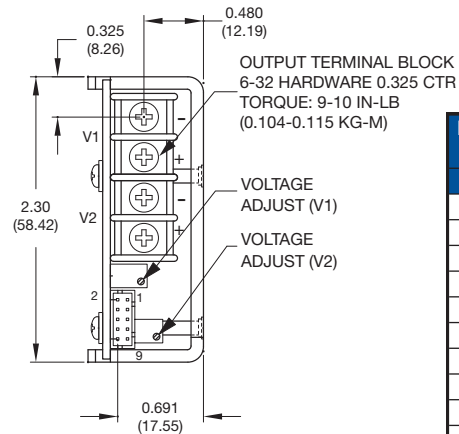

Dual Output: Module Logic Connector Pinouts

Pin	Function
1	V1 Sense +
2	V1 Sense -
3	Not used
4	Not used
5	V2 Sense +
6	Inhibit
7	Module Inhibit Return
8	DC OK Collector
9	DC OK Emitter
10	V2 Sense -

Notes

- All dimensions in inches (mm). Tolerance: .xx = ±0.02 (±0.50); .xxx = ±0.01 (±0.25)
- Weight: 0.48 lb (218 g) approx.
- Mating plug: JST part no. PHDR-10VS.
- Contact: 26-22 AWG JST part no. SPHD-001T-P0.5.
- Connector kit available order part no. fleXPower CONKIT.

Fan Speed Control Module

2 Slot Modules

Controls speed of fan(s) depending on output load and thermal environment of the power supply. Also provides warning of any fan failure.

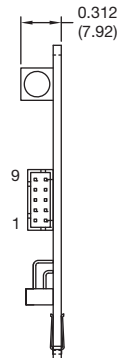

Fan Speed Control Module Connector Pinouts

Pin	Function
1	Fan Fail
2	Fan Fail
3	Not Used
4	Not Used
5	Not Used
6	Not Used
7	Not Used
8	Not Used
9	Ground
10	Ground

Notes

- All dimensions in inches (mm). Tolerance: .xx = ±0.02 (±0.50); .xxx = ±0.01 (±0.25)
- Weight: 0.10 lb (45 g) approx.
- Mating plug: JST part no. PHDR-10VS.
- Contact: 26-22 AWG JST part no. SPHD-001T-P0.5.
- Connector kit available order part no. fleXPower CONKIT.

Mechanical Details

XTL15 Chassis

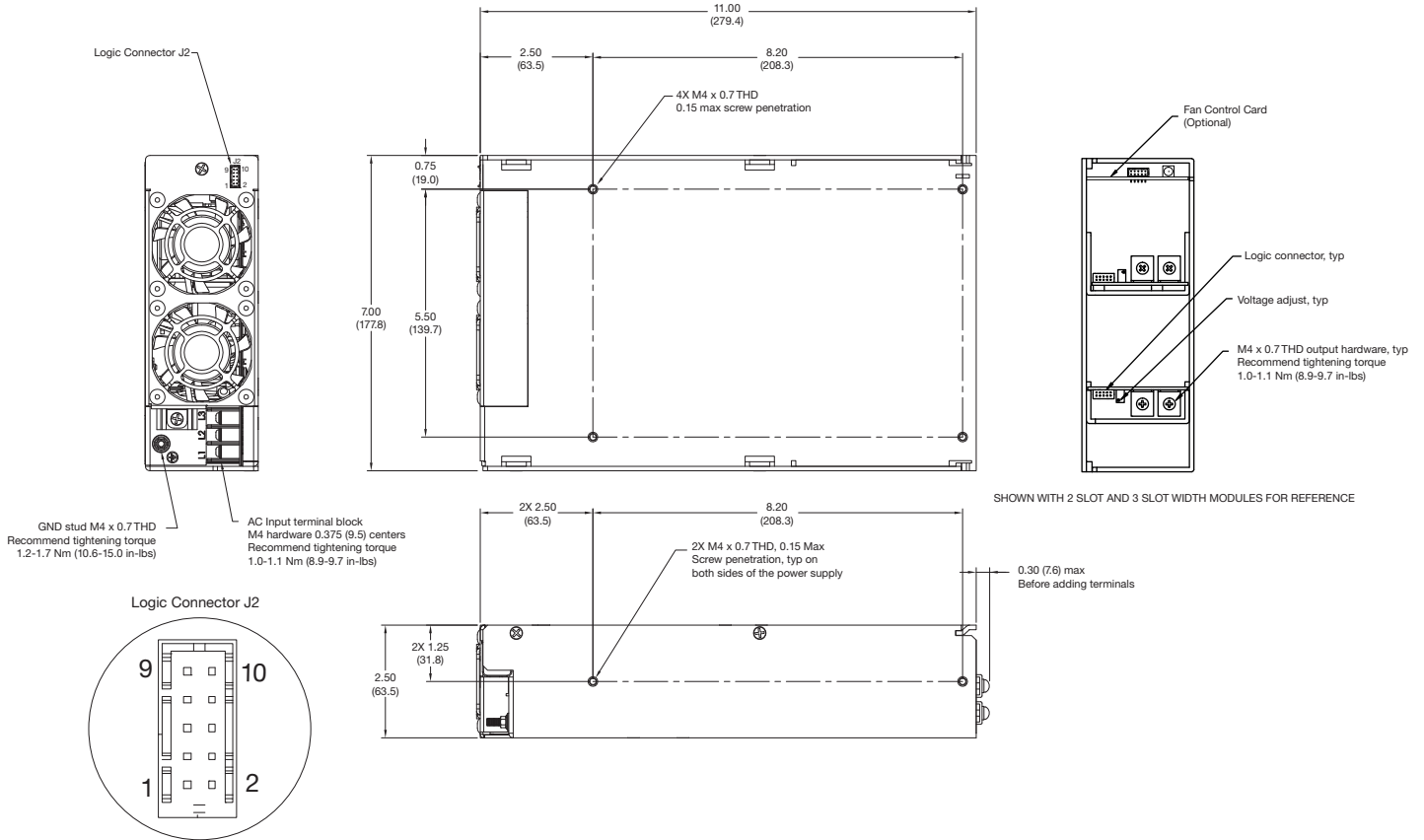

J2 Logic Connector JST Part no. S10B-PHDSS(LF)	
Pin	Function
1	Global Inhibit Return
2	Global Inhibit
3	Global DC OK Emitter
4	Global DC OK Collector
5	Global AC OK Emitter
6	Global AC OK Collector
7	5 V Standby
8	5 V Standby Return
9	Not Used
10	Not Used

Notes

- All dimensions in inches (mm).
Tolerance: .xx = ±0.02 (±0.50); .xxx = ±0.01 (±0.25).
- Weight: 4.1 lb (1.86 g) approx.

- Logic Connector:
Mating plug: JST part no. PHDR-10VS.
Contact: 26-22 AWG JST part no. SPHD-001T-P0.5.