

TMCM-3212 CANopen[®] Firmware Manual

Firmware Version V3.19 | Rev. V1.00 • 2016-APR-15

The TMCM-3212 is a three axes controller/driver modules for 2-phase bipolar stepper motors with separate differential encoder and separate HOME STOP switch inputs for each axis. Dynamic current control, and quiet, smooth and efficient operation are combined with stealthChop™, dcStep™, stallGuard™ and coolStep™ features. The modules offer four analog or digital inputs as well as four digital outputs in combination with a break chopper unit.

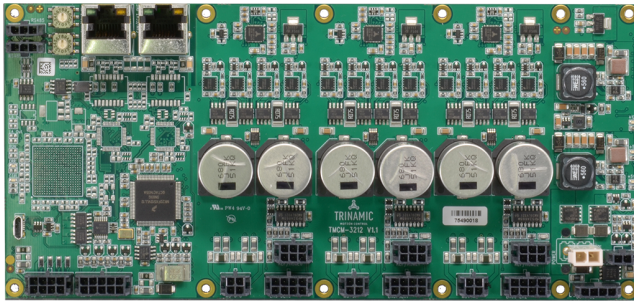

Figure 1: TMCM-3212

Features

- 3-Axes Stepper motor control
- CiA 402 drive profile
- Encoder Support
- coolStep™
- dcStep™
- stallGuard2™
- stealthChop™

Applications

- Lab-Automation
- Semiconductor Handling
- Manufacturing
- Robotics
- Factory Automation
- CNC
- Laboratory Automation

©2016 TRINAMIC Motion Control GmbH & Co. KG, Hamburg, Germany
Terms of delivery and rights to technical change reserved.
Download newest version at: www.trinamic.com



Read entire documentation;
Especially the supplemental directives on page 90.

Contents

1 Preface	6
1.1 General Features of this CANopen Implementation	6
1.2 Abbreviations used in this Manual	7
1.3 Firmware Update	7
1.4 Trinamic’s unique Features — easy to use with CANopen	7
1.4.1 stallGuard2	7
1.4.2 coolStep	8
2 Communication	9
2.1 Reference Model	9
2.2 NMT State Machine	10
2.3 Device Model	12
2.4 Object Dictionary	13
2.4.1 Object Indices on Multi-Axis Modules	13
3 Communication area	15
3.1 Detailed object specifications	15
3.1.1 Object 1000 _h : Device Type	15
3.1.2 Object 1001 _h : Error Register	15
3.1.3 Object 1005 _h : COB-ID SYNC Message	16
3.1.4 Object 1008 _h : Manufacturer Device Name	16
3.1.5 Object 1009 _h : Manufacturer Hardware Version	17
3.1.6 Object 100A _h : Manufacturer Software Version	17
3.1.7 Object 100C _h : Guard Time	17
3.1.8 Object 100D _h : Life Time Factor	18
3.1.9 Object 1010 _h : Store Parameters	18
3.1.10 Object 1011 _h : Restore Parameters	19
3.1.11 Object 1014 _h : COB-ID Emergency Object	20
3.1.12 Object 1015 _h : Inhibit Time EMCY	21
3.1.13 Object 1016 _h : Consumer Heartbeat Time	21
3.1.14 Object 1017 _h : Producer Heartbeat Time	21
3.1.15 Object 1018 _h : Identity Object	22
3.1.16 Object 1029 _h : Error Behaviour	22
3.1.17 Objects 1400 _h – 1403 _h : Receive PDO Communication Parameter	23
3.1.18 Objects 1600 _h – 1603 _h : Receive PDO Mapping Parameter	24
3.1.19 Objects 1800 _h – 1803 _h : Transmit PDO Communication Parameter	25
3.1.20 Objects 1A00 _h – 1A03 _h : Transmit PDO Mapping Parameter	26
4 Manufacturer specific area	28
4.1 Objects related to coolStep	28
4.2 Detailed object specifications	31
4.2.1 Object 2000 _h : Microstep resolution	31
4.2.2 Object 2001 _h : Microstep resolution	31
4.2.3 Object 2002 _h : Brake delay times	31
4.2.4 Object 2003 _h : Maximum current	32
4.2.5 Object 2004 _h : Standby current	32
4.2.6 Object 2005 _h : Limit switches	33
4.2.7 Object 200A _h : Enable drive delay time	33
4.2.8 Object 200B _h : Encoder parameters	34
4.2.9 Object 200C _h : Brake current feed	34
4.2.10 Object 2010 _h : Profile Start Velocity	35
4.2.11 Object 2011 _h : Profile A1	35



4.2.12	Object 2012 _h : Profile V1	35
4.2.13	Object 2013 _h : Profile D1	36
4.2.14	Object 2089 _h : Setting Delay	36
4.2.15	Object 208C _h : Velocity Dimension Index	36
4.2.16	Object 208E _h : Acceleration Dimension Index	37
4.2.17	Object 2092 _h : Chopper Blank Time	37
4.2.18	Object 2093 _h : Chopper Mode	38
4.2.19	Object 2094 _h : Chopper Hysteresis Decrement	38
4.2.20	Object 2095 _h : Chopper Hysteresis End	38
4.2.21	Object 2096 _h : Chopper Hysteresis Start	39
4.2.22	Object 2097 _h : Chopper Off Time	39
4.2.23	Object 2098 _h : Smart Energy Current Minimum	40
4.2.24	Object 2099 _h : Smart Energy Current Down Step	40
4.2.25	Object 209A _h : Smart Energy Hysteresis	41
4.2.26	Object 209B _h : Smart Energy Current Up Step	41
4.2.27	Object 209C _h : Smart Energy Hysteresis Start	41
4.2.28	Object 209D _h : Smart Energy Filter Enable	42
4.2.29	Object 209E _h : stallGuard2 Threshold	42
4.2.30	Object 20A1 _h : Short Protection Disable	43
4.2.31	Object 20A3 _h : Vsense	43
4.2.32	Object 20A4 _h : Stop on Stall	44
4.2.33	Object 20A5 _h : Smart Energy Threshold Speed	44
4.2.34	Object 2100 _h : Home Offset Display	44
4.2.35	Object 2101 _h : Actual Load Value	45
4.2.36	Object 2102 _h : Driver Error Flags	45
4.2.37	Object 2107 _h : Microstep resolution display	45
4.2.38	Object 210B _h : Step Counter	46
4.2.39	Object 2700 _h : TMCL Direct Communication	46
4.2.40	Object 2701 _h : Manufacturer Specific Mode	47
4.2.41	Object 2702 _h : Device Digital Inputs	47
4.2.42	Object 2703 _h : Device Digital Outputs	48
4.2.43	Object 2704 _h : CAN Bit Rate	48
4.2.44	Object 2705 _h : Node ID	49
4.2.45	Object 2706 _h : Store	49
4.2.46	Object 2707 _h : CAN Bit Rate Load	50
4.2.47	Object 2708 _h : Node ID Load	50
4.2.48	Object 270E _h : Device Analog Inputs	50

5	Profile specific area	51
5.1	Detailed object specifications	51
5.1.1	Object 605A _h : Quick stop option code	51
5.1.2	Object 605B _h : Shutdown option code	52
5.1.3	Object 605C _h : Disable operation option code	52
5.1.4	Object 605D _h : Halt option code	53
5.1.5	Object 605E _h : Fault reaction option code	53
5.1.6	Object 6060 _h : Modes of operation	54
5.1.7	Object 6061 _h : Modes of operation	54
5.1.8	Object 606A _h : Sensor selection code	55
5.1.9	Object 608F _h : Position Encoder Resolution	55
5.1.10	Object 60FD _h : Digital Inputs	56
5.1.11	Object 6502 _h : Supported Drive Modes	56



6	Profile position mode	58
6.1	Detailed Object Specifications	58
6.1.1	Object 6040 _h : Control Word	59
6.1.2	Object 6041 _h : Status Word	60
6.1.3	Object 6062 _h : Position Demand Value	61
6.1.4	Object 6063 _h : Position Actual Internal Value	61
6.1.5	Object 6064 _h : Position Actual Internal Value	61
6.1.6	Object 6065 _h : Following Error Window	62
6.1.7	Object 6067 _h : Position Window	62
6.1.8	Object 6068 _h : Position Window Time	63
6.1.9	Object 606C _h : Velocity Actual Value	63
6.1.10	Object 607A _h : Target Position	64
6.1.11	Object 607D _h : Software Position Limit	64
6.1.12	Object 6081 _h : Profile Velocity	64
6.1.13	Object 6082 _h : End Velocity	65
6.1.14	Object 6083 _h : Profile Acceleration	65
6.1.15	Object 6084 _h : Profile Deceleration	66
6.1.16	Object 6085 _h : Quick Stop Deceleration	66
6.1.17	Object 60F2 _h : Positioning Option Code	66
6.2	How to move a Motor in pp Mode	67
7	Profile velocity mode	68
7.1	Detailed Object Specifications	68
7.1.1	Object 6040 _h : Control Word	68
7.1.2	Object 6041 _h : Status Word	69
7.1.3	Object 6062 _h : Position Demand Value	70
7.1.4	Object 6063 _h : Position Actual Internal Value	70
7.1.5	Object 6064 _h : Position Actual Internal Value	71
7.1.6	Object 6065 _h : Following Error Window	71
7.1.7	Object 606C _h : Velocity Actual Value	72
7.1.8	Object 607D _h : Software Position Limit	72
7.1.9	Object 6083 _h : Profile Acceleration	73
7.1.10	Object 6085 _h : Quick Stop Deceleration	73
7.1.11	Object 60FF _h : Target Velocity	73
7.2	How to move a Motor in pv Mode	74
8	Homing mode	75
8.1	Homing Methods	76
8.1.1	Homing Method 1: Homing on negative Limit Switch and Index Pulse	76
8.1.2	Homing Method 2: Homing on positive Limit Switch and Index Pulse	76
8.1.3	Homing Method 3: Homing on positive Home Switch and Index Pulse	77
8.1.4	Homing Method 5: Homing on negative Home Switch and Index Pulse	77
8.1.5	Homing Method 17, 18, 19, and 21: Homing without Index Pulse	78
8.1.6	Homing Method 33 and 34: Homing on next Index Pulse	78
8.1.7	Homing Method 35: Current position as home position	79
8.2	Detailed Object Specifications	80
8.2.1	Object 6040 _h : Control Word	80
8.2.2	Object 6041 _h : Status Word	81
8.2.3	Object 606C _h : Velocity Actual Value	82
8.2.4	Object 607C _h : Home Offset	82
8.2.5	Object 6098 _h : Homing Method	83
8.2.6	Object 6099 _h : Homing Speeds	83
8.2.7	Object 609A _h : Homing Acceleration	83
8.2.8	Object 2100 _h : Home Offset Display	84



8.3 How to start a Homing in hm Mode 84

9 Figures Index 86

10 Tables Index 87

11 Supplemental Directives 90

11.1 Producer Information 90

11.2 Copyright 90

11.3 Trademark Designations and Symbols 90

11.4 Target User 90

11.5 Disclaimer: Life Support Systems 90

11.6 Disclaimer: Intended Use 90

11.7 Collateral Documents & Tools 91

12 Revision History 92

12.1 Firmware Revision 92

12.2 Document Revision 92



1 Preface

This document specifies objects and modes of operation of the Trinamic TMCM-3212 stepper motor control module with CANopen firmware. The CANopen firmware is designed to fulfill the CANopen DS402 and DS301 standards. This manual assumes that the reader is already familiar with the basics of the CANopen protocol, defined by the DS301 and DS402 standards of the CAN-CiA.

If necessary it is always possible to turn the module into a TMCL module by loading the TMCM-3212 TMCL firmware again through the USB interface, with the help of the firmware update function of the TMCL-IDE 3.0.

1.1 General Features of this CANopen Implementation

Main Characteristics

- Communication according to standard CiA-301 V4.1
- CAN bit rate: 20...1000kBit/s
- CAN ID: 11 bit
- Node ID: 1...127 (use vendor specific objects for changing the node ID)
- NMT services: NMT slave

SDO Communication

- 1 server
- Expedited transfer
- Segmented transfer
- No block transfer

PDO Communication

- Producer
- Consumer
- RPDOs
 - Axis 0: 1, 2, 3, 4
 - Axis 1: 65, 66, 67, 68
 - Axis 2: 129, 130, 131, 132
 - Transmission modes: asynchronous.
 - Dynamic mapping with max. 3 mapping entries.
 - Default mappings: according to CiA-402 for first three PDOs of each axis, manufacturer specific for other PDOs of each axis.
- TPDOs
 - Axis 0: 1, 2, 3, 4
 - Axis 1: 65, 66, 67, 68
 - Axis 2: 129, 130, 131, 132
 - Transmission modes: asynchronous, asynchronous with event timer, synchronous.
 - Dynamic mapping with max. 3 mapping entries.
 - Default mappings: according to CiA-402 for first three PDOs of each axis, manufacturer specific for other PDOs of each axis.



Further Characteristics

- SYNC: consumer (TPDOs 3, 67, 131 are synchronous PDOs)
- Emergency: producer
- RTR: supported only for node guarding/life guarding
- Heartbeat: consumer and producer

1.2 Abbreviations used in this Manual

Abbreviations	
CAN	Controller area network
CHGND	chassis ground / earth ground
COB	Communication object
FSA	Finite state automaton
FSM	Finite state machine
NMT	Network management
ID	Identifier
LSB	Least significant bit
MSB	Most significant bit
PDO	Process data object
PDS	Power drive system
RPDO	Receive process data object
SDO	Service data object
TPDO	Transmit process data object
EMCY	Emergency object
rw	Read and write
ro	Read only
hm	Homing mode
pp	Profile position mode
pv	Profile velocity mode
vm	Velocity mode

Table 1: Abbreviations used in this Manual

1.3 Firmware Update

The software running on the microprocessor consists of two parts, a boot loader and the CANopen firmware itself. Whereas the boot loader is installed during production and testing at TRINAMIC and remains untouched throughout the whole lifetime, the CANopen firmware can easily be updated by the user. The new firmware can be loaded into the module via the firmware update function of the TMCL-IDE, using the USB interface of the module.

1.4 Trinamic's unique Features — easy to use with CANopen

1.4.1 stallGuard2

stallGuard2 is a high-precision sensorless load measurement using the back EMF of the coils. It can be used for stall detection as well as other uses at loads below those which stall the motor. The stallGuard2 measurement value changes linearly over a wide range of load, velocity, and current settings. At maximum motor load, the value reaches zero or is near zero. This is the most energy-efficient point of operation for the motor.



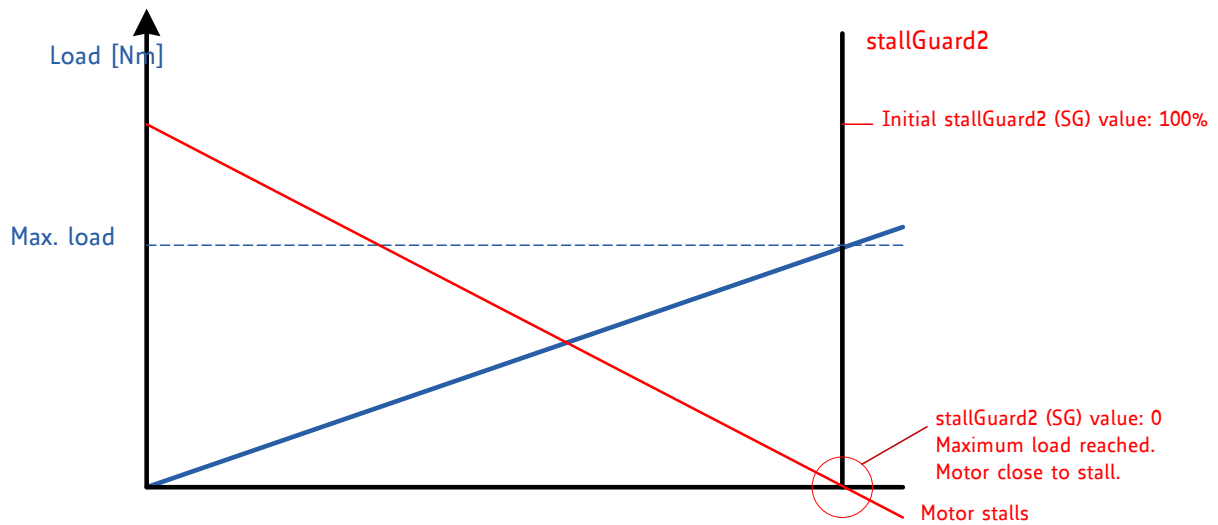

Figure 2: stallGuard2 Load Measurement as a Function of Load

1.4.2 coolStep

coolStep is a load-adaptive automatic current scaling based on the load measurement via stallGuard2 adapting the required current to the load. Energy consumption can be reduced by as much as 75%. coolStep allows substantial energy savings, especially for motors which see varying loads or operate at a high duty cycle. Because a stepper motor application needs to work with a torque reserve of 30% to 50%, even a constant-load application allows significant energy savings because coolStep automatically enables torque reserve when required. Reducing power consumption keeps the system cooler, increases motor life, and allows cost reduction.

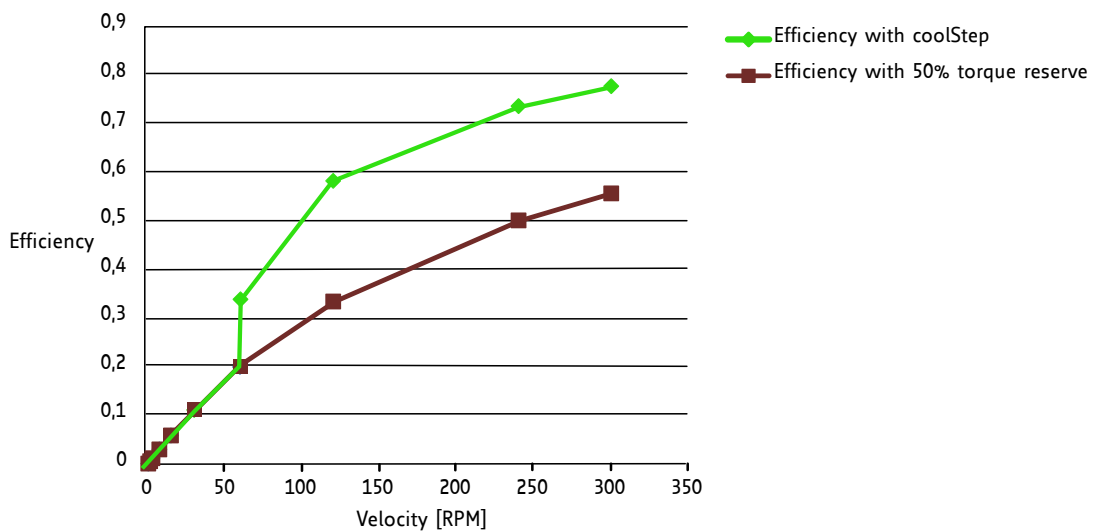

Figure 3: Energy Efficiency Example with coolStep



2 Communication

2.1 Reference Model

The application layer comprises a concept to configure and communicate real-time-data as well as the mechanisms for synchronization between devices. The functionality which the application layer offers to an application is logically divided over different service data objects (SDO) in the application layer. A service object offers a specific functionality and all the related services.

Applications interact by invoking services of a service object in the application layer. To realize these services this object exchanges data via the CAN Network with peer service object(s) using a protocol.

The application and the application layer interact with service primitives.

Service Primitives	
Primitive	Definition
Request	Issued by the application to the application layer to request a service.
Indication	Issued by the application layer to the application to report an internal event detected by the application layer or indicate that a service is requested.
Response	Issued by the application to the application layer to respond to a previous received indication.
Confirmation	Issued by the application layer to the application to report the result of a previously issued request.

Table 2: Service Primitives

A service type defines the primitives that are exchanged between the application layer and the cooperating applications for a particular service of a service object. Unconfirmed and confirmed services are collectively called remote services.

Service Types	
Type	Definition
Local service	Involves only the local service object. The application issues a request to its local service object that executes the requested service without communicating with peer service object(s).
Unconfirmed service	Involves one or more peer service objects. The application issues a request to its local service object. This request is transferred to the peer service object(s) that each passes it to their application as an indication. The result is not confirmed back.
Confirmed service	Can involve only one peer service object. The application issues a request to its local service object. This request is transferred to the peer service object that passes it to the other application as an indication. The other application issues a response that is transferred to the originating service object that passes it as a confirmation to the requesting application.
Provider initiated service	Involves only the local service object. The service object (being the service provider) detects an event not solicited by a requested service. This event is then indicated to the application.

Table 3: Service Types



2.2 NMT State Machine

The finite state machine (FSM) or simply state machine is a model of behavior composed of a finite number of states, transitions between those states, and actions. It shows which way the logic runs when certain conditions are met.

Starting and resetting the device is controlled via the state machine. The NMT state machine consists of the states shown in figure 4.

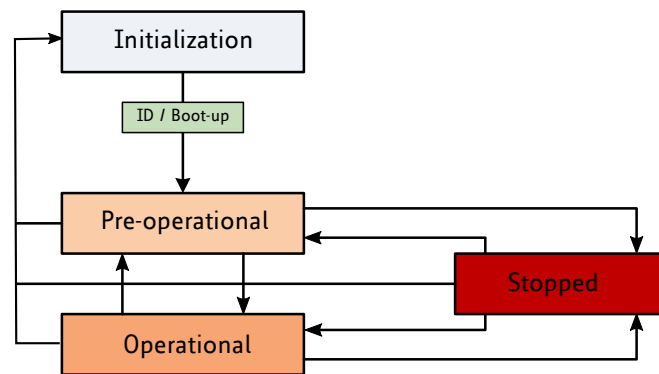

Figure 4: NMT State Machine

After power-on or reset the device enters the Initialization state. After the device initialization is finished, the device automatically transits to the **Pre-operational** state and indicates this state transition by sending the boot-up message. This way the device indicates that it is ready to work. A device that stays in Pre-operational state may start to transmit SYNC-, time stamp- or heartbeat message. In contrast to the PDO communication that is disabled in this state, the device can communicate via SDO.

The PDO communication is only possible within the **Operational** state. During Operational state the device can use all supported communication objects.

A device that was switched to the **Stopped** state only reacts on received NMT commands. In addition the device indicates the current NMT state by supporting the error control protocol during Stopped state.

The transitions between states are made by issuing a network management (NMT) communication object to the device. The NMT protocols are used to generate state machine change commands (e.g. to start and stop the device), detect remote device boot-ups and error conditions.

The Heartbeat message of a CANopen device contains the device status of the NMT state machine and is sent cyclically by the CANopen device.

The NMT state machine (or DS301 state machine) is not to be confused with the DS402 state machine. There is only one NMT state machine for the entire device, but for each motor there is a DS402 state machine which controls the motor. There are no links between these state machines, with one exception: When the NMT state machine is being switched to the stopped state, all DS402 state machines that are in OPERATION_ENABLED state will be switch to FAULT state.



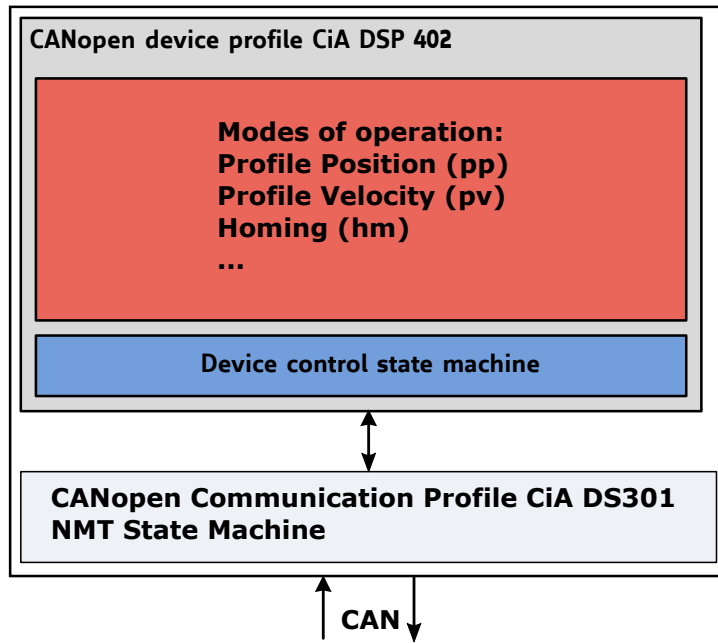

Figure 5: Communication Architecture



2.3 Device Model

A CANopen device mainly consists of the following parts:

- *Communication*: This function unit provides the communication objects and the appropriate functionality to transport data items via the underlying network structure.
- *Object dictionary*: The object dictionary is a collection of all the data items which have an influence on the behavior of the application objects, the communication objects and the state machine used on this device.
- *Application*: The application comprises the functionality of the device with respect to the interaction with the process environment.

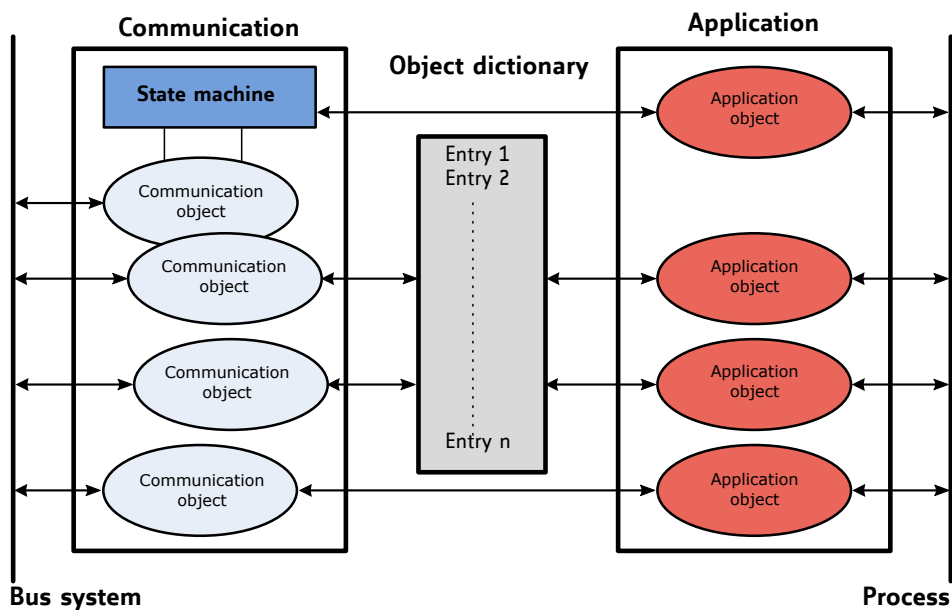

Figure 6: Device Model



2.4 Object Dictionary

The most important part of a device profile is the object dictionary description. The object dictionary is essentially a grouping of objects accessible via the network in an ordered pre-defined fashion. Each object within the dictionary is addressed using a 16-bit index. The overall layout of the standard object dictionary is shown in table 4:

Object Dictionary	
Index	Object
0000 _h	Not used.
0001 _h – 001F _h	Static data types.
0020 _h – 003F _h	Complex data types.
0040 _h – 005F _h	Manufacturer specific complex data types.
0060 _h – 007F _h	Device profile specific static data types.
0080 _h – 009F _h	Device profile specific complex data types.
00A0 _h – 0FFF _h	Reserved for further use.
1000 _h – 1FFF _h	Communication profile area.
2000 _h – 5FFF _h	Manufacturer specific profile area.
6000 _h – 9FFF _h	Standardized device profile area.
A000 _h – BFFF _h	Standardized interface profile area.
C000 _h – FFFF _h	Reserved for further use.

Table 4: Object Dictionary

The communication profile area at indices 1000_h through 1FFF_h contains the communication specific parameters for the CAN network. These entries are common to all devices.

The manufacturer segment at indices 2000_h through 5FFF_h contains manufacturer specific objects. These objects control the special features of the Trinamic TMCM-3212 motion control device.

The standardized device profile area at indices 6000_h through 9FFF_h contains all data objects common to a class of devices that can be read or written via the network. They describe the device parameters and the device functionality of the device profile.

2.4.1 Object Indices on Multi-Axis Modules

On a multi-axis module like the TMCM-3212 each object in the manufacturer area and each object in the profile specific area is available for each motor. In this manual, only the object indices for motor #0 are shown. The objects for the other motors can be accessed by adding offsets to the object indices:

- Add an offset of $motor_number \cdot 200_h$ to the index of a manufacturer specific object to get its index for other motors.
- Add an offset of $motor_number \cdot 800_h$ to the index of a profile specific object to get its index for other motors.

For example, the control word for motor #1 would be 6840_h (instead of 6040_h for motor #0), and the microstep resolution of motor #1 would be 2200_h for motor #1 (instead of 2000_h for motor #0).



Multi-Axis Object Indices		
Motor	Manufacturer area	Profile area
Motor #0	2000 _h - 21FF _h	6000 _h - 67FF _h
Motor #1	2200 _h - 23FF _h	6800 _h - 6FFF _h
Motor #2	2400 _h - 25FF _h	7000 _h - 77FF _h

Table 5: Multi-Axis Object Indices



3 Communication area

The communication area contains all objects that define the communication parameters of the CANopen device according to the DS301 standard.

3.1 Detailed object specifications

3.1.1 Object 1000_h: Device Type

This object contains information about the device type. The object 1000_h describes the type of device and its functionality. It is composed of a 16-bit field which describes the device profile that is used and a second 16-bit field which provides additional information about optional functionality of the device.

Object Description			
Index	Name	Object Type	Data Type
1000 _h	Device type	Variable	UNSIGNED32

Table 6: Object Description (1000_h)

Entry Description				
Sub-index	Access	PDO Mapping	Value Range	Default Value
0	ro	no	UNSIGNED32	FFFC0192 _h

Table 7: Entry Description (1000_h)

3.1.2 Object 1001_h: Error Register

This object contains information about the device type. The object 1000_h describes the type of device and its functionality. It is composed of a 16-bit field which describes the device profile that is used and a second 16-bit field which provides additional information about optional functionality of the device.

Object Description			
Index	Name	Object Type	Data Type
1001 _h	Error register	Variable	UNSIGNED8

Table 8: Object Description (1001_h)

Entry Description				
Sub-index	Access	PDO Mapping	Value Range	Default Value
0	ro	no	UNSIGNED8	0

Table 9: Entry Description (1001_h)



Error Register Bits	
Bit	Definition
0	Generic error
1	Current
2	Voltage
3	Temperature
4	Communication error
5	Device profile specific
6	Reserved (always 0)
7	Manufacturer specific

Table 10: Error Register Bits

3.1.3 Object 1005_h: COB-ID SYNC Message

This object defines the COB-ID of the synchronization object (SYNC). Further, it defines whether the module generates the SYNC.

Value Definition		
Bit	Name	Definition
30	Generate	0: Device does not generate SYNC message 1: Device generates SYNC message
29	Frame	Not supported, always set to 0.
28...11	29 bit ID	Not supported, always set to 0.
10...0	11 bit ID	11 bit COB-ID.

Table 11: Value Definition (1005_h)

Object Description			
Index	Name	Object Type	Data Type
1005 _h	COB-ID SYNC message	Variable	UNSIGNED32

Table 12: Object Description (1005_h)

Entry Description				
Sub-index	Access	PDO Mapping	Value Range	Default Value
0	rw	no	UNSIGNED32	80 _h

Table 13: Entry Description (1005_h)

3.1.4 Object 1008_h: Manufacturer Device Name

This object contains the manufacturer device name.

Object Description			
Index	Name	Object Type	Data Type
1008 _h	Manufacturer Device Name	Variable	Visible String

Table 14: Object Description (1008_h)

Entry Description				
Sub-index	Access	PDO Mapping	Value Range	Default Value
0	ro	no	—	TMCM-3212

Table 15: Entry Description (1008_h)

3.1.5 Object 1009_h: Manufacturer Hardware Version

This object contains the hardware version description.

Object Description			
Index	Name	Object Type	Data Type
1009 _h	Manufacturer Hardware Version	Variable	Visible String

Table 16: Object Description (1009_h)

Entry Description				
Sub-index	Access	PDO Mapping	Value Range	Default Value
0	ro	no	—	Depends on device, e.g. 1.0.

Table 17: Entry Description (1009_h)

3.1.6 Object 100A_h: Manufacturer Software Version

This object contains the software version description.

Object Description			
Index	Name	Object Type	Data Type
100A _h	Manufacturer Software Version	Variable	Visible String

Table 18: Object Description (100A_h)

Entry Description				
Sub-index	Access	PDO Mapping	Value Range	Default Value
0	ro	no	—	Depends on device, e.g. 1.0.

Table 19: Entry Description (100A_h)

3.1.7 Object 100C_h: Guard Time

The objects at index 100C_h and 100D_h shall indicate the configured guard time respectively the life time factor. The life time factor multiplied with the guard time gives the life time for the life guarding protocol.

Object Description			
Index	Name	Object Type	Data Type
100C _h	Guard Time	Variable	UNSIGNED16

Table 20: Object Description (100C_h)



Entry Description				
Sub-index	Access	PDO Mapping	Value Range	Default Value
0	rw	no	UNSIGNED16	0

Table 21: Entry Description (100C_h)

3.1.8 Object 100D_h: Life Time Factor

The life time factor multiplied with the guard time gives the life time for the life guarding protocol.

Object Description			
Index	Name	Object Type	Data Type
100D _h	Life Time Factor	Variable	UNSIGNED8

Table 22: Object Description (100D_h)

Entry Description				
Sub-index	Access	PDO Mapping	Value Range	Default Value
0	rw	no	UNSIGNED8	0

Table 23: Entry Description (100D_h)

3.1.9 Object 1010_h: Store Parameters

This object supports the saving of parameters in non volatile memory. By read access the device provides information about its saving capabilities.

This command can only be carried out if the module is in ready to switch on mode.

There are several parameter groups:

- Sub-index 0_h: contains the largest sub-index that is supported.
- Sub-index 1_h: saves all parameters.
- Sub-index 2_h: saves communication parameters 100C_h, 100D_h, 1015_h, 1017_h, and 1029_h.
- Sub-index 3_h: saves device profile parameters.
- Sub-index 4_h: saves motor 0 parameters.
- Sub-index 5_h: saves motor 1 parameters.
- Sub-index 6_h: saves motor 2 parameters.

In order to avoid storage of parameters by mistake, storage is only executed when a specific signature is written to the appropriate sub-Index. This signature is "save" (65766173_h, see also table 24).

Save Signature			
e	v	a	s
65 _h	76 _h	61 _h	73 _h

Table 24: Save Signature



On reception of the correct signature in the appropriate sub-index the device stores the parameter and then confirms the SDO transmission (initiate download response). If the storing failed, the device responds with an abort SDO transfer (abort code: 06060000_h). If a wrong signature is written, the device refuses to store and responds with abort SDO transfer (abort code: 0800002x_h).

On read access, each sub-index provides information if it is possible to store the parameter group. It reads 1 if yes and 0 if no.

Object Description			
Index	Name	Object Type	Data Type
1010 _h	Store Parameters	Array	UNSIGNED32

Table 25: Object Description (1010_h)

Entry Description					
Sub-index	Description	Access	PDO Mapping	Value Range	Default Value
01h	Save all parameters	rw	no	UNSIGNED32	—
02h	Save communication parameters	rw	no	UNSIGNED32	—
03h	Save device profile parameters	rw	no	UNSIGNED32	—
04h	Save motor axis 0 parameters	rw	no	UNSIGNED32	—
04h	Save motor axis 1 parameters	rw	no	UNSIGNED32	—
04h	Save motor axis 2 parameters	rw	no	UNSIGNED32	—

Table 26: Entry Description (1010_h)

3.1.10 Object 1011_h: Restore Parameters

With this object the default values of parameters according to the communication or device profile are restored. By read access the device provides information about its capabilities to restore these values.

This command can only be carried out if the module is in ready to switch on mode.

There are several parameter groups:

- Sub-index 0_h: contains the largest sub-index that is supported.
- Sub-index 1_h: restores all parameters.
- Sub-index 2_h: restores communication parameters 100C_h, 100D_h, 1015_h, 1017_h, and 1029_h.
- Sub-index 3_h: restores device profile parameters.
- Sub-index 4_h: restores motor 0 parameters.
- Sub-index 5_h: restores motor 1 parameters.
- Sub-index 6_h: restores motor 2 parameters.

In order to avoid restoring the parameters by mistake, restoring is only executed when a specific signature is written to the appropriate sub-Index. This signature is "load" (64616F6C_h, see also table 27).



Load Signature			
d	a	o	l
64 _h	61 _h	6F _h	6C _h

Table 27: Load Signature

On reception of the correct signature in the appropriate sub-index the device restores the parameter and then confirms the SDO transmission (initiate download response). If the restoring failed, the device responds with an abort SDO transfer (abort code: 06060000_h). If a wrong signature is written, the device refuses to restore and responds with abort SDO transfer (abort code: 0800002x_h).

On read access, each sub-index provides information if it is possible to restore the parameter group. It reads 1 if yes and 0 if no.

After the default values have been restored they will become active after the next rest or power cycle of the TMCM-3212.

Object Description			
Index	Name	Object Type	Data Type
1011 _h	Restore parameters	Array	UNSIGNED32

Table 28: Object Description (1011_h)

Entry Description					
Sub-index	Description	Access	PDO Mapping	Value Range	Default Value
01h	Restore all parameters	rw	no	UNSIGNED32	—
02h	Restore communication parameters	rw	no	UNSIGNED32	—
03h	Restore device profile parameters	rw	no	UNSIGNED32	—
04h	Restore motor axis 0 parameters	rw	no	UNSIGNED32	—
04h	Restore motor axis 1 parameters	rw	no	UNSIGNED32	—
04h	Restore motor axis 2 parameters	rw	no	UNSIGNED32	—

Table 29: Entry Description (1011_h)

3.1.11 Object 1014_h: COB-ID Emergency Object

This object defines the COB-ID of the emergency object (EMCY).

Object Description			
Index	Name	Object Type	Data Type
1014 _h	COB-ID emergency object	Variable	UNSIGNED32

Table 30: Object Description (1014_h)

Entry Description				
Sub-index	Access	PDO Mapping	Value Range	Default Value
0	rw	no	UNSIGNED32	80 _h + Node ID

Table 31: Entry Description (1014_h)



3.1.12 Object 1015_h: Inhibit Time EMCY

The inhibit time for the EMCY message can be adjusted via this entry. The time has to be a multiple of 100µs.

Object Description			
Index	Name	Object Type	Data Type
1015 _h	COB-ID emergency object	Variable	UNSIGNED16

Table 32: Object Description (1015_h)

Entry Description				
Sub-index	Access	PDO Mapping	Value Range	Default Value
0	rw	no	UNSIGNED16	0

Table 33: Entry Description (1015_h)

3.1.13 Object 1016_h: Consumer Heartbeat Time

The consumer heartbeat time defines the expected heartbeat cycle time and thus has to be higher than the corresponding producer heartbeat time configured on the module producing this heartbeat. The monitoring starts after the reception of the first heartbeat. If the consumer heartbeat time is 0 the corresponding entry is not used. The time has to be a multiple of 1ms.

Value Definition		
Bits	Name	Definition
31...24	Reserved	—
23...16	Node ID	Heartbeat Producer Node ID
15...0	Heartbeat time	Time in 1ms

Table 34: Value Definition (1016_h)

Object Description			
Index	Name	Object Type	Data Type
1016 _h	Consumer heartbeat time	Variable	UNSIGNED16

Table 35: Object Description (1016_h)

Entry Description				
Sub-index	Access	PDO Mapping	Value Range	Default Value
0	rw	no	UNSIGNED16	0

Table 36: Entry Description (1016_h)

3.1.14 Object 1017_h: Producer Heartbeat Time

The producer heartbeat time defines the cycle time of the heartbeat. The producer heartbeat time is 0 if it is not used. The time has to be a multiple of 1ms.



Object Description			
Index	Name	Object Type	Data Type
1017 _h	Producer heartbeat time	Variable	UNSIGNED16

Table 37: Object Description (1017_h)

Entry Description				
Sub-index	Access	PDO Mapping	Value Range	Default Value
0	rw	no	UNSIGNED16	0

Table 38: Entry Description (1017_h)

3.1.15 Object 1018_h: Identity Object

The object 1018_h contains general information about the device:

- The vendor ID (sub-index 01_h) contains a unique value allocated to each manufacturer. The vendor ID of Trinamic is 286_h.
- The manufacturer specific product code (sub-index 2_h) identifies a specific device version.
- The manufacturer specific revision number (sub-index 3_h) consists of a major revision number and a minor revision number.

Object Description			
Index	Name	Object Type	Data Type
1018 _h	Identity object	Record	Identity

Table 39: Object Description (1018_h)

Entry Description					
Sub-index	Description	Access	PDO Mapping	Value Range	Default Value
00 _h	Number of entries	ro	no	0...3	3
01 _h	Vendor ID	ro	no	UNSIGNED32	0286 _h
02 _h	Product code	ro	no	UNSIGNED32	3212
03 _h	Revision number	ro	no	UNSIGNED32	e.g. 20003 _h for version 2.3

Table 40: Entry Description (1018_h)

3.1.16 Object 1029_h: Error Behaviour

If a device failure is detected in operational state, the device can be configured to enter alternatively the stopped state or remain in the current state in case of a device failure. Device failures include the following errors:

- Communication error
- Application error

Object Description			
Index	Name	Object Type	Data Type
1029 _h	Error behaviour	Array	UNSIGNED8

Table 41: Object Description (1029_h)

Entry Description					
Sub-index	Description	Access	PDO Mapping	Value Range	Default Value
00 _h	Number of error classes	ro	no	—	2
01 _h	Communication error	rw	no	UNSIGNED8	0 (enter stopped state)
02 _h	Application error	rw	no	UNSIGNED8	1 (remain in current state)

Table 42: Entry Description (1029_h)

3.1.17 Objects 1400_h – 1403_h: Receive PDO Communication Parameter

This object contains the communication parameters for the RPDOs which the device is able to receive. The sub-index 00_h contains the number of valid entries within the communication record. Its value normally is 2, as this object consists of two other entries.

Sub-index 01_h contains the COB-ID used by this PDO (in bits 10...0). Bit 30 (RTR bit) defines if this PDO uses RTRs. As RTRs are not supported for PDOs by this CANopen implementation, this bit must always be set in order to turn off RTR support for this PDO. Bit 31 defines if this PDO is active or not. If this bit is set, the PDO is inactive, and if this bit is clear, the PDO is active. Before making any changes to a PDO definition, set this bit to inactivate the PDO.

Sub-Index 02_h contains the transmission type of the RPDO. This can be FF_h or FE_h for event-driven, or 00_h for synchronous.

The RPDOs defined by objects 1400_h – 1403_h (RPDO 1...3) are normally used for motor #0. For the other motors, the following RPDOs are used:

- RPDO 65...68 (objects 1440_h – 1443_h) for motor #1.
- RPDO 129...132 (objects 1480_h – 1483_h) for motor #2.

Object Description			
Index	Name	Object Type	Data Type
1400 _h – 1403 _h	Receive PDO parameter	RECORD	RPDO CommPar
1400 _h	RPDO 1	RECORD	RPDO CommPar
1401 _h	RPDO 2	RECORD	RPDO CommPar
1402 _h	RPDO 3	RECORD	RPDO CommPar
1403 _h	RPDO 4	RECORD	RPDO CommPar

Table 43: Object Description (1400_h)

Entry Description				
Sub-index	Description	Access	Value Range	Default Value
00 _h	Largest sub-index supported	ro	2	2
01 _h	COB-ID used by PDO	rw	UNSIGNED32	Index 1400 _h : 200 _h + Node-ID Index 1401 _h : 300 _h + Node-ID Index 1402 _h : 400 _h + Node-ID Index 1403 _h : 500 _h + Node-ID
02 _h	Transmission type	rw	UNSIGNED8	Index 1400 _h : FF _h Index 1401 _h : FF _h Index 1402 _h : FF _h Index 1403 _h : FE _h

Table 44: Entry Description (1400_h)

3.1.18 Objects 1600_h – 1603_h: Receive PDO Mapping Parameter

These objects contain the mapping parameters for the RPDOs the device is able to receive. The sub-index 00_h contains the number of valid entries within the mapping record. This number of entries is also the number of the application variables which shall be received with the corresponding RPDO. The sub-indices from 01_h to the number of entries contain the information about the mapped application variables. These entries describe the PDO contents by their index, sub-index and length.

The RPDOs defined by objects 1600_h – 1603_h (RPDO 1... 3) are normally used for motor #0. For the other motors, the following RPDOs are used:

- RPDO 65... 68 (objects 1640_h – 1643_h) for motor #1.
- RPDO 129... 132 (objects 1680_h – 1683_h) for motor #2.

Object Description			
Index	Name	Object Type	Data Type
1600 _h – 1603 _h	Receive PDO mapping parameter	RECORD	PDO Mapping
1600 _h	RPDO 1	RECORD	PDO Mapping
1601 _h	RPDO 2	RECORD	PDO Mapping
1602 _h	RPDO 3	RECORD	PDO Mapping
1603 _h	RPDO 4	RECORD	PDO Mapping

Table 45: Object Description (1600_h)

Entry Description				
Sub-index	Description	Access	Value Range	Default Value
00 _h	Number of mapped application objects in PDO	rw	0...3	Index 1600 _h : 1 Index 1601 _h : 2 Index 1602 _h : 2 Index 1603 _h : 2
01 _h	Mapping entry 1	rw	UNSIGNED32	Index 1600 _h : 60400010 _h Index 1601 _h : 60400010 _h Index 1602 _h : 60400010 _h Index 1603 _h : 60400010 _h
02 _h	Mapping entry 2	rw	UNSIGNED32	Index 1600 _h : 0 Index 1601 _h : 60600008 _h Index 1602 _h : 607A0020 _h Index 1603 _h : 60FF0020 _h
03 _h	Mapping entry 3	rw	UNSIGNED32	Index 1600 _h : 0 _h Index 1601 _h : 0 _h Index 1602 _h : 0 _h Index 1603 _h : 0 _h

Table 46: Entry Description (1600_h)

Before making changes to PDO definitions, first mark the PDO as inactive by setting bit 31 of its COB-ID (see section 3.1.17). Then, set its number of mapped PDO entries to zero (sub-index 0 of the appropriate PDO mapping object). Now, the mappings themselves can be changed. After that, set the number of map objects to the desired value, and finally activate the PDO by clearing bit 31 of its COB-ID.

3.1.19 Objects 1800_h – 1803_h: Transmit PDO Communication Parameter

This object contains the communication parameters for the TPDOs which the device is able to transmit. The sub-index 00_h contains the number of valid entries within the communication record. Its value normally is 5, as this object consists of five other entries.

Sub-index 01_h contains the COB-ID used by this PDO (in bits 10...0). Bit 30 (RTR bit) defines if this PDO uses RTRs. As RTRs are not supported for PDOs by this CANopen implementation, this bit must always be set in order to turn off RTR support for this PDO. Bit 31 defines if this PDO is active or not. If this bit is set, the PDO is inactive, and if this bit is clear, the PDO is active. Before making any changes to a PDO definition, set this bit to inactivate the PDO.

Sub-index 02_h contains the transmission type of the RPDO. This can be FF_h or FE_h for event-driven, or 00_h or 01_h for synchronous.

Sub-index 03_h contains the inhibit time, given in milliseconds. After a TPDO has been sent, it will not be sent again before the inhibit time has elapsed.

Sub-index 04_h is not used.

Sub-index 05_h contains the event timer value in milliseconds. When this is set to a value greater than 0 the TPDO will be sent repeatedly each time the event timer has elapsed. For example, when this value is set to 250, the TPDO will be sent every 250ms.

The TPDOs defined by objects 1800_h – 1803_h (TPDO 1...3) are normally used for motor #0. For the other motors, the following TPDOs are used:

- TPDO 65...68 (objects 1840_h – 1843_h) for motor #1.



- TPDO 129...132 (objects 1880_h – 1883_h) for motor #2.

Object Description			
Index	Name	Object Type	Data Type
1800 _h – 1803 _h	Transmit PDO communication parameter	RECORD	TPDO CommPar
1800 _h	TPDO 1	RECORD	TPDO CommPar
1801 _h	TPDO 2	RECORD	TPDO CommPar
1802 _h	TPDO 3	RECORD	TPDO CommPar
1803 _h	TPDO 4	RECORD	TPDO CommPar

Table 47: Object Description (1800_h)

Entry Description				
Sub-index	Description	Access	Value Range	Default Value
00 _h	Largest sub-index supported	ro	5	5
01 _h	COB-ID	rw	UNSIGNED32	Index 1800 _h : 180 _h + Node-ID Index 1801 _h : 280 _h + Node-ID Index 1802 _h : 380 _h + Node-ID Index 1803 _h : 480 _h + Node-ID
02 _h	Transmission type	rw	UNSIGNED8	Index 1800 _h : FF _h Index 1801 _h : FF _h Index 1802 _h : 01 _h Index 1803 _h : 01 _h
03 _h	Inhibit time	rw	UNSIGNED16	0
04 _h	Compatibility entry	ro	UNSIGNED8	0
05 _h	Event timer	rw	UNSIGNED16	0

Table 48: Entry Description (1800_h)

3.1.20 Objects 1A00_h – 1A03_h: Transmit PDO Mapping Parameter

These objects contain the mapping parameters for the TPDOs the device is able to transmit. The sub-index 00_h contains the number of valid entries within the mapping record. This number of entries is also the number of the application variables which shall be transmitted with the corresponding TPDO. The sub-indices from 01_h to the number of entries contain the information about the mapped application variables. These entries describe the PDO contents by their index, sub-index and length.

The TPDOs defined by objects 1A00_h – 1A03_h (TPDO 1...3) are normally used for motor #0. For the other motors, the following TPDOs are used:

- TPDO 65...68 (objects 1A40_h – 1A43_h) for motor #1.
- TPDO 129...132 (objects 1A80_h – 1A83_h) for motor #2.



Object Description			
Index	Name	Object Type	Data Type
1A00 _h – 1A03 _h	Transmit PDO mapping parameter	RECORD	PDO Mapping
1A00 _h	TPDO 1	RECORD	PDO Mapping
1A01 _h	TPDO 2	RECORD	PDO Mapping
1A02 _h	TPDO 3	RECORD	PDO Mapping
1A03 _h	TPDO 4	RECORD	PDO Mapping

Table 49: Object Description (1A00_h)

Entry Description				
Sub-index	Description	Access	Value Range	Default Value
00 _h	Number of mapped application objects in PDO	rw	0...3	Index 1A00 _h : 1 Index 1A01 _h : 2 Index 1A02 _h : 2 Index 1A03 _h : 2
01 _h	Mapping entry 1	rw	UNSIGNED32	Index 1A00 _h : 60410010 _h Index 1A01 _h : 60410010 _h Index 1A02 _h : 60410010 _h Index 1A03 _h : 60410010 _h
02 _h	Mapping entry 2	rw	UNSIGNED32	Index 1A00 _h : 0 Index 1A01 _h : 60610008 _h Index 1A02 _h : 60640020 _h Index 1A03 _h : 606C0020 _h
03 _h	Mapping entry 3	rw	UNSIGNED32	Index 1A00 _h : 0 _h Index 1A01 _h : 0 _h Index 1A02 _h : 0 _h Index 1A03 _h : 0 _h

Table 50: Entry Description (1A00_h)

Before making changes to PDO definitions, first mark the PDO as inactive by setting bit 31 of its COB-ID (see section 3.1.19). Then, set its number of mapped PDO entries to zero (sub-index 0 of the appropriate PDO mapping object). Now, the mappings themselves can be changed. After that, set the number of mapped objects to the desired value, and finally activate the PDO by clearing bit 31 of its COB-ID.



4 Manufacturer specific area

The manufacturer segment contains manufacturer specific objects. These objects control the special features of the Trinamic Motion Control device TMCM-3212.

This section of the manual only shows the object indices for motor #0. Of course the same objects are also available for the other motors. For the other motors, add an offset of $motor_number \cdot 200_h$ to the object index. So for example the microstep resolution (object 2000_h for motor #0) can be accessed as object 2200_h for motor #1 and as object 2400_h for motor #2. Please see also section 2.4.1.

Multi-axis Object Indices	
Motor	Object Index Range
Motor #0	$2000_h - 21FF_h$
Motor #1	$2200_h - 23FF_h$
Motor #2	$2400_h - 25FF_h$

Table 51: Multi-axis Object Indices (Manufacturer specific Area)

4.1 Objects related to coolStep

Figure 7 shows an overview of the coolStep related objects for motor #0. Please bear in mind that the figure only shows one example for a drive. There are objects which concern the configuration of the current. Other objects are for velocity regulation and for time adjustment. The coolStep feature is sometimes also called smartEnergy.

The following adjustments have to be made:

- Thresholds for current and velocity have to be identified and set.
- The stallGuard2 feature has to be adjusted and enabled.
- The reduction or increasing of the current in the coolStep area (depending on the load) has to be configured.



coolStep™ adjustment points and thresholds

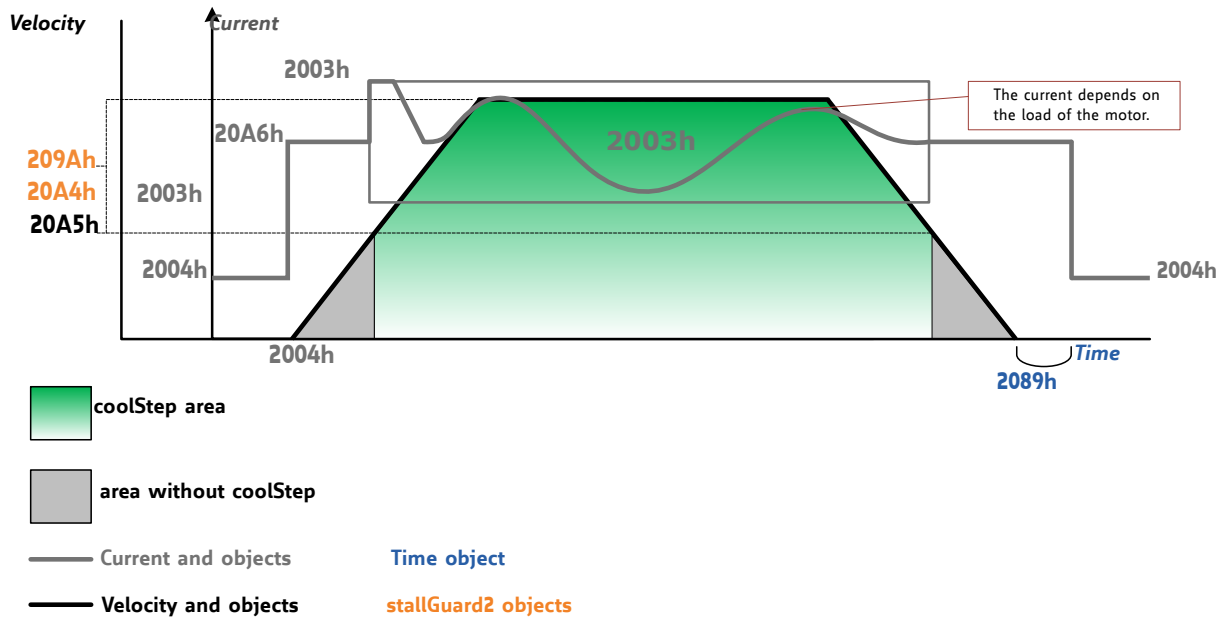

Figure 7: coolStep Adjustment Points and Thresholds



coolStep Adjustment Objects		
Object	Name	Description
2003 _h	Absolute maximum current	The maximum value is 255. This value means 100% of the maximum current of the module. The current adjustment is within the range 0...255 and can be adjusted in 32 steps (0...255 divided by eight; step 0 = 0...7, step 1 = 8...15 and so on). The most important motor setting, since too high values might cause motor damage!
2004 _h	Standby current	The current limit two seconds after the motor has stopped.
2098 _h	smartEnergy current minimum	Sets the lower motor current limit for coolStep operation by scaling the run current (object 2003 _h) value. This can be: 0: for 1/2 of the run current 1: for 1/4 of the run current
2099 _h	smartEnergy current down step	Sets the speed of current decrement when the stallGuard reading is above the upper threshold. 0: slow decrement 3: fast decrement
209B _h	smartEnergy current up step	Sets the current increment step when the stallGuard below the lower threshold. 0: slow increment 3: fast increment / fast reaction to rising load
209A _h	smartEnergy hysteresis	Sets the distance between the lower and the upper threshold for stallGuard2 reading. Above the upper threshold the motor current becomes decreased.
20A4 _h	Stop on stall	Below this speed the motor will not be stopped. Above this speed the motor will stop in case stallGuard2 load value reaches zero.
20A5 _h	smartEnergy threshold speed.	Above this speed coolStep becomes enabled.
2089 _h	Standby delay	Standstill period before the current is changed down to standby current. The standard value is 200 which is 2 seconds.

Table 52: coolStep related Objects



4.2 Detailed object specifications

4.2.1 Object 2000_h: Microstep resolution

This object sets the microstep resolution of the drive. A value of 8 selects 256 (2⁸) microsteps per full step.

Object Description			
Index	Name	Object Type	Data Type
2000 _h	Microstep Resolution	Variable	UNSIGNED8

Table 53: Object Description (2000_h)

Entry Description				
Sub-index	Access	PDO Mapping	Value Range	Default Value
0	rw	no	0...8	8

Table 54: Entry Description (2000_h)

4.2.2 Object 2001_h: Microstep resolution

This object sets the fullstep resolution of the motor connected to the drive. Its default value is 200 because most motors are 1.8° motors.

Object Description			
Index	Name	Object Type	Data Type
2001 _h	Motor full step resolution	Variable	UNSIGNED16

Table 55: Object Description (2001_h)

Entry Description				
Sub-index	Access	PDO Mapping	Value Range	Default Value
0	rw	no	0...65535	200

Table 56: Entry Description (2001_h)

4.2.3 Object 2002_h: Brake delay times

With this object the delay times for applying and releasing an (optional) brake can be defined. Please see also object 200Ah for an additional delay between enabling the power stage and releasing the brake. Both times are given in ms.



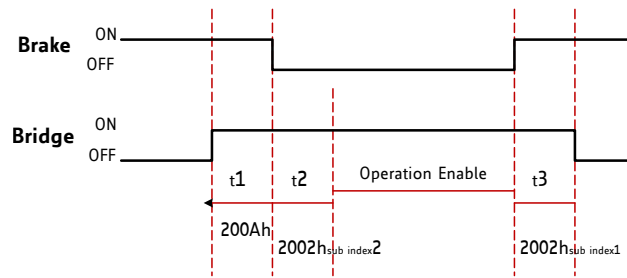

Figure 8: Brake Output Timing

Object Description			
Index	Name	Object Type	Data Type
2002 _h	Brake delay times	Array	UNSIGNED16

Table 57: Object Description (2002_h)

Entry Description					
Sub-index	Description	Access	PDO Mapping	Value Range	Default Value
1	Time between applying brake / disabling power stage	rw	no	0..65535	0
2	Time between releasing brake / switching the state machine to operational	rw	no	0..65535	0

Table 58: Entry Description (2002_h)

4.2.4 Object 2003_h: Maximum current

This object defines the current used when the motor is moving. A value of 255 means 100% of the maximum current of the drive.

Object Description			
Index	Name	Object Type	Data Type
2003 _h	Maximum current	Variable	UNSIGNED8

Table 59: Object Description (2003_h)

Entry Description				
Sub-index	Access	PDO Mapping	Value Range	Default Value
0	rw	no	0...255	128

Table 60: Entry Description (2003_h)

4.2.5 Object 2004_h: Standby current

This object defines the current used when the motor is standing (two seconds after the last move). A value of 255 means 100% of the maximum current of the drive.



Object Description			
Index	Name	Object Type	Data Type
2004 _h	Maximum current	Variable	UNSIGNED8

Table 61: Object Description (2004_h)

Entry Description				
Sub-index	Access	PDO Mapping	Value Range	Default Value
0	rw	no	0...255	8

Table 62: Entry Description (2004_h)

4.2.6 Object 2005_h: Limit switches

This object defines which limit switches are to be used. Bit 0 stands for the left and bit 1 stands for the right limit switch. If a bit is set, the corresponding limit switch will not be used. So this object has to be set to the value 3 if limit switches are not connected. The object can only be written when the drive is in the SWITCHED_ON_DISABLED state (but is always readable).

The limit switches can also be inverted using bit 2 and bit 3:

- Bit 2 inverts the left limit switch
- Bit 3 inverts the right limit switch

Object Description			
Index	Name	Object Type	Data Type
2005 _h	Limit switches	Variable	UNSIGNED32

Table 63: Object Description (2005_h)

Entry Description				
Sub-index	Access	PDO Mapping	Value Range	Default Value
0	rw	no	0...63	0

Table 64: Entry Description (2005_h)

Bit Definitions	
Bit	Definition
0	Left limit switch deactivated, if set.
1	Right limit switch deactivated, if set.
2	Left limit switch inverted, if set.
3	Right limit switch inverted, if set.
4	Home switch deactivated, if set.
5	Home switch inverted, if set.

Table 65: Bit Definitions (2005_h)

4.2.7 Object 200A_h: Enable drive delay time

This is an additional delay time (in milliseconds) between enabling the power stage and releasing the brake. It can be used to prevent the brake from being released too early (before the hold current in the



motor has been reached). Please see also object 4.2.3.

Object Description			
Index	Name	Object Type	Data Type
200A _h	Enable drive delay time	Variable	UNSIGNED16

Table 66: Object Description (200A_h)

Entry Description				
Sub-index	Access	PDO Mapping	Value Range	Default Value
0	rw	no	0...65535	0

Table 67: Entry Description (200A_h)

4.2.8 Object 200B_h: Encoder parameters

This object defines encoder parameters. These are the polarity of the encoder null channel, the direction of rotation (set it to 1 if the direction is reversed compared to the motor) and if the position is to be initialized with the encoder position. It is only writable in SWITCHED_ON_DISABLED state.

Object Description			
Index	Name	Object Type	Data Type
200B _h	Encoder parameters	Array	UNSIGNED8

Table 68: Object Description (200B_h)

Entry Description					
Sub-index	Description	Access	PDO Mapping	Value Range	Default Value
1	Null channel polarity	rw	no	0/1	0
2	Direction of rotation	rw	no	0/1	0
3	Initialize position	rw	no	0/1	1

Table 69: Entry Description (200B_h)

4.2.9 Object 200C_h: Brake current feed

This object configures how much current has to be fed into the brake to apply and to release it. 0 means 0 (the module). In most cases it is needed to feed current into the brake to release it. Setting both values to 0 disables the automatic brake control. This object is only writable in SWITCHED_ON_DISABLED state.

Object Description			
Index	Name	Object Type	Data Type
200C _h	Brake current feed	Array	UNSIGNED8

Table 70: Object Description (200C_h)



Entry Description					
Sub-index	Description	Access	PDO Mapping	Value Range	Default Value
1	Apply current	rw	no	0...255	0
2	Release current	rw	no	0...255	0

Table 71: Entry Description (200C_h)

4.2.10 Object 2010_h: Profile Start Velocity

This object contains the velocity with which a positioning ramp will be started.

Object Description			
Index	Name	Object Type	Data Type
2010 _h	Profile Start Velocity	Variable	UNSIGNED32

Table 72: Object Description (2010_h)

Entry Description				
Sub-index	Access	PDO Mapping	Value Range	Default Value
0	rw	no	0...268435455	0

Table 73: Entry Description (2010_h)

4.2.11 Object 2011_h: Profile A1

This object contains the acceleration value used for ramping up from the start velocity (object 2011_h, see section 4.2.10) to the velocity V1 (object (h)2012, see section 4.2.12).

Object Description			
Index	Name	Object Type	Data Type
2011 _h	Profile A1	Variable	UNSIGNED32

Table 74: Object Description (2011_h)

Entry Description				
Sub-index	Access	PDO Mapping	Value Range	Default Value
0	rw	no	0...16777215	0

Table 75: Entry Description (2011_h)

4.2.12 Object 2012_h: Profile V1

This object contains the velocity used for the first segment of a positioning ramp.

Object Description			
Index	Name	Object Type	Data Type
2012 _h	Profile V1	Variable	UNSIGNED32

Table 76: Object Description (2012_h)



Entry Description				
Sub-index	Access	PDO Mapping	Value Range	Default Value
0	rw	no	06777215	0

Table 77: Entry Description (2012_h)

4.2.13 Object 2013_h: Profile D1

This object contains the deceleration value used for decelerating from the maximum positioning velocity to the velocity V1 (object 2012_h, see section 4.2.12).

Object Description			
Index	Name	Object Type	Data Type
2013 _h	Profile D1	Variable	UNSIGNED32

Table 78: Object Description (2013_h)

Entry Description				
Sub-index	Access	PDO Mapping	Value Range	Default Value
0	rw	no	0...16777215	0

Table 79: Entry Description (2013_h)

4.2.14 Object 2089_h: Setting Delay

This object has to be used for setting a standstill period before the current is changed down to standby current.

Unit: 10msec

Object Description			
Index	Name	Object Type	Data Type
2089 _h	Setting Delay	Variable	UNSIGNED8

Table 80: Object Description (2089_h)

Entry Description				
Sub-index	Access	PDO Mapping	Value Range	Default Value
0	rw	no	0...255	200

Table 81: Entry Description (2089_h)

4.2.15 Object 208C_h: Velocity Dimension Index

With this object different units can be chosen:

- Writing 0 selects internal units.
- Writing 181 sets PPS for velocity and PPS/s for acceleration.



This can only be changed in SWITCHED_ON_DISABLED mode.

Object Description			
Index	Name	Object Type	Data Type
208C _h	Velocity Dimension Index	Variable	UNSIGNED8

Table 82: Object Description (208C_h)

Entry Description				
Sub-index	Access	PDO Mapping	Value Range	Default Value
0	rw	no	0/181	181

Table 83: Entry Description (208C_h)

4.2.16 Object 208E_h: Acceleration Dimension Index

With this object, the unit for acceleration can be read out. The unit can be set using object 208Ch. Object 208Eh reads 0 when internal units are selected and 179 when PPS/s is selected.

Object Description			
Index	Name	Object Type	Data Type
208E _h	Acceleration Dimension Index	Variable	UNSIGNED8

Table 84: Object Description (208E_h)

Entry Description				
Sub-index	Access	PDO Mapping	Value Range	Default Value
0	ro	no	0/179	179

Table 85: Entry Description (208E_h)

4.2.17 Object 2092_h: Chopper Blank Time

This object serves for selecting the comparator blank time. This time needs to safely cover the switching event and the duration of the ringing on the sense resistor. For low current drivers, a setting of 1 or 2 is good. For higher current applications a setting of 2 or 3 will be required.

Object Description			
Index	Name	Object Type	Data Type
2092 _h	Chopper Blank Time	Variable	UNSIGNED8

Table 86: Object Description (2092_h)

Entry Description				
Sub-index	Access	PDO Mapping	Value Range	Default Value
0	rw	no	0...3	2

Table 87: Entry Description (2092_h)



4.2.18 Object 2093_h: Chopper Mode

Select the chopper mode using this object:

- 0 – spreadCycle chopper
- 1 – classic constant off time chopper

Object Description			
Index	Name	Object Type	Data Type
2093 _h	Chopper Mode	Variable	UNSIGNED8

Table 88: Object Description (2093_h)

Entry Description				
Sub-index	Access	PDO Mapping	Value Range	Default Value
0	rw	no	0/1	0

Table 89: Entry Description (2093_h)

4.2.19 Object 2094_h: Chopper Hysteresis Decrement

This object serves for the hysteresis decrement setting. This setting determines the slope of the hysteresis during on time and during fast decay time.

- 0 – fast decrement
- 3 – very slow decrement

Object Description			
Index	Name	Object Type	Data Type
2094 _h	Chopper Hysteresis Decrement	Variable	UNSIGNED8

Table 90: Object Description (2094_h)

Entry Description				
Sub-index	Access	PDO Mapping	Value Range	Default Value
0	rw	no	0...3	0

Table 91: Entry Description (2094_h)

4.2.20 Object 2095_h: Chopper Hysteresis End

This object provides the setting of the hysteresis end value after a number of decrements. The decrement interval time is controlled by object 2094_h (section 4.2.19).

Possible values are:

- -3...-1 – negative hysteresis end setting
- 0 – zero hysteresis end setting
- 1...12 – positive hysteresis end setting



Object Description			
Index	Name	Object Type	Data Type
2095 _h	Chopper Hysteresis End	Variable	SIGNED8

Table 92: Object Description (2095_h)

Entry Description				
Sub-index	Access	PDO Mapping	Value Range	Default Value
0	rw	no	-3...12	0

Table 93: Entry Description (2095_h)

4.2.21 Object 2096_h: Chopper Hysteresis Start

This object provides the hysteresis start setting. Please notice that this value is an offset to the hysteresis end value.

Object Description			
Index	Name	Object Type	Data Type
2096 _h	Chopper Hysteresis Start	Variable	UNSIGNED8

Table 94: Object Description (2096_h)

Entry Description				
Sub-index	Access	PDO Mapping	Value Range	Default Value
0	rw	no	0...8	3

Table 95: Entry Description (2096_h)

4.2.22 Object 2097_h: Chopper Off Time

The off time setting controls the minimum chopper frequency. Under normal circumstances, an off time within the range of 5µs to 20µs is used. Off time setting for constant t_{OFF} chopper: $N_{CLK} = 12 + 32 * t_{OFF}$. Minimum is 64 clocks.

Setting this parameter to zero completely disables all driver transistors and so lets the motor free-wheel.

Object Description			
Index	Name	Object Type	Data Type
2097 _h	Chopper Off Time	Variable	UNSIGNED8

Table 96: Object Description (2097_h)

Entry Description				
Sub-index	Access	PDO Mapping	Value Range	Default Value
0	rw	no	0 / 2...15	5

Table 97: Entry Description (2097_h)



4.2.23 Object 2098_h: Smart Energy Current Minimum

This object provides the setting of the lower motor current limit for coolStep operation by scaling the CS value.

Possible values are:

- 0 – 1/2 of maximum motor current setting (section 4.2.4)
- 1 – 1/4 of maximum motor current setting (section 4.2.4)

Object Description			
Index	Name	Object Type	Data Type
2098 _h	Smart Energy Current Minimum	Variable	UNSIGNED8

Table 98: Object Description (2098_h)

Entry Description				
Sub-index	Access	PDO Mapping	Value Range	Default Value
0	rw	no	0/1	0

Table 99: Entry Description (2098_h)

4.2.24 Object 2099_h: Smart Energy Current Down Step

This object provides the setting of the number of stallGuard2 readings above the upper threshold necessary for each current decrement of the motor current.

Possible values are:

- 0 – 32 measurements – slowest decrement
- 1 – 8 measurements
- 2 – 2 measurements
- 3 – 1 measurements – fastest decrement

Object Description			
Index	Name	Object Type	Data Type
2099 _h	Smart Energy Current Down Step	Variable	UNSIGNED8

Table 100: Object Description (2099_h)

Entry Description				
Sub-index	Access	PDO Mapping	Value Range	Default Value
0	rw	no	0...3	0

Table 101: Entry Description (2099_h)



4.2.25 Object 209A_h: Smart Energy Hysteresis

This object sets the distance between the lower and the upper threshold for stallGuard2 reading. Above the upper threshold the motor current becomes decreased.

Hysteresis: (smartEnergy hysteresis value + 1) * 32

Upper stallGuard threshold: (smartEnergy hysteresis start + smartEnergy hysteresis + 1) * 32

Object Description			
Index	Name	Object Type	Data Type
209A _h	Smart Energy Hysteresis	Variable	UNSIGNED8

Table 102: Object Description (209A_h)

Entry Description				
Sub-index	Access	PDO Mapping	Value Range	Default Value
0	rw	no	0...15	0

Table 103: Entry Description (209A_h)

4.2.26 Object 209B_h: Smart Energy Current Up Step

This object sets the current increment step. The current becomes incremented for each measured stallGuard2 value below the lower threshold (see smart energy hysteresis start (object 209C_h, section 4.2.27). Possible values are:

- 0 – 1 step – slowest increment
- 1 – 2 steps
- 2 – 4 steps
- 3 – 8 steps – fastest increment

Object Description			
Index	Name	Object Type	Data Type
209B _h	Smart Energy Current Up Step	Variable	UNSIGNED8

Table 104: Object Description (209B_h)

Entry Description				
Sub-index	Access	PDO Mapping	Value Range	Default Value
0	rw	no	0...3	0

Table 105: Entry Description (209B_h)

4.2.27 Object 209C_h: Smart Energy Hysteresis Start

This object serves to set the lower threshold for the stallGuard2 value (see smart Energy current up step (section 4.2.26). Setting this to 0 disables the coolStep function.



Object Description			
Index	Name	Object Type	Data Type
209C _h	Smart Energy Hysteresis Start	Variable	UNSIGNED8

Table 106: Object Description (209C_h)

Entry Description				
Sub-index	Access	PDO Mapping	Value Range	Default Value
0	rw	no	0...15	0

Table 107: Entry Description (209C_h)

4.2.28 Object 209D_h: Smart Energy Filter Enable

This object is used to set the stallGuard2 filter for more precision of the measurement. It reduces the measurement frequency to one measurement per four fullsteps if set.

In most cases it is expedient to set the filtered mode when using coolStep. Use the standard mode for step loss detection.

Possible values are:

- 0 – standard mode
- 1 – filtered mode

Object Description			
Index	Name	Object Type	Data Type
209D _h	Smart Energy Filter Enable	Variable	UNSIGNED8

Table 108: Object Description (209D_h)

Entry Description				
Sub-index	Access	PDO Mapping	Value Range	Default Value
0	rw	no	0/1	0

Table 109: Entry Description (209D_h)

4.2.29 Object 209E_h: stallGuard2 Threshold

This signed value controls the stallGuard2 threshold level for stall output and sets the optimum measurement range for readout. A lower value gives a higher sensitivity. Zero is the starting value. A higher value makes stallGuard2 less sensitive and requires more torque to indicate a stall.

Object Description			
Index	Name	Object Type	Data Type
209E _h	stallGuard2 Threshold	Variable	SIGNED8

Table 110: Object Description (209E_h)

Entry Description				
Sub-index	Access	PDO Mapping	Value Range	Default Value
0	rw	no	-63...63	0

Table 111: Entry Description (209E_h)

4.2.30 Object 20A1_h: Short Protection Disable

This object is used to enable or to disable the short to ground protection. Normally there is no need to change this. Use the default value.

Possible values are:

- 0 – Short to GND protection enabled
- 1 – Short to GND protection disabled

Object Description			
Index	Name	Object Type	Data Type
20A1 _h	Short Protection Disable	Variable	UNSIGNED8

Table 112: Object Description (20A1_h)

Entry Description				
Sub-index	Access	PDO Mapping	Value Range	Default Value
0	rw	no	0/1	0

Table 113: Entry Description (20A1_h)

4.2.31 Object 20A3_h: Vsense

This object is used for setting the sense resistor voltage based current scaling. *Use the default value and change only when recommended by Trinamic.*

Possible settings are:

- 0 - Full scale sense resistor voltage is 1/18 VDD
- 1 - Full scale sense resistor voltage is 1/36 VDD

Object Description			
Index	Name	Object Type	Data Type
20A3 _h	Vsense	Variable	UNSIGNED8

Table 114: Object Description (20A3_h)

Entry Description				
Sub-index	Access	PDO Mapping	Value Range	Default Value
0	rw	no	0/1	0

Table 115: Entry Description (20A3_h)

4.2.32 Object 20A4_h: Stop on Stall

Below this speed the motor will not be stopped. Above this speed the motor will be stopped in case the stallGuard2 load value reaches zero.

Object Description			
Index	Name	Object Type	Data Type
20A4 _h	Stop on Stall	Variable	UNSIGNED32

Table 116: Object Description (20A4_h)

Entry Description				
Sub-index	Access	PDO Mapping	Value Range	Default Value
0	rw	no	0...2147483647	0

Table 117: Entry Description (20A4_h)

4.2.33 Object 20A5_h: Smart Energy Threshold Speed

The coolStep functionality will be enabled when the actual speed is above this speed. It will be disabled again when the actual speed drops below this value.

Object Description			
Index	Name	Object Type	Data Type
20A5 _h	Smart Energy Threshold Speed	Variable	UNSIGNED32

Table 118: Object Description (20A5_h)

Entry Description				
Sub-index	Access	PDO Mapping	Value Range	Default Value
0	rw	no	0...2147483647	0

Table 119: Entry Description (20A5_h)

4.2.34 Object 2100_h: Home Offset Display

This object shows the home offset. The value is given in microsteps.

Object Description			
Index	Name	Object Type	Data Type
2100 _h	Home Offset Display	Variable	SIGNED32

Table 120: Object Description (2100_h)

Entry Description				
Sub-index	Access	PDO Mapping	Value Range	Default Value
0	ro	no	-2147483648...2147483647	0

Table 121: Entry Description (2100_h)



4.2.35 Object 2101_h: Actual Load Value

This object shows the home offset. The value is given in microsteps.

Object Description			
Index	Name	Object Type	Data Type
2101 _h	Home Offset Display	Variable	UNSIGNED16

Table 122: Object Description (2101_h)

Entry Description				
Sub-index	Access	PDO Mapping	Value Range	Default Value
0	ro	no	0...1023	0

Table 123: Entry Description (2101_h)

4.2.36 Object 2102_h: Driver Error Flags

This object shows the error flags of the motor driver IC.

Error Flags		
Bit	Name	Meaning
7	OT	Overtemperature
6	OTPW	Temperature pre-warning
5	UV	Undervoltage
4	OCHS	Overcurrent high side
3	OLB	Open load on bridge B
2	OLA	Open load on bridge A
1	OCB	Overcurrent on bridge B
0	OCA	Overcurrent on bridge A

Table 124: Driver Error Flags (2102_h)

Object Description			
Index	Name	Object Type	Data Type
2102 _h	Home Offset Display	Variable	UNSIGNED8

Table 125: Object Description (2102_h)

Entry Description				
Sub-index	Access	PDO Mapping	Value Range	Default Value
0	ro	no	0...255	0

Table 126: Entry Description (2102_h)

4.2.37 Object 2107_h: Microstep resolution display

This object shows the microstep resolution, set by object 2000_h (please see section 4.2.1).



Object Description			
Index	Name	Object Type	Data Type
2107 _h	Microstep resolution display	Variable	UNSIGNED8

Table 127: Object Description (2107_h)

Entry Description				
Sub-index	Access	PDO Mapping	Value Range	Default Value
0	ro	no	0...8	8

Table 128: Entry Description (2107_h)

4.2.38 Object 210B_h: Step Counter

This object shows the overall number of microsteps done by this motor so far. The value can be read as a 64 bit value (sub-index 3) or split into two 32 bit values (sub-index 1 and sub-index 2).

Object Description			
Index	Name	Object Type	Data Type
210B _h	Step Counter	Variable	RECORD

Table 129: Object Description (210B_h)

Entry Description					
Sub-index	Description	Access	PDO Mapping	Value Range	Default Value
1	Lower 32 Bits	ro	no	0... ffffffff _h	0
2	Higher 32 Bits	ro	no	0... ffffffff _h	0
3	64 Bit Value	ro	no	0... ffffffffffffffff _h	0

Table 130: Entry Description (210B_h)

4.2.39 Object 2700_h: TMCL Direct Communication

After writing the make signature 656b616d_h to this object the drive switches to TMCL mode. The drive can then only be controlled via TMCL commands written to the OS command object 1023/01_h. The drive can only be reset to normal CANopen functionality using the DS-301 reset application command.

Object Description			
Index	Name	Object Type	Data Type
2700 _h	TMCL Direct Communication	Variable	UNSIGNED32

Table 131: Object Description (2700_h)

Entry Description				
Sub-index	Access	PDO Mapping	Value Range	Default Value
0	rw	no	656b616d _h	0

Table 132: Entry Description (2700_h)



4.2.40 Object 2701_h: Manufacturer Specific Mode

Writing the make signature to this object turns on the manufacturer specific mode. The manufacturer specific mode can be turned off again by writing the kill signature to this object. The manufacturer specific mode has the following features:

- PDOs do not need to be disabled and re-enabled when the PDO mapping is to be changed.
- The RTR bit in the COB-ID of PDO definitions is ignored.

read:	0	=	manufacturer specific mode is inactive
	1	=	manufacturer specific mode is active
write:	656b616d _h	=	make signature
	6c6c696b _h	=	kill signature

Object Description			
Index	Name	Object Type	Data Type
2701 _h	Manufacturer Specific Mode	Variable	UNSIGNED32

Table 133: Object Description (2701_h)

Entry Description				
Sub-index	Access	PDO Mapping	Value Range	Default Value
0	rw	no	see above	0

Table 134: Entry Description (2701)_h

4.2.41 Object 2702_h: Device Digital Inputs

Bits 19...16 of this object reflect the states of the four general purpose inputs of the module.

Bit Definitions	
Bit	Description
16	IN0
17	IN1
18	IN2
19	IN3

Table 135: Bit Definitions (2702_h)

Object Description			
Index	Name	Object Type	Data Type
2702 _h	Device Digital Inputs	Variable	UNSIGNED32

Table 136: Object Description (2702_h)

Entry Description				
Sub-index	Access	PDO Mapping	Value Range	Default Value
0	ro	no	-	0

Table 137: Entry Description (2702)_h



4.2.42 Object 2703_h: Device Digital Outputs

With this object the digital outputs (general purpose outputs) can be set. Bits 19...16 of sub index 1 switch outputs OUT0, OUT1, OUT2 and OUT3 of the module. Bits 19...16 of sub index 2 determine which outputs can be switched. The number of available digital outputs depends on the module type.

Bit Definitions	
Bit	Description
16	OUT0
17	OUT1
18	OUT2
19	OUT3

Table 138: Bit Definitions (2703_h)

Object Description			
Index	Name	Object Type	Data Type
2703 _h	Smart Energy Current Up Step	Variable	ARRAY

Table 139: Object Description (2703_h)

Entry Description					
Sub-index	Description	Access	PDO Mapping	Value Range	Default Value
1	Physical outputs	rw	no	UNSIGNED32	0
2	Output mask	rw	no	UNSIGNED32	0

Table 140: Entry Description (2703_h)

4.2.43 Object 2704_h: CAN Bit Rate

With this object it is possible to change the CAN bit rate. To do this, first write the new value to this object. Then, store the new setting by writing the save signature to object 2706_h. After that, reset the module. The new setting then becomes active.

Object Description			
Index	Name	Object Type	Data Type
2704 _h	CAN Bit Rate	Variable	UNSIGNED16

Table 141: Object Description (2704_h)

Entry Description				
Sub-index	Access	PDO Mapping	Value Range	Default Value
0	rw	no	20,50,100,125,250,500,800,1000	1000

Table 142: Entry Description (2704_h)

How to change the bit rate of a module:

- Write new bit rate in object 2704_h.



- Write the save signature 65766173_h to sub-index 1 of object 2706_h.
- Reset module.

4.2.44 Object 2705_h: Node ID

On modules that do not have address switches the node ID can be selected using this object. On modules with address switches the node ID is normally selected using the address switches. Only when the address switches are set to an invalid value (0 or >127) this object overrides the address switch setting. To change the node ID, first write the new node ID to this object. Then, store the new setting by writing the save signature to object 2706_h. After that, reset the module. The new setting then becomes active.

Object Description			
Index	Name	Object Type	Data Type
2705 _h	Node ID	Variable	UNSIGNED8

Table 143: Object Description (2705_h)

Entry Description				
Sub-index	Access	PDO Mapping	Value Range	Default Value
0	rw	no	1...127	1

Table 144: Entry Description (2705)_h

How to change the node ID of a module:

- Write new node ID to object 2705_h.
- Write save signature 65766173_h to sub-index 1 of object 2706_h.
- Reset the module.

4.2.45 Object 2706_h: Store

Writing the save signature to this object permanently saves changes made to objects 2704_h and 2705_h. The save signature is 65766173_h.

Object Description			
Index	Name	Object Type	Data Type
2706 _h	Store	Variable	UNSIGNED32

Table 145: Object Description (2706_h)

Entry Description				
Sub-index	Access	PDO Mapping	Value Range	Default Value
0	rw	no	save signature: 65766173 _h	1

Table 146: Entry Description (2706)_h



4.2.46 Object 2707_h: CAN Bit Rate Load

This object shows the selected CAN bit rate.

Object Description			
Index	Name	Object Type	Data Type
2707 _h	CAN Bit Rate Load	Variable	UNSIGNED8

Table 147: Object Description (2707_h)

Entry Description				
Sub-index	Access	PDO Mapping	Value Range	Default Value
0	ro	no	20...1000	depends on bit rate

Table 148: Entry Description (2707_h)

4.2.47 Object 2708_h: Node ID Load

This object shows the selected node ID.

Object Description			
Index	Name	Object Type	Data Type
2708 _h	Node ID Load	Variable	UNSIGNED8

Table 149: Object Description (2708_h)

Entry Description				
Sub-index	Access	PDO Mapping	Value Range	Default Value
0	ro	no	1..127	Depends on node ID setting

Table 150: Entry Description (2708_h)

4.2.48 Object 270E_h: Device Analog Inputs

This object shows the values of the analog inputs of the device.

Object Description			
Index	Name	Object Type	Data Type
270E _h	Device Analog Inputs	Array	UNSIGNED32

Table 151: Object Description (270E_h)

Entry Description					
Sub-index	Description	Access	PDO Mapping	Value Range	Default Value
1	Analog input 0	ro	no	0...4095	-
2	Analog input 1	ro	no	0...4095	-
3	Analog input 2	ro	no	0...4095	-
4	Analog input 3	ro	no	0...4095	-

Table 152: Entry Description (270E_h)



5 Profile specific area

The profile segment contains CiA-402 standard motion control objects. These objects control the motion control functions of the TMCM-3212. Since it is not possible to operate the modes in parallel, the user is able to activate the required function by selecting a mode of operation. The control device writes to the modes of operation object in order to select the operation mode. The drive device provides the modes of operation display object to indicate the actual activated operation mode. Controlword, statusword, and set-points are used mode-specific. This implies the responsibility of the control device to avoid inconsistencies and erroneous behavior.

The following operating modes (selectable via object 6060_h, please see 5.1.6) are implemented on the TMCM-3212:

- Profile position mode (pp)
- Profile velocity mode (pv)
- Homing mode (hm)
- Cyclic position mode (csp)

This section of the manual only shows the object indices for motor #0. Of course the same objects are also available for the other motors. For the other motors, add an offset of *motor_number*·800_h to the object index. So for example the control word (object 6040_h for motor #0) can be accessed as object 6840_h for motor #1 and as object 7040_h for motor #2. Please see also section 2.4.1.

Multi-axis Object Indices	
Motor	Object Index Range
Motor #0	6000 _h – 67FF _h
Motor #1	6800 _h – 6FFF _h
Motor #2	7000 _h – 77FF _h

Table 153: Multi-axis Object Indices (Profile specific Area)

5.1 Detailed object specifications

5.1.1 Object 605A_h: Quick stop option code

This object indicates what action is performed when the quick stop function is executed. The slow down ramp is the deceleration value of the used mode of operation. The following quick stop option codes are supported in the current version of the CANopen firmware:

Value Definition	
Value	Definition
1	Slow down on <i>slow down ramp</i> and transit into <i>switch on disabled</i>
2	Slow down on <i>quick stop ramp</i> and transit into <i>switch on disabled</i>
5	Slow down on <i>slow down ramp</i> and stay in <i>quick stop active</i>
6	Slow down on <i>quick stop ramp</i> and stay in <i>quick stop active</i>

Table 154: Value Description (605A_h)

Object Description			
Index	Name	Object Type	Data Type
605A _h	Quick stop option code	Variable	SIGNED16

Table 155: Object Description (605A_h)



Entry Description				
Sub-index	Access	PDO Mapping	Value Range	Default Value
0	rw	no	1/2/5/6	2

Table 156: Entry Description (605A_h)

5.1.2 Object 605B_h: Shutdown option code

This object indicates what action is performed if there is a transition from *operation enabled* state to *ready to switch on state*. The shutdown option code always has the value 0 as only this is supported.

Value Definition	
Value	Definition
0	Disable drive function (switch off the power stage)

Table 157: Value Description (605B_h)

Object Description			
Index	Name	Object Type	Data Type
605B _h	Quick stop option code	Variable	UNSIGNED16

Table 158: Object Description (605B_h)

Entry Description				
Sub-index	Access	PDO Mapping	Value Range	Default Value
0	rw	no	0	0

Table 159: Entry Description (605B_h)

5.1.3 Object 605C_h: Disable operation option code

This object indicates what action is performed if there is a transition from *operation enabled* state to *switched on state*. The disable operation option code always has the value 1 as only this is supported. The slow down ramp is the deceleration value of the used mode of operation.

Value Definition	
Value	Definition
1	Slow down on slow down ramp

Table 160: Value Description (605C_h)

Object Description			
Index	Name	Object Type	Data Type
605C _h	Disable operation option code	Variable	UNSIGNED16

Table 161: Object Description (605C_h)



Entry Description				
Sub-index	Access	PDO Mapping	Value Range	Default Value
0	rw	no	1	1

Table 162: Entry Description (605C_h)

5.1.4 Object 605D_h: Halt option code

This object indicates what action is performed when the halt function is executed. The slow down ramp is the deceleration value of the used mode of operation. The halt option code always has the value 1 as only this is supported.

Value Definition	
Value	Definition
1	Slow down on slow down ramp and stay in <i>operation enabled</i>

Table 163: Value Description (605D_h)

Object Description			
Index	Name	Object Type	Data Type
605D _h	Halt option code	Variable	UNSIGNED16

Table 164: Object Description (605D_h)

Entry Description				
Sub-index	Access	PDO Mapping	Value Range	Default Value
0	rw	no	1	1

Table 165: Entry Description (605D_h)

5.1.5 Object 605E_h: Fault reaction option code

This object indicates what action is performed when fault is detected in the power drive system. The slow down ramp is the deceleration value of the used mode of operation. The fault reaction option code always has the value 2 as only this is supported.

Value Definition	
Value	Definition
2	Slow down on quick stop ramp

Table 166: Value Description (605E_h)

Object Description			
Index	Name	Object Type	Data Type
605E _h	Fault reaction option code	Variable	UNSIGNED16

Table 167: Object Description (605E_h)



Entry Description				
Sub-index	Access	PDO Mapping	Value Range	Default Value
0	rw	no	2	2

Table 168: Entry Description (605E_h)

5.1.6 Object 6060_h: Modes of operation

This object indicates the requested operation mode. Supported operating modes are:

Value Definition	
Value	Mode
0	No mode
1	Profile position mode (pp)
3	Profile velocity mode (pv)
6	Homing mode (hm)

Table 169: Value Description (6060_h)

The motor will not run when the operating mode is set to 0. It will be stopped when the motor is running in one of the supported operating modes and the operating mode is then switched to 0.

Object Description			
Index	Name	Object Type	Data Type
6060 _h	Modes of operation	Variable	SIGNED8

Table 170: Object Description (6060_h)

Entry Description				
Sub-index	Access	PDO Mapping	Value Range	Default Value
0	rw	refer to CiA-402	0/1/3/6	0

Table 171: Entry Description (6060_h)

5.1.7 Object 6061_h: Modes of operation

This object shows the operating mode that is currently set.

Value Definition	
Value	Mode
0	No mode
1	Profile position mode (pp)
3	Profile velocity mode (pv)
6	Homing mode (hm)

Table 172: Value Description (6061_h)

The motor will not run when the operating mode is set to 0. It will be stopped when the motor is running in one of the supported operating modes and the operating mode is then switched to 0.



Object Description			
Index	Name	Object Type	Data Type
6061 _h	Modes of operation display	Variable	SIGNED8

Table 173: Object Description (6061_h)

Entry Description				
Sub-index	Access	PDO Mapping	Value Range	Default Value
0	rw	refer to CiA-402	0/1/3/6	0

Table 174: Entry Description (6061_h)

5.1.8 Object 606A_h: Sensor selection code

This object provides the source of the velocity sensor actual value. It selects whether an encoder is to be used or not.

Value Definition	
Value	Mode
0	Encoder used
-1	No encoder

Table 175: Value Description (606A_h)

Object Description			
Index	Name	Object Type	Data Type
606A _h	Sensor selection code	Variable	SIGNED16

Table 176: Object Description (606A_h)

Entry Description				
Sub-index	Access	PDO Mapping	Value Range	Default Value
0	rw	no	0/-1	-1

Table 177: Entry Description (606A_h)

5.1.9 Object 608F_h: Position Encoder Resolution

This object defines the resolution of the encoder. The position encoder resolution is calculated by the following formula:

$$position\ encoder\ resolution = \frac{encoder\ increments}{motor\ revolutions}$$

All values are dimensionless.

Object Description			
Index	Name	Object Type	Data Type
608F _h	Position Encoder Resolution	Array	UNSIGNED32

Table 178: Object Description (608F_h)



Entry Description					
Sub-index	Description	Access	PDO Mapping	Value Range	Default Value
0	Highest sub-index supported	ro	no	2	2
1	Encoder increments	rw	no	0...2147483647	1
2	Motor revolutions	ro	no	1	1

Table 179: Entry Description (608F_h)

5.1.10 Object 60FD_h: Digital Inputs

This object contains the states of the digital inputs of the module. Starting from bit 0, every bit reflects the state of one digital input. The number of valid bits depends on the number of digital inputs on the module used.

Object Description			
Index	Name	Object Type	Data Type
60FD _h	Digital inputs	Variable	UNSIGNED32

Table 180: Object Description (60FD_h)

Entry Description				
Sub-index	Access	PDO Mapping	Value Range	Default Value
0	rw	mappable	UNSIGNED32	0

Table 181: Entry Description (60FD_h)

5.1.11 Object 6502_h: Supported Drive Modes

This object provides information on the supported drive modes. A bit that is set means that the mode is supported, a bit that is not set means that the mode is not supported by the drive.

Value Definition	
Bit	Mode
0	Profile position mode (pp)
1	Velocity mode (vl)
2	Profile velocity mode (pv)
3	Torque mode (tq)
4	Reserved
5	Homing mode (hm)
6	Interpolated position mode (ip)
7	Cyclic synchronous position mode (csp)
8	Cyclic synchronous velocity mode (csv)
9	Cyclic synchronous torque mode (cst)

Table 182: Value Definition (6502_h)

Object Description			
Index	Name	Object Type	Data Type
6502 _h	Supported drive modes	Variable	UNSIGNED32

Table 183: Object Description (6502_h)



Entry Description				
Sub-index	Access	PDO Mapping	Value Range	Default Value
0	ro	no	UNSIGNED32	Depends on supported modes.

Table 184: Entry Description (6502_h)



6 Profile position mode

A target position is applied to the trajectory generator. It is generating a position demand value for the position control loop described in the position control function.

Please refer to object 6060_h (section 5.1.6) for information about how to choose an operation mode.

Object 6061_h (section 5.1.7) shows the operation mode that is set.

6.1 Detailed Object Specifications

The following text offers detailed object specifications. For a better understanding, it is necessary to see how the state machine works.

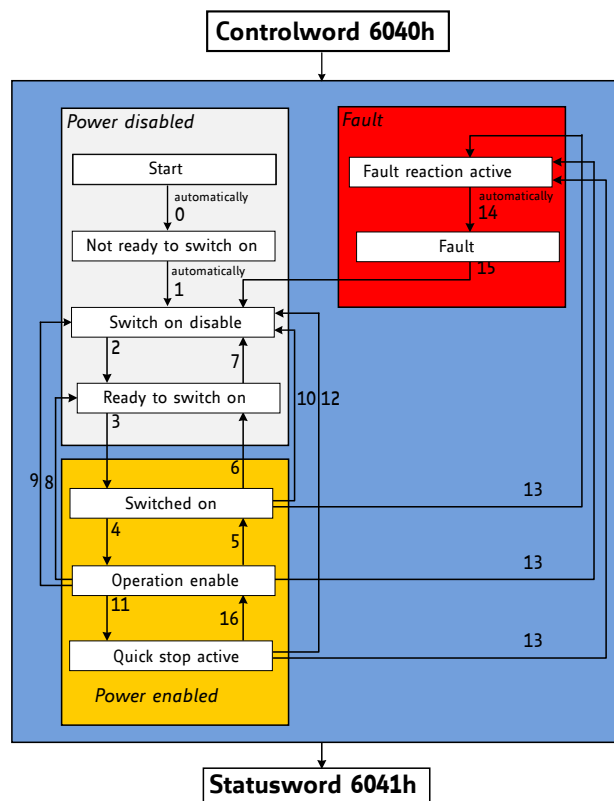

Figure 9: DS402 Finite State Machine

Notes on state transitions:

- Commands directing a change in state are processed completely and the new state achieved before additional state change commands are processed.
- Transitions 0 and 1 occur automatically at drive power-on or reset. Transition 14 occurs automatically, too. All other state changes must be directed by the host.
- Drive function disabled indicates that no current is being supplied to the motor.
- Drive function enabled indicates that current is available for the motor and profile position and profile velocity reference values may be processed.



6.1.1 Object 6040_h: Control Word

This object indicates the received command controlling the power drive system finite state automaton (PDS FSA). The CiA-402 state machine can be controlled using this object. Please refer to figure 9 for detailed information.

Structure of the control word											
15	11	10	9	8	7	6	4	3	2	1	0
nu	r	oms	h	fr	oms	eo	qs	ev	so		
MSB										LSB	

Legend: nu=not used; r=reserved; oms=operation mode specific; h=halt; fr=fault reset; eo=enable operation; qs=quick stop; ev=enable voltage; so=switch on.

Table 185: Structure of the Control Word in pp Mode

Operation mode specific bits in pp mode		
Bit	Name	Definition
4	New set point	0-to-1: the next positioning will be started.
5	Change immediately	Not supported.
6	Absolute / relative	0: New position is absolute. 1: New position is relative.
9	Change set point	Not supported.

Table 186: Operation Mode specific Bits in pp Mode

Command coding						
Command	Bits of control word					Transitions
	Bit 7	Bit 3	Bit 2	Bit 1	Bit 0	
Shutdown	0	x	1	1	0	2,6,8
Switch on	0	0	1	1	1	3
Switch on & enable operation	0	1	1	1	1	3, 4
Disable voltage	0	x	x	0	x	7,9,10,12
Quick stop	0	x	0	1	x	7,10,11
Disable operation	0	0	1	1	1	5
Enable operation	0	1	1	1	1	4, 16
Fault reset	0-to-1	x	x	x	x	15

Table 187: Command Coding

Object Description			
Index	Name	Object Type	Data Type
6040 _h	Controlword	Variable	UNSIGNED16

Table 188: Object Description (6040_h in pp Mode)

Entry Description				
Sub-index	Access	PDO Mapping	Value Range	Default Value
0	rw	see CiA402-3	See command coding above.	

Table 189: Entry Description (6040_h in pp Mode)



6.1.2 Object 6041_h: Status Word

This object provides the status of the PDS FSA. It reflects the status of the CiA-402 state machine. Please refer to figure 9 for detailed information. The object is structured as defined below. For more information about the coding please refer to the CANopen Drives and motion control device profile, part 2.

Structure of the Status Word															
15	14	13	12	11	10	9	8	7	6	5	4	3	2	1	0
dir	mot	oms	ila	tr	rm	ms	w	sod	qs	ve	f	oe	so	rtso	
MSB														LSB	

Legend: nu=not used; r=reserved; oms=operation mode specific; h=halt; fr=fault reset; eo=enable operation; qs=quick stop; ev=enable voltage; so=switch on.

Table 190: Structure of the Status Word in pp Mode

Trinamic Specific Bits		
Bit	Name	Definition
14	Motor activity	0: Motor stands still. 1: Motor rotates.
15	Direction of rotation	This bit shows the direction of rotation.

Table 191: Trinamic Specific Bits

Operation Mode specific Bits in pp Mode		
Bit	Name	Definition
10	Target reached	Set when the motor is within the position window.
12	Set point acknowledged	0: Set point processed. 1: Set point still in process.
13	Following error	Not supported.

Table 192: Operation Mode specific Bits in pp Mode

State Coding	
Status word	FSA state
xxxx xxxx x0xx 0000 _h	Not ready to switch on
xxxx xxxx x1xx 0000 _h	Switch on disabled
xxxx xxxx x01x 0001 _h	Ready to switch on
xxxx xxxx x01x 0011 _h	Switched on
xxxx xxxx x01x 0111 _h	Operation enabled
xxxx xxxx x00x 0111 _h	Quick stop active
xxxx xxxx x0xx 1111 _h	Fault reaction active
xxxx xxxx x0xx 1000 _h	Fault

Table 193: State Coding

Object Description			
Index	Name	Object Type	Data Type
6041 _h	Controlword	Variable	UNSIGNED16

Table 194: Object Description (6041_h in pp Mode)



Entry Description				
Sub-index	Access	PDO Mapping	Value Range	Default Value
0	rw	see CiA402-3	See state coding above.	

Table 195: Entry Description (6041_h in pp Mode)

6.1.3 Object 6062_h: Position Demand Value

This object provides the demanded position value. The value is given in microsteps. Object 6062_h indicates the actual position that the motor should have. It is not to be confused with objects 6063_h and 6064_h.

Object Description			
Index	Name	Object Type	Data Type
6062 _h	Position Demand Value	Variable	SIGNED32

Table 196: Object Description (6062_h)

Entry Description				
Sub-index	Access	PDO Mapping	Value Range	Default Value
0	ro	Refer to CiA402-3	SIGNED32	no

Table 197: Entry Description (6062_h)

6.1.4 Object 6063_h: Position Actual Internal Value

This object provides the actual value of the encoder or the motor. Please use the sensor selection object 606A_h (see section 5.1.8) for selecting the motor or the encoder first. Object 6063_h indicates the actual position of the encoder or the motor, re-scaled to the microstep resolution. The value is given in microsteps.

Object Description			
Index	Name	Object Type	Data Type
6063 _h	Position Actual Internal Value	Variable	SIGNED32

Table 198: Object Description (6063_h)

Entry Description				
Sub-index	Access	PDO Mapping	Value Range	Default Value
0	ro	Refer to CiA402-3	SIGNED32	no

Table 199: Entry Description (6063_h)

6.1.5 Object 6064_h: Position Actual Internal Value

This object provides the actual value of the position measurement device. It always contains the same value as object 6063_h.



Object Description			
Index	Name	Object Type	Data Type
6064 _h	Position Actual Internal Value	Variable	SIGNED32

Table 200: Object Description (6064_h)

Entry Description				
Sub-index	Access	PDO Mapping	Value Range	Default Value
0	ro	Refer to CiA402-3	SIGNED32	no

Table 201: Entry Description (6064_h)

6.1.6 Object 6065_h: Following Error Window

This object indicates the configured range of tolerated position values symmetrically to the position demand value. If the position actual value is out of the following error window, a following error occurs. A following error may occur when a drive is blocked, unreachable profile velocity occurs, or at wrong closed-loop coefficients. The value shall be given in microsteps.

When the difference between motor position (object 6062_h) and encoder position (object 6063_h or 6064_h) is greater than the value set here, the motor will be stopped and an emergency message will be sent. Setting this object to zero will turn off this feature completely.

Setting this object to a too low value will lead to false alarms.

Object Description			
Index	Name	Object Type	Data Type
6065 _h	Following Error Window	Variable	UNSIGNED32

Table 202: Object Description (6065_h)

Entry Description				
Sub-index	Access	PDO Mapping	Value Range	Default Value
0	rw	no	0...2147483647	0

Table 203: Entry Description (6065_h)

6.1.7 Object 6067_h: Position Window

This object indicates the configured symmetrical range of accepted positions relative to the target position. If the actual value of the position encoder is within the position window, this target position is regarded as having been reached. The value is given in increments. If the value of the position window is FFFFFFFF_h, the position window control is switched off. If this object is set to zero, the target reached event will be signaled when the demand position (6062_h) has reached the target position (6064_h). When the position window is set to a value greater than zero, the target reached event will be signaled when the actual encoder position value (6064_h) is within $(target_position - position_window)$ and $(target_position + position_window)$.



Object Description			
Index	Name	Object Type	Data Type
6067 _h	Position Window	Variable	UNSIGNED32

Table 204: Object Description (6067_h)

Entry Description				
Sub-index	Access	PDO Mapping	Value Range	Default Value
0	rw	no	UNSIGNED32	FFFFFFF _h

Table 205: Entry Description (6067_h)

6.1.8 Object 6068_h: Position Window Time

This object indicates the configured time, during which the actual position within the position window is measured. The value is given in ms. If this object is set to a value greater than zero and also the position window (6067_h) is set to a value greater than zero the target reached event will not be signaled until the actual position (6064_h) is at least as many milliseconds within the position window as defined by this object.

Object Description			
Index	Name	Object Type	Data Type
6068 _h	Position Window Time	Variable	UNSIGNED16

Table 206: Object Description (6068_h)

Entry Description				
Sub-index	Access	PDO Mapping	Value Range	Default Value
0	rw	no	UNSIGNED16	0

Table 207: Entry Description (6068_h)

6.1.9 Object 606C_h: Velocity Actual Value

This object shows the actual velocity value of the motor. The value is given in internal or user-defined velocity units (depending on object 208C_h, described in section 4.2.15).

Object Description			
Index	Name	Object Type	Data Type
606C _h	Velocity Actual Value	Variable	SIGNED32

Table 208: Object Description (606C_h)

Entry Description				
Sub-index	Access	PDO Mapping	Value Range	Default Value
0	ro	Refer to CiA402-3	SIGNED32	no

Table 209: Entry Description (606C_h)

6.1.10 Object 607A_h: Target Position

The target position is the position that the drive should move to in profile position mode using the current settings of motion control parameters (such as velocity, acceleration, deceleration, motion profile type etc.). The value of this object is interpreted as absolute or relative depending on the abs/rel flag in the controlword. It is given in microsteps.

Object Description			
Index	Name	Object Type	Data Type
607A _h	Target Position	Variable	SIGNED32

Table 210: Object Description (607A_h in pp Mode)

Entry Description				
Sub-index	Access	PDO Mapping	Value Range	Default Value
0	rw	Refer to CiA402-3	SIGNED32	0

Table 211: Entry Description (607A_h in pp Mode)

6.1.11 Object 607D_h: Software Position Limit

This object indicates the configured maximal and minimal software position limits. These parameters define the absolute position limits for the position demand value and the position actual value. Every new target position is checked against these limits. The limit positions are always relative to the machine home position. Before being compared with the target position, they are corrected internally by the home offset as follows:

$$\text{Corrected_min_position_limit} = \text{min_position_limit} - \text{home_offset}$$

$$\text{Corrected_max_position_limit} = \text{max_position_limit} - \text{home_offset}$$

Object Description			
Index	Name	Object Type	Data Type
607D _h	Software Position Limit	Array	SIGNED32

Table 212: Object Description (607D_h)

Entry Description					
Sub-index	Description	Access	PDO Mapping	Value Range	Default Value
1	Minimum Position Limit	rw	no	SIGNED32	-2147483648
2	Maximum Position Limit	rw	no	SIGNED32	2147483647

Table 213: Entry Description (607D_h)

6.1.12 Object 6081_h: Profile Velocity

This object indicates the configured velocity normally attained at the end of the acceleration ramp during a profiled motion and is valid for both directions of motion. The profile velocity is the maximum velocity used when driving to a new position. It is given in internal or user specific units (depending on object 208C_h, section 4.2.15).



Object Description			
Index	Name	Object Type	Data Type
6081 _h	Profile Velocity	Variable	SIGNED32

Table 214: Object Description (6081_h)

Entry Description				
Sub-index	Access	PDO Mapping	Value Range	Default Value
0	rw	no	SIGNED32	0

Table 215: Entry Description (6081_h)

6.1.13 Object 6082_h: End Velocity

This object indicates the configured velocity normally attained at the end of the deceleration ramp during a profiled motion and is valid for both directions of motion. The end velocity is the velocity used when reaching the new position. It is given in internal or user specific units (depending on object 208C_h, section 4.2.15).

Object Description			
Index	Name	Object Type	Data Type
6082 _h	End Velocity	Variable	SIGNED32

Table 216: Object Description (6082_h)

Entry Description				
Sub-index	Access	PDO Mapping	Value Range	Default Value
0	rw	no	SIGNED32	0

Table 217: Entry Description (6082_h)

6.1.14 Object 6083_h: Profile Acceleration

This object indicates the configured acceleration. Object 6083_h sets the maximum acceleration to be used in profile position and profile velocity mode.

The units for object 6083_h can be chosen with object 208E_h, described in section 4.2.16.

In profile velocity mode, this object also sets the deceleration to be used (the deceleration ramp is always the same as the acceleration ramp in pv mode).

Object Description			
Index	Name	Object Type	Data Type
6083 _h	Profile Acceleration	Variable	SIGNED32

Table 218: Object Description (6083_h)

Entry Description				
Sub-index	Access	PDO Mapping	Value Range	Default Value
0	rw	no	SIGNED32	0

Table 219: Entry Description (6083_h)

6.1.15 Object 6084_h: Profile Deceleration

This object indicates the configured deceleration. Object 6084_h sets the maximum deceleration to be used in profile positioning mode.

The units for object 6084_h can be chosen with object 208E_h, described in section 4.2.16.

Object Description			
Index	Name	Object Type	Data Type
6084 _h	Profile Deceleration	Variable	SIGNED32

Table 220: Object Description (6084_h)

Entry Description				
Sub-index	Access	PDO Mapping	Value Range	Default Value
0	rw	no	SIGNED32	0

Table 221: Entry Description (6084_h)

6.1.16 Object 6085_h: Quick Stop Deceleration

This object indicates the configured deceleration used to stop the motor when the quick stop function is activated and the quick stop code object 605A_h is set to 2 (or 6). The value is given in the same unit as profile acceleration object 6083_h.

Object Description			
Index	Name	Object Type	Data Type
6085 _h	Quick stop deceleration	Variable	UNSIGNED32

Table 222: Object Description (6085_h)

Entry Description				
Sub-index	Access	PDO Mapping	Value Range	Default Value
0	rw	no	UNSIGNED32	51200

Table 223: Entry Description (6085_h)

6.1.17 Object 60F2_h: Positioning Option Code

This object indicates the positioning behaviour in profile position mode. Only bits 0 and 1 (relative option) are supported.

Bit Definitions		
Bit 1	Bit 0	Definition
0	0	Positioning moves shall be performed relative to the preceding (internal absolute) target position.
0	1	Positioning moves shall be performed relative to the actual position demand value (object 6063 _h).
1	0	Positioning moves shall be performed relative to the position actual value (object 6064 _h).
1	1	reserved

Table 224: Bit Definitions of Object 60F2_h



Object Description			
Index	Name	Object Type	Data Type
60F2 _h	Positioning option code	Variable	UNSIGNED16

Table 225: Object Description (60F2_h)

Entry Description				
Sub-index	Access	PDO Mapping	Value Range	Default Value
0	rw	no	UNSIGNED16	0

Table 226: Entry Description (60F2_h)

6.2 How to move a Motor in pp Mode

Here is a little example that shows how to get a motor running in pp mode. In this little example we assume that the module has been reset (and then switched to pre-operational or operational) by NMT commands before. Please note that the values are decimal.

- If you do not have any limit switches connected, first disable the limit switch inputs by writing 3 to object 2005_h.
- Select pp mode by writing 1 to object 6060_h.
- Write 6 to object 6040_h to switch to READY_TO_SWITCH_ON state.
- Write 7 to object 6040_h to switch to SWITCHED_ON state.
- Write 15 to object 6040_h to switch to OPERATION_ENABLED state.
- Write the desired target position (e.g. 500000) to object 607A_h.
- Mark the new target position as active by writing 31 to object 6040_h. The motor starts moving now.
- Reset the activation by writing 15 to object 6040_h (this can be done while the motor is still moving).



7 Profile velocity mode

The profile velocity mode is used to control the velocity of the drive without a special regard of the position. It contains limit functions and trajectory generation.

The profile velocity mode covers the following sub-functions:

- Demand value input via trajectory generator.
- Monitoring of the profile velocity using a window-function.
- Monitoring of velocity actual value using a threshold.

The operation of the reference value generator and its input parameters include:

- Profile velocity
- Profile acceleration
- Profile deceleration
- Emergency stop
- Motion profile type

7.1 Detailed Object Specifications

7.1.1 Object 6040_n: Control Word

This object indicates the received command controlling the power drive system finite state automaton (PDS FSA). The CiA-402 state machine can be controlled using this object. Please refer to figure 9 for detailed information.

In pv mode the control word does not contain any operation mode specific bits.

Structure of the control word											
15	11	10	9	8	7	6	4	3	2	1	0
nu	r	r	h	fr	r	eo	qs	ev	so		
MSB										LSB	

Legend: nu=not used; r=reserved; h=halt; fr=fault reset; eo=enable operation; qs=quick stop; ev=enable voltage; so=switch on.

Table 227: Structure of the Control Word in pv Mode

Command coding						
Command	Bits of control word					Transitions
	Bit 7	Bit 3	Bit 2	Bit 1	Bit 0	
Shutdown	0	x	1	1	0	2,6,8
Switch on	0	0	1	1	1	3
Switch on & enable operation	0	1	1	1	1	3, 4
Disable voltage	0	x	x	0	x	7,9,10,12
Quick stop	0	x	0	1	x	7,10,11
Disable operation	0	0	1	1	1	5
Enable operation	0	1	1	1	1	4, 16
Fault reset	0-to-1	x	x	x	x	15

Table 228: Command Coding



Object Description			
Index	Name	Object Type	Data Type
6040 _h	Controlword	Variable	UNSIGNED16

Table 229: Object Description (6040_h in pv Mode)

Entry Description				
Sub-index	Access	PDO Mapping	Value Range	Default Value
0	rw	see CiA402-3	See command coding above.	

Table 230: Entry Description (6040_h in pv Mode)

7.1.2 Object 6041_h: Status Word

This object provides the status of the PDS FSA. It reflects the status of the CiA-402 state machine. Please refer to figure 9 for detailed information. The object is structured as defined below. For more information about the coding please refer to the CANopen Drives and motion control device profile, part 2.

Structure of the Status Word															
15	14	13	12	11	10	9	8	7	6	5	4	3	2	1	0
dir	mot	oms	ila	tr	rm	ms	w	sod	qs	ve	f	oe	so	rtso	
MSB														LSB	

Legend: nu=not used; r=reserved; oms=operation mode specific; h=halt; fr=fault reset; eo=enable operation; qs=quick stop; ev=enable voltage; so=switch on.

Table 231: Structure of the Status Word in pv Mode

Trinamic Specific Bits		
Bit	Name	Definition
14	Motor activity	0: Motor stands still. 1: Motor rotates.
15	Direction of rotation	This bit shows the direction of rotation.

Table 232: Trinamic Specific Bits

Operation Mode specific Bits in pv Mode		
Bit	Name	Definition
10	Target reached	Indicates that the target speed has been reached.
12	Speed	Not supported.
13	Max. slippage error	Not supported.

Table 233: Operation Mode specific Bits in pv Mode



State Coding	
Status word	FSA state
xxxx xxxx x0xx 0000 _h	Not ready to switch on
xxxx xxxx x1xx 0000 _h	Switch on disabled
xxxx xxxx x01x 0001 _h	Ready to switch on
xxxx xxxx x01x 0011 _h	Switched on
xxxx xxxx x01x 0111 _h	Operation enabled
xxxx xxxx x00x 0111 _h	Quick stop active
xxxx xxxx x0xx 1111 _h	Fault reaction active
xxxx xxxx x0xx 1000 _h	Fault

Table 234: State Coding

Object Description			
Index	Name	Object Type	Data Type
6041 _h	Controlword	Variable	UNSIGNED16

Table 235: Object Description (6041_h in pv Mode)

Entry Description				
Sub-index	Access	PDO Mapping	Value Range	Default Value
0	rw	see CiA402-3	See state coding above	

Table 236: Entry Description (6041_h in pv Mode)

7.1.3 Object 6062_h: Position Demand Value

This object provides the demanded position value. The value is given in microsteps. Object 6062_h indicates the actual position that the motor should have. It is not to be confused with objects 6063_h and 6064_h.

Object Description			
Index	Name	Object Type	Data Type
6062 _h	Position Demand Value	Variable	SIGNED32

Table 237: Object Description (6062_h)

Entry Description				
Sub-index	Access	PDO Mapping	Value Range	Default Value
0	ro	Refer to CiA402-3	SIGNED32	no

Table 238: Entry Description (6062_h)

7.1.4 Object 6063_h: Position Actual Internal Value

This object provides the actual value of the encoder or the motor. Please use the sensor selection object 606A_h (see section 5.1.8) for selecting the motor or the encoder first. Object 6063_h indicates the actual position of the encoder or the motor, re-scaled to the microstep resolution. The value is given in microsteps.



Object Description			
Index	Name	Object Type	Data Type
6063 _h	Position Actual Internal Value	Variable	SIGNED32

Table 239: Object Description (6063_h)

Entry Description				
Sub-index	Access	PDO Mapping	Value Range	Default Value
0	ro	Refer to CiA402-3	SIGNED32	no

Table 240: Entry Description (6063_h)

7.1.5 Object 6064_h: Position Actual Internal Value

This object provides the actual value of the position measurement device. It always contains the same value as object 6063_h.

Object Description			
Index	Name	Object Type	Data Type
6064 _h	Position Actual Internal Value	Variable	SIGNED32

Table 241: Object Description (6064_h)

Entry Description				
Sub-index	Access	PDO Mapping	Value Range	Default Value
0	ro	Refer to CiA402-3	SIGNED32	no

Table 242: Entry Description (6064_h)

7.1.6 Object 6065_h: Following Error Window

This object indicates the configured range of tolerated position values symmetrically to the position demand value. If the position actual value is out of the following error window, a following error occurs. A following error may occur when a drive is blocked, unreachable profile velocity occurs, or at wrong closed-loop coefficients. The value shall be given in microsteps.

When the difference between motor position (object 6062_h) and encoder position (object 6063_h or 6064_h) is greater than the value set here, the motor will be stopped and an emergency message will be sent. Setting this object to zero will turn off this feature completely.

Setting this object to a too low value will lead to false alarms.

Object Description			
Index	Name	Object Type	Data Type
6065 _h	Following Error Window	Variable	UNSIGNED32

Table 243: Object Description (6065_h)



Entry Description				
Sub-index	Access	PDO Mapping	Value Range	Default Value
0	rw	no	0...2147483647	0

Table 244: Entry Description (6065_h)

7.1.7 Object 606C_h: Velocity Actual Value

This object shows the actual velocity value of the motor. The value is given in internal or user-defined velocity units (depending on object 208C_h, described in section 4.2.15).

Object Description			
Index	Name	Object Type	Data Type
606C _h	Velocity Actual Value	Variable	SIGNED32

Table 245: Object Description (606C_h)

Entry Description				
Sub-index	Access	PDO Mapping	Value Range	Default Value
0	ro	Refer to CiA402-3	SIGNED32	no

Table 246: Entry Description (606C_h)

7.1.8 Object 607D_h: Software Position Limit

This object indicates the configured maximal and minimal software position limits. These parameters define the absolute position limits for the position demand value and the position actual value. Every new target position is checked against these limits. The limit positions are always relative to the machine home position. Before being compared with the target position, they are corrected internally by the home offset as follows:

$$\begin{aligned} \text{Corrected_min_position_limit} &= \text{min_position_limit} - \text{home_offset} \\ \text{Corrected_max_position_limit} &= \text{max_position_limit} - \text{home_offset} \end{aligned}$$

Object Description			
Index	Name	Object Type	Data Type
607D _h	Software Position Limit	Array	SIGNED32

Table 247: Object Description (607D_h)

Entry Description					
Sub-index	Description	Access	PDO Mapping	Value Range	Default Value
1	Minimum Position Limit	rw	no	SIGNED32	-2147483648
2	Maximum Position Limit	rw	no	SIGNED32	2147483647

Table 248: Entry Description (607D_h)



7.1.9 Object 6083_h: Profile Acceleration

This object indicates the configured acceleration. Object 6083_h sets the maximum acceleration to be used in profile position and profile velocity mode.

The units for object 6083_h can be chosen with object 208E_h, described in section 4.2.16.

In profile velocity mode, this object also sets the deceleration to be used (the deceleration ramp is always the same as the acceleration ramp in pv mode).

Object Description			
Index	Name	Object Type	Data Type
6083 _h	Profile Acceleration	Variable	SIGNED32

Table 249: Object Description (6083_h)

Entry Description				
Sub-index	Access	PDO Mapping	Value Range	Default Value
0	rw	no	SIGNED32	0

Table 250: Entry Description (6083_h)

7.1.10 Object 6085_h: Quick Stop Deceleration

This object indicates the configured deceleration used to stop the motor when the quick stop function is activated and the quick stop code object 605A_h is set to 2 (or 6). The value is given in the same unit as profile acceleration object 6083_h.

Object Description			
Index	Name	Object Type	Data Type
6085 _h	Quick stop deceleration	Variable	UNSIGNED32

Table 251: Object Description (6085_h)

Entry Description				
Sub-index	Access	PDO Mapping	Value Range	Default Value
0	rw	no	UNSIGNED32	51200

Table 252: Entry Description (6085_h)

7.1.11 Object 60FF_h: Target Velocity

This object indicates the configured target velocity and is used as input for the trajectory generator. Object 60FF_h sets the target velocity when using profile velocity mode. The drive then accelerates or decelerates to that velocity using the acceleration and deceleration set by objects 6083_h and 6084_h. The values are given in units which can be selected with object 208C_h, described in section 4.2.15.

Object Description			
Index	Name	Object Type	Data Type
60FF _h	Target Velocity	Variable	SIGNED32

Table 253: Object Description (60FF_h)



Entry Description				
Sub-index	Access	PDO Mapping	Value Range	Default Value
0	rw	see CiA402-3	SIGNED32	0

Table 254: Entry Description (60FF_h)

7.2 How to move a Motor in pv Mode

Here is a little example that shows how to get a motor running in pv mode. In this little example we assume that the module has been reset (and then switched to pre-operational or operational) by NMT commands before.

- If you do not have any limit switches connected, first disable the limit switch inputs by writing 3 to object 2005_h.
- Select pv mode by writing 3 to object 6060_h.
- Write 6 to object 6040_h to switch to READY_TO_SWITCH_ON state.
- Write 7 to object 6040_h to switch to SWITCHED_ON state.
- Write 15 to object 6040_h to switch to OPERATION_ENABLED state.
- Write the desired target speed (e.g. 100000) to object 60FF_h. The motor now accelerates to that speed.
- Stop the motor by writing 0 to object 60FF_h.



8 Homing mode

This chapter describes the method by which a drive seeks the home position (reference point). There are various methods of achieving this using limit switches at the ends of travel or a home switch in mid-travel. Some methods also use the index (zero) pulse train from an incremental encoder. The user may specify the speeds, acceleration and the method of homing.

There is no output data except for those bits in the statusword which return the status or result of the homing process and the demand to the position control loops.

There are four sources of the homing signal available: these are positive and negative limit switches, the home switch and the index pulse from an encoder.

Figure 10 shows the defined input objects as well as the output objects. The user can specify the speeds, acceleration and method of homing. The home offset object 607C_h allows displacing the zero in point the coordinate system for the home position.

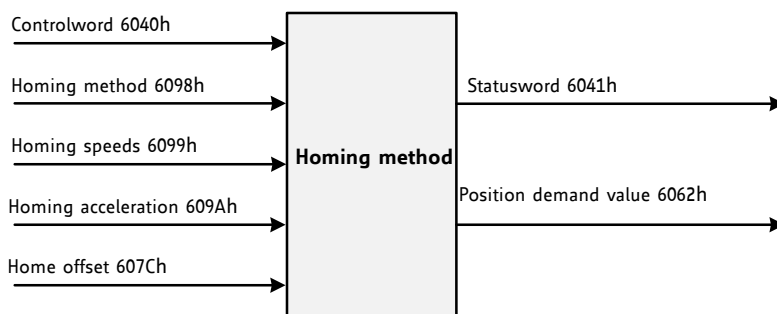

Figure 10: Homing Mode Function

Choosing a homing mode determines the following things:

- The homing signal (positive limit switch, negative limit switch, and home switch).
- The direction of actuation where appropriate.
- The position of the index pulse.

The home position and the zero position are offset by the home offset (see object 607C_h, section 8.2.4).

There are four sources of homing signals available:

- Negative and positive limit switches.
- Home switch.
- Index pulse of an encoder.

For the operation of positioning drives, an exact knowledge of the absolute position is normally required. Since for cost reasons drives often do not have an absolute encoder, a homing operation is necessary.

Please refer to object 6060_h (section 5.1.6) for information about how to choose an operation mode. Object 6061_h (section 5.1.7) shows the operation mode that is currently set.



8.1 Homing Methods

The TMCM-3212 supports a subset of different standard CANopen homing methods. The homing method that is to be used can be chosen via object 6098_h (section 8.2.5).

Supported Homing Methods	
Method	Description
0	No homing (default value for object 6098 _h).
1	Search the left end switch, then search the next encoder index pulse.
2	Search the right end switch, then search the next encoder index pulse.
3	Search the positive edge of the home switch, then search the next encoder index pulse.
5	Search the negative edge of the home switch, then search the next encoder index pulse.
17	Search the left end switch.
18	Search the right end switch.
19	Search the positive edge of the home switch.
21	Search the negative edge of the home switch.
33	Search next index pulse in negative direction.
34	Search next index pulse in positive direction.
35	The actual position is used as home position. All position values (objects 6062 _h , 6063 _h , and 6064 _h) are set to zero, but the motor will not move.

Table 255: Supported CANopen Homing Methods

When using homing methods that need end switch inputs or home switch inputs please take care of their configuration (object 2005_h, section 4.2.6).

8.1.1 Homing Method 1: Homing on negative Limit Switch and Index Pulse

Using this method, the initial direction of movement shall be leftward if the negative limit switch is inactive (here: low). The home position shall be at the first index pulse to the right of the position where the negative limit switch becomes inactive.

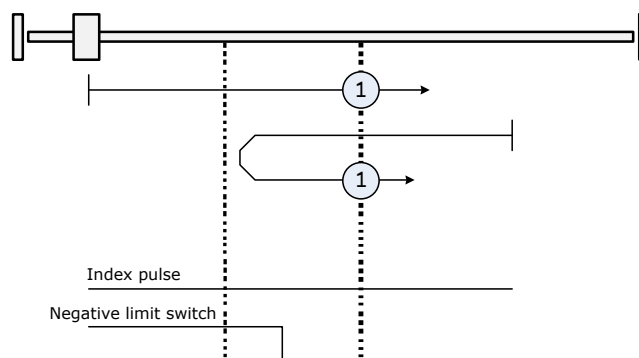

Figure 11: Homing Method 1

8.1.2 Homing Method 2: Homing on positive Limit Switch and Index Pulse

Using this method, the initial direction of movement shall be rightward if the positive limit switch is inactive (here: low). The position of home shall be at the first index pulse to the left of the position where the positive limit switch becomes inactive.



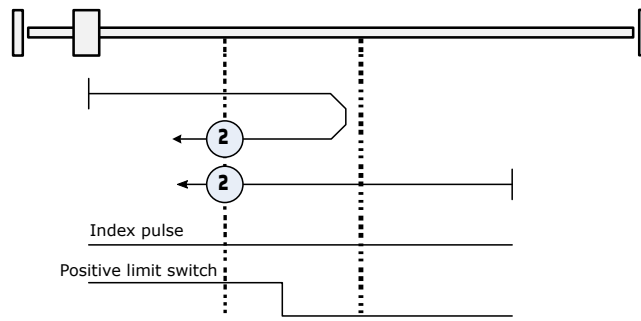

Figure 12: Homing Method 2

8.1.3 Homing Method 3: Homing on positive Home Switch and Index Pulse

Using this method, the initial direction of movement shall be dependent on the state of the home switch. The home position shall be at the index pulse to either to the left or the right of the point where the home switch changes state. If the initial position is situated so that the direction of movement shall reverse during homing, the point at which the reversal takes place is anywhere after a change of state of the home switch.

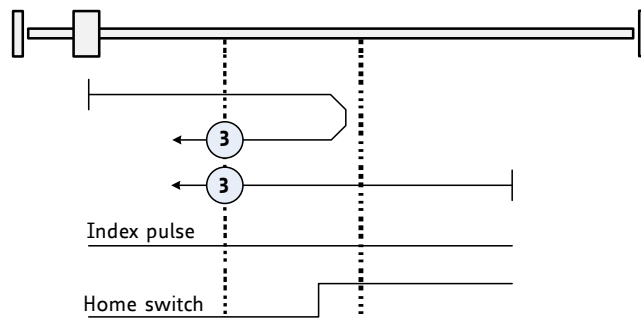

Figure 13: Homing Method 3

8.1.4 Homing Method 5: Homing on negative Home Switch and Index Pulse

Using this method, the initial direction of movement shall be dependent on the state of the home switch. The home position shall be at the index pulse to either to the left or the right of the point where the home switch changes state. If the initial position is situated so that the direction of movement shall reverse during homing, the point at which the reversal takes place is anywhere after a change of state of the home switch.



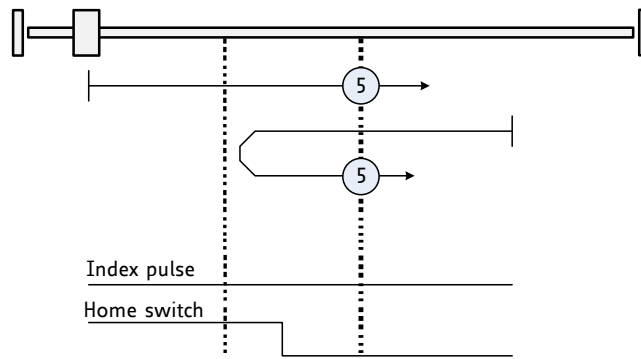

Figure 14: Homing Method 5

8.1.5 Homing Method 17, 18, 19, and 21: Homing without Index Pulse

These methods are similar to methods 1 to 5 except that the home position is not dependent on the index pulse but only dependent on the relevant home or limit switch transitions. As an example, homing method 19 (which is similar to homing method 3) is shown in figure 15.

Homing Methods 17... 21	
Method	Description
17	Search the left end switch. (Similar to method 1)
18	Search the right end switch. (Similar to method 2)
19	Search the positive edge of the home switch. (Similar to method 3)
21	Search the negative edge of the home switch. (Similar to method 5.)

Table 256: Homing Methods 17 - 21

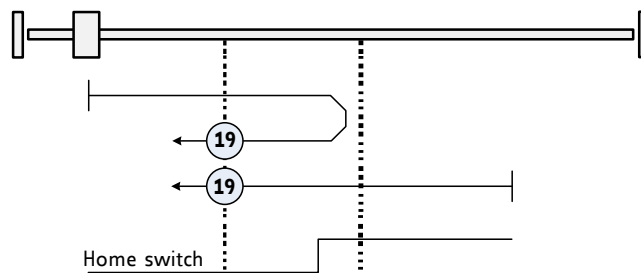

Figure 15: Homing Method 19

8.1.6 Homing Method 33 and 34: Homing on next Index Pulse

Using these methods, the direction of homing is negative or positive respectively. The home position shall be at the index pulse found in the selected direction as shown in Figure 4.10.



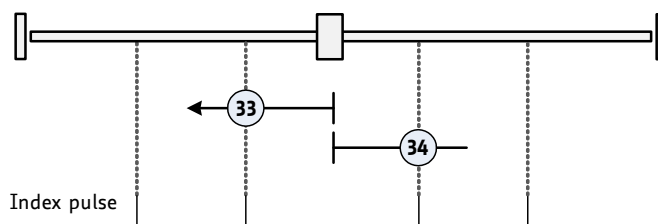

Figure 16: Homing Methods 33 and 34

8.1.7 Homing Method 35: Current position as home position

In this method, the current position shall be taken to be the home position. This method does not require the drive device to be in operation enabled state.



8.2 Detailed Object Specifications

8.2.1 Object 6040_h: Control Word

This object indicates the received command controlling the power drive system finite state automaton (PDS FSA). The CiA-402 state machine can be controlled using this object. Please refer to figure 9 for detailed information.

Structure of the control word											
15	11	10	9	8	7	6	4	3	2	1	0
nu		r	oms	h	fr	oms	eo	qs	ev	so	
MSB										LSB	

Legend: nu=not used; r=reserved; oms=operation mode specific; h=halt; fr=fault reset; eo=enable operation; qs=quick stop; ev=enable voltage; so=switch on.

Table 257: Structure of the Control Word in hm Mode

Operation mode specific bits in hm mode		
Bit	Name	Definition
4	Homing operation start	1: start homing; 0: stop homing
8	Halt	Not supported.

Table 258: Operation Mode specific Bits in hm Mode

Command coding						
Command	Bits of control word					Transitions
	Bit 7	Bit 3	Bit 2	Bit 1	Bit 0	
Shutdown	0	x	1	1	0	2,6,8
Switch on	0	0	1	1	1	3
Switch on & enable operation	0	1	1	1	1	3, 4
Disable voltage	0	x	x	0	x	7,9,10,12
Quick stop	0	x	0	1	x	7,10,11
Disable operation	0	0	1	1	1	5
Enable operation	0	1	1	1	1	4, 16
Fault reset	0-to-1	x	x	x	x	15

Table 259: Command Coding

Object Description			
Index	Name	Object Type	Data Type
6040 _h	Controlword	Variable	UNSIGNED16

Table 260: Object Description (6040_h in hm Mode)

Entry Description				
Sub-index	Access	PDO Mapping	Value Range	Default Value
0	rw	see CiA402-3	See command coding above.	

Table 261: Entry Description (6040_h in hm Mode)



8.2.2 Object 6041_h: Status Word

This object provides the status of the PDS FSA. It reflects the status of the CiA-402 state machine. Please refer to figure 9 for detailed information. The object is structured as defined below. For more information about the coding please refer to the CANopen Drives and motion control device profile, part 2.

Structure of the Status Word															
15	14	13	12	11	10	9	8	7	6	5	4	3	2	1	0
dir	mot	oms	ila	tr	rm	ms	w	sod	qs	ve	f	oe	so	rtso	
MSB														LSB	

Legend: nu=not used; r=reserved; oms=operation mode specific; h=halt; fr=fault reset; eo=enable operation; qs=quick stop; ev=enable voltage; so=switch on.

Table 262: Structure of the Status Word in hm Mode

Trinamic Specific Bits		
Bit	Name	Definition
14	Motor activity	0: Motor stands still. 1: Motor rotates.
15	Direction of rotation	This bit shows the direction of rotation.

Table 263: Trinamic Specific Bits

Operation Mode specific Bits in hm Mode		
Bit	Name	Definition
10	Target reached	Set when the zero position has been found or homing has been stopped by setting controlword bit 4 to zero.
12	Home attained	Set when zero position has been found.
13	Homing error	Not supported.

Table 264: Operation Mode specific Bits in hm Mode

State Coding	
Status word	FSA state
xxxx xxxx x0xx 0000 _h	Not ready to switch on
xxxx xxxx x1xx 0000 _h	Switch on disabled
xxxx xxxx x01x 0001 _h	Ready to switch on
xxxx xxxx x01x 0011 _h	Switched on
xxxx xxxx x01x 0111 _h	Operation enabled
xxxx xxxx x00x 0111 _h	Quick stop active
xxxx xxxx x0xx 1111 _h	Fault reaction active
xxxx xxxx x0xx 1000 _h	Fault

Table 265: State Coding

Object Description			
Index	Name	Object Type	Data Type
6041 _h	Controlword	Variable	UNSIGNED16

Table 266: Object Description (6041_h in hm Mode)



Entry Description				
Sub-index	Access	PDO Mapping	Value Range	Default Value
0	rw	see CiA402-3	See state coding above.	

Table 267: Entry Description (6041_h in hm Mode)

8.2.3 Object 606C_h: Velocity Actual Value

This object shows the actual velocity value of the motor. The value is given in internal or user-defined velocity units (depending on object 208C_h, described in section 4.2.15).

Object Description			
Index	Name	Object Type	Data Type
606C _h	Velocity Actual Value	Variable	SIGNED32

Table 268: Object Description (606C_h)

Entry Description				
Sub-index	Access	PDO Mapping	Value Range	Default Value
0	ro	Refer to CiA402-3	SIGNED32	no

Table 269: Entry Description (606C_h)

8.2.4 Object 607C_h: Home Offset

This object indicates the configured difference between the zero position for the application and the machine home position/home switch (found during homing). While homing, the machine home position is found and once the homing is completed, the zero position is offset from the home position by adding the home offset to the home position. The effect of setting the home position to a non-zero value depends on the selected homing method. The value of this object is given in microsteps. Negative values indicate the opposite direction.

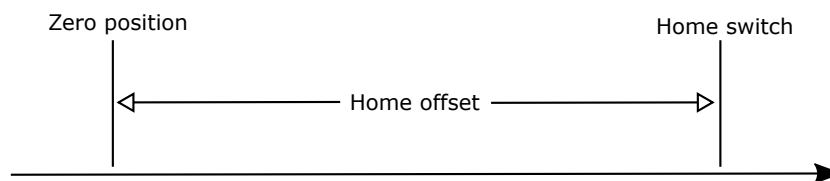

Figure 17: Home Offset

Object Description			
Index	Name	Object Type	Data Type
607C _h	Home offset	Variable	SIGNED32

Table 270: Object Description (607C_h)



Entry Description				
Sub-index	Access	PDO Mapping	Value Range	Default Value
0	rw	no	SIGNED32	0

Table 271: Entry Description (607C_h)

8.2.5 Object 6098_h: Homing Method

The homing method to be used can be selected by writing to this object. Please see table 255 for a list of homing methods supported by the current version of the TMCM-3212 CANopen firmware.

Object Description			
Index	Name	Object Type	Data Type
6098 _h	Homing method	Variable	SIGNED8

Table 272: Object Description (6098_h)

Entry Description				
Sub-index	Access	PDO Mapping	Value Range	Default Value
0	rw	no	SIGNED8	0

Table 273: Entry Description (6098_h)

8.2.6 Object 6099_h: Homing Speeds

This object indicates the configured speeds used during homing procedure. The values are given in pps units or inernal units selectable with object 208C_h (section 4.2.15). Using object 6099_h a fast and a slow homing speed can be set. In most homing modes, the home switch is searched with the fast speed first. When the home switch has been found, the motor will be decelerated to the slow speed (using the homing acceleration, object 609A_h) to search for the exact switch point. When the switch point has been found the motor will be stopped at that point.

Object Description			
Index	Name	Object Type	Data Type
6099 _h	Homing speeds	Array	UNSIGNED32

Table 274: Object Description (6099_h)

Entry Description					
Sub-index	Description	Access	PDO Mapping	Value Range	Default Value
1	Fast homing speed	rw	no	UNSIGNED32	0
2	Slow homing speed	rw	no	UNSIGNED32	0

Table 275: Entry Description (6099_h)

8.2.7 Object 609A_h: Homing Acceleration

This object indicates the configured acceleration and deceleration to be used during homing operation. The value set here will be used for acceleration and for deceleration during homing. The value is given in



units selected by object 208E_h (section 4.2.16).

Object Description			
Index	Name	Object Type	Data Type
609A _h	Homing acceleration	Variable	UNSIGNED32

Table 276: Object Description (609A_h)

Entry Description				
Sub-index	Access	PDO Mapping	Value Range	Default Value
0	rw	no	UNSIGNED32	0

Table 277: Entry Description (609A_h)

8.2.8 Object 2100_h: Home Offset Display

This object shows the home offset. The value is given in microsteps.

Object Description			
Index	Name	Object Type	Data Type
2100 _h	Home Offset Display	Variable	SIGNED32

Table 278: Object Description (2100_h)

Entry Description				
Sub-index	Access	PDO Mapping	Value Range	Default Value
0	ro	no	-2147483648...2147483647	0

Table 279: Entry Description (2100_h)

8.3 How to start a Homing in hm Mode

Here is a little example that shows how to home the motor in hm mode. In this little example we assume that the module has been reset (and then switched to pre-operational or operational) by NMT commands before. The home switch must be connected to the home switch input. It can be operated manually.

- Select hm mode by writing 6 to object 6060_h.
- Write 6 to object 6040_h to switch to READY_TO_SWITCH_ON state.
- Write 7 to object 6040_h to switch to SWITCHED_ON state.
- Write 15 to object 6040_h to switch to OPERATION_ENABLED state.
- Select homing method 19 by writing 19 to object 6098_h.
- Set the homing speeds by writing e.g. 50000 to object 6099_h sub index 1 and e.g. 10000 to object 6099_h sub index 2.
- Write 31 to object 6040_h to start the homing process.



- Press and release the home switch.
- When homing has finished, write 15 to object 6040_h again.



9 Figures Index

1	TMCM-3212	1	9	DS402 Finite State Machine	58
2	stallGuard2 Load Measurement as a Function of Load	8	10	Homing Mode Function	75
3	Energy Efficiency Example with coolStep	8	11	Homing Method 1	76
4	NMT State Machine	10	12	Homing Method 2	77
5	Communication Architecture	11	13	Homing Method 3	77
6	Device Model	12	14	Homing Method 5	78
7	coolStep Adjustment Points and Thresholds	29	15	Homing Method 19	78
8	Brake Output Timing	32	16	Homing Methods 33 and 34	79
			17	Home Offset	82



10 Tables Index

1	Abbreviations used in this Manual . . .	7	52	coolStep related Objects	30
2	Service Primitives	9	53	Object Description (2000 _h)	31
3	Service Types	9	54	Entry Description (2000 _h)	31
4	Object Dictionary	13	55	Object Description (2001 _h)	31
5	Multi-Axis Object Indices	14	56	Entry Description (2001 _h)	31
6	Object Description (1000 _h)	15	57	Object Description (2002 _h)	32
7	Entry Description (1000 _h)	15	58	Entry Description (2002 _h)	32
8	Object Description (1001 _h)	15	59	Object Description (2003 _h)	32
9	Entry Description (1001 _h)	15	60	Entry Description (2003 _h)	32
10	Error Register Bits	16	61	Object Description (2004 _h)	33
11	Value Definition (1005 _h)	16	62	Entry Description (2004 _h)	33
12	Object Description (1005 _h)	16	63	Object Description (2005 _h)	33
13	Entry Description (1005 _h)	16	64	Entry Description (2005 _h)	33
14	Object Description (1008 _h)	16	65	Bit Definitions (2005 _h)	33
15	Entry Description (1008 _h)	17	66	Object Description (200A _h)	34
16	Object Description (1009 _h)	17	67	Entry Description (200A _h) _h	34
17	Entry Description (1009 _h)	17	68	Object Description (200B _h)	34
18	Object Description (100A _h)	17	69	Entry Description (200B _h)	34
19	Entry Description (100A _h)	17	70	Object Description (200C _h)	34
20	Object Description (100C _h)	17	71	Entry Description (200C _h)	35
21	Entry Description (100C _h)	18	72	Object Description (2010 _h)	35
22	Object Description (100D _h)	18	73	Entry Description (2010 _h)	35
23	Entry Description (100D _h)	18	74	Object Description (2011 _h)	35
24	Save Signature	18	75	Entry Description (2011 _h)	35
25	Object Description (1010 _h)	19	76	Object Description (2012 _h)	35
26	Entry Description (1010 _h)	19	77	Entry Description (2012 _h)	36
27	Load Signature	20	78	Object Description (2013 _h)	36
28	Object Description (1011 _h)	20	79	Entry Description (2013 _h)	36
29	Entry Description (1011 _h)	20	80	Object Description (2089 _h)	36
30	Object Description (1014 _h)	20	81	Entry Description (2089 _h)	36
31	Entry Description (1014 _h)	20	82	Object Description (208C _h)	37
32	Object Description (1015 _h)	21	83	Entry Description (208C _h)	37
33	Entry Description (1015 _h)	21	84	Object Description (208E _h)	37
34	Value Definition (1016 _h)	21	85	Entry Description (208E _h)	37
35	Object Description (1016 _h)	21	86	Object Description (2092 _h)	37
36	Entry Description (1016 _h)	21	87	Entry Description (2092 _h)	37
37	Object Description (1017 _h)	22	88	Object Description (2093 _h)	38
38	Entry Description (1017 _h)	22	89	Entry Description (2093 _h)	38
39	Object Description (1018 _h)	22	90	Object Description (2094 _h)	38
40	Entry Description (1018 _h)	22	91	Entry Description (2094 _h)	38
41	Object Description (1029 _h)	22	92	Object Description (2095 _h)	39
42	Entry Description (1029 _h)	23	93	Entry Description (2095 _h)	39
43	Object Description (1400 _h)	23	94	Object Description (2096 _h)	39
44	Entry Description (1400 _h)	24	95	Entry Description (2096 _h)	39
45	Object Description (1600 _h)	24	96	Object Description (2097 _h)	39
46	Entry Description (1600 _h)	25	97	Entry Description (2097 _h)	39
47	Object Description (1800 _h)	26	98	Object Description (2098 _h)	40
48	Entry Description (1800 _h)	26	99	Entry Description (2098 _h)	40
49	Object Description (1A00 _h)	27	100	Object Description (2099 _h)	40
50	Entry Description (1A00 _h)	27	101	Entry Description (2099 _h)	40
51	Multi-axis Object Indices (Manufacturer specific Area)	28	102	Object Description (209A _h)	41
			103	Entry Description (209A _h)	41



104	Object Description (209B _h)	41	157	Value Description (605B _h)	52
105	Entry Description (209B _h)	41	158	Object Description (605B _h)	52
106	Object Description (209C _h)	42	159	Entry Description (605B _h)	52
107	Entry Description (209C _h)	42	160	Value Description (605C _h)	52
108	Object Description (209D _h)	42	161	Object Description (605C _h)	52
109	Entry Description (209D _h)	42	162	Entry Description (605C _h)	53
110	Object Description (209E _h)	42	163	Value Description (605D _h)	53
111	Entry Description (209E _h)	43	164	Object Description (605D _h)	53
112	Object Description (20A1 _h)	43	165	Entry Description (605D _h)	53
113	Entry Description (20A1 _h)	43	166	Value Description (605E _h)	53
114	Object Description (20A3 _h)	43	167	Object Description (605E _h)	53
115	Entry Description (20A3 _h)	43	168	Entry Description (605E _h)	54
116	Object Description (20A4 _h)	44	169	Value Description (6060 _h)	54
117	Entry Description (20A4 _h)	44	170	Object Description (6060 _h)	54
118	Object Description (20A5 _h)	44	171	Entry Description (6060 _h)	54
119	Entry Description (20A5 _h)	44	172	Value Description (6061 _h)	54
120	Object Description (2100 _h)	44	173	Object Description (6061 _h)	55
121	Entry Description (2100 _h)	44	174	Entry Description (6061 _h)	55
122	Object Description (2101 _h)	45	175	Value Description (606A _h)	55
123	Entry Description (2101 _h)	45	176	Object Description (606A _h)	55
124	Driver Error Flags (2102 _h)	45	177	Entry Description (606A _h)	55
125	Object Description (2102 _h)	45	178	Object Description (608F _h)	55
126	Entry Description (2102 _h)	45	179	Entry Description (608F _h)	56
127	Object Description (2107 _h)	46	180	Object Description (60FD _h)	56
128	Entry Description (2107 _h)	46	181	Entry Description (60FD _h)	56
129	Object Description (210B _h)	46	182	Value Definition (6502 _h)	56
130	Entry Description (210B _h)	46	183	Object Description (6502 _h)	56
131	Object Description (2700 _h)	46	184	Entry Description (6502 _h)	57
132	Entry Description (2700 _h)	46	185	Structure of the Control Word in pp Mode	59
133	Object Description (2701 _h)	47	186	Operation Mode specific Bits in pp Mode	59
134	Entry Description (2701 _h)	47	187	Command Coding	59
135	Bit Definitions (2702 _h)	47	188	Object Description (6040 _h in pp Mode)	59
136	Object Description (2702 _h)	47	189	Entry Description (6040 _h in pp Mode)	59
137	Entry Description (2702 _h)	47	190	Structure of the Staus Word in pp Mode	60
138	Bit Definitions (2703 _h)	48	191	Trinamic Specific Bits	60
139	Object Description (2703 _h)	48	192	Operation Mode specific Bits in pp Mode	60
140	Entry Description (2703 _h)	48	193	State Coding	60
141	Object Description (2704 _h)	48	194	Object Description (6041 _h in pp Mode)	60
142	Entry Description (2704 _h)	48	195	Entry Description (6041 _h in pp Mode)	61
143	Object Description (2705 _h)	49	196	Object Description (6062 _h)	61
144	Entry Description (2705 _h)	49	197	Entry Description (6062 _h)	61
145	Object Description (2706 _h)	49	198	Object Description (6063 _h)	61
146	Entry Description (2706 _h)	49	199	Entry Description (6063 _h)	61
147	Object Description (2707 _h)	50	200	Object Description (6064 _h)	62
148	Entry Description (2707 _h)	50	201	Entry Description (6064 _h)	62
149	Object Description (2708 _h)	50	202	Object Description (6065 _h)	62
150	Entry Description (2708 _h)	50	203	Entry Description (6065 _h)	62
151	Object Description (270E _h)	50	204	Object Description (6067 _h)	63
152	Entry Description (270E _h)	50	205	Entry Description (6067 _h)	63
153	Multi-axis Object Indices (Profile specific Area)	51	206	Object Description (6068 _h)	63
154	Value Description (605A _h)	51	207	Entry Description (6068 _h)	63
155	Object Description (605A _h)	51			
156	Entry Description (605A _h)	52			



208	Object Description (606C _h)	63	246	Entry Description (606C _h)	72
209	Entry Description (606C _h)	63	247	Object Description (607D _h)	72
210	Object Description (607A _h in pp Mode)	64	248	Entry Description (607D _h)	72
211	Entry Description (607A _h in pp Mode)	64	249	Object Description (6083 _h)	73
212	Object Description (607D _h)	64	250	Entry Description (6083 _h)	73
213	Entry Description (607D _h)	64	251	Object Description (6085 _h)	73
214	Object Description (6081 _h)	65	252	Entry Description (6085 _h)	73
215	Entry Description (6081 _h)	65	253	Object Description (60FF _h)	73
216	Object Description (6082 _h)	65	254	Entry Description (60FF _h)	74
217	Entry Description (6082 _h)	65	255	Supported CANopen Homing Methods	76
218	Object Description (6083 _h)	65	256	Homing Methods 17 – 21	78
219	Entry Description (6083 _h)	65	257	Structure of the Control Word in hm	
220	Object Description (6084 _h)	66		Mode	80
221	Entry Description (6084 _h)	66	258	Operation Mode specific Bits in hm	
222	Object Description (6085 _h)	66		Mode	80
223	Entry Description (6085 _h)	66	259	Command Coding	80
224	Bit Definitions of Object 60F2 _h	66	260	Object Description (6040 _h in hm Mode)	80
225	Object Description (60F2 _h)	67	261	Entry Description (6040 _h in hm Mode)	80
226	Entry Description (60F2 _h)	67	262	Structure of the Status Word in hm	
227	Structure of the Control Word in pv			Mode	81
	Mode	68	263	Trinamic Specific Bits	81
228	Command Coding	68	264	Operation Mode specific Bits in hm	
229	Object Description (6040 _h in pv Mode)	69		Mode	81
230	Entry Description (6040 _h in pv Mode)	69	265	State Coding	81
231	Structure of the Status Word in pv Mode	69	266	Object Description (6041 _h in hm Mode)	81
232	Trinamic Specific Bits	69	267	Entry Description (6041 _h in hm Mode)	82
233	Operation Mode specific Bits in pv		268	Object Description (606C _h)	82
	Mode	69	269	Entry Description (606C _h)	82
234	State Coding	70	270	Object Description (607C _h)	82
235	Object Description (6041 _h in pv Mode)	70	271	Entry Description (607C _h)	83
236	Entry Description (6041 _h in pv Mode)	70	272	Object Description (6098 _h)	83
237	Object Description (6062 _h)	70	273	Entry Description (6098 _h)	83
238	Entry Description (6062 _h)	70	274	Object Description (6099 _h)	83
239	Object Description (6063 _h)	71	275	Entry Description (6099 _h)	83
240	Entry Description (6063 _h)	71	276	Object Description (609A _h)	84
241	Object Description (6064 _h)	71	277	Entry Description (609A _h)	84
242	Entry Description (6064 _h)	71	278	Object Description (2100 _h)	84
243	Object Description (6065 _h)	71	279	Entry Description (2100 _h)	84
244	Entry Description (6065 _h)	72	280	Firmware Revision	92
245	Object Description (606C _h)	72	281	Document Revision	92



11 Supplemental Directives

11.1 Producer Information

The producer of the product TMCM-3212 is TRINAMIC GmbH & Co. KG in Hamburg, Germany; hereafter referred to as TRINAMIC. TRINAMIC is the supplier; and in this function provides the product and the production documentation to its customers.

11.2 Copyright

TRINAMIC owns the content of this user manual in its entirety, including but not limited to pictures, logos, trademarks, and resources. © Copyright 2016 TRINAMIC. All rights reserved. Electronically published by TRINAMIC, Germany.

Redistributions of source or derived format (for example, Portable Document Format or Hypertext Markup Language) must retain the above copyright notice, and the complete Datasheet User Manual documentation of this product including associated Application Notes; and a reference to other available product-related documentation.

11.3 Trademark Designations and Symbols

Trademark designations and symbols used in this documentation indicate that a product or feature is owned and registered as trademark and/or patent either by TRINAMIC or by other manufacturers, whose products are used or referred to in combination with TRINAMIC's products and TRINAMIC's product documentation.

This CANopen® Firmware Manual is a non-commercial publication that seeks to provide concise scientific and technical user information to the target user. Thus, trademark designations and symbols are only entered in the Short Spec of this document that introduces the product at a quick glance. The trademark designation /symbol is also entered when the product or feature name occurs for the first time in the document. All trademarks and brand names used are property of their respective owners.

11.4 Target User

The documentation provided here, is for programmers and engineers only, who are equipped with the necessary skills and have been trained to work with this type of product.

The Target User knows how to responsibly make use of this product without causing harm to himself or others, and without causing damage to systems or devices, in which the user incorporates the product.

11.5 Disclaimer: Life Support Systems

TRINAMIC Motion Control GmbH & Co. KG does not authorize or warrant any of its products for use in life support systems, without the specific written consent of TRINAMIC Motion Control GmbH & Co. KG. Life support systems are equipment intended to support or sustain life, and whose failure to perform, when properly used in accordance with instructions provided, can be reasonably expected to result in personal injury or death.

Information given in this document is believed to be accurate and reliable. However, no responsibility is assumed for the consequences of its use nor for any infringement of patents or other rights of third parties which may result from its use. Specifications are subject to change without notice.

11.6 Disclaimer: Intended Use

The data specified in this user manual is intended solely for the purpose of product description. No representations or warranties, either express or implied, of merchantability, fitness for a particular purpose or of any other nature are made hereunder with respect to information/specification or the products to



which information refers and no guarantee with respect to compliance to the intended use is given. In particular, this also applies to the stated possible applications or areas of applications of the product. TRINAMIC products are not designed for and must not be used in connection with any applications where the failure of such products would reasonably be expected to result in significant personal injury or death (safety-Critical Applications) without TRINAMIC's specific written consent.

TRINAMIC products are not designed nor intended for use in military or aerospace applications or environments or in automotive applications unless specifically designated for such use by TRINAMIC. TRINAMIC conveys no patent, copyright, mask work right or other trade mark right to this product. TRINAMIC assumes no liability for any patent and/or other trade mark rights of a third party resulting from processing or handling of the product and/or any other use of the product.

11.7 Collateral Documents & Tools

This product documentation is related and/or associated with additional tool kits, firmware and other items, as provided on the product page at: www.trinamic.com.



12 Revision History

12.1 Firmware Revision

Firmware Revision		
Version	Date	Description
V3.19	2016-FEB-2	First release.

Table 280: Firmware Revision

12.2 Document Revision

Document Revision		
Version	Date	Description
V1.00	2016-APR-15	First release.

Table 281: Document Revision

