

TMCM-3315 CoE Firmware Manual

Firmware Version V1.01 | Document Revision V1.01 • 2016-JUL-20

The TMCM-3315 is a three axes controller/driver module for 2-phase bipolar stepper motors with separate differential encoder and separate home and stop switch inputs for each axis. Dynamic current control, and quiet, smooth and efficient operation are combined with stealthChop™, dcStep™, stallGuard™ and coolStep™ features. The module offers four analog or digital inputs as well as four digital outputs in combination with a break chopper unit.

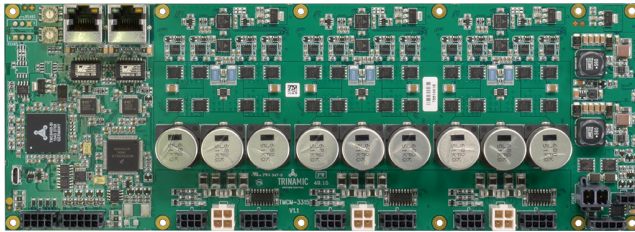

Features

- 3-Axes Stepper Motor Control
- CoE CiA-402 Drive Profile
- Closed Loop Encoder Support
- coolStep™
- dcStep™
- stallGuard2™
- stealthChop™

Applications

- Lab-Automation
- Semiconductor Handling
- Manufacturing
- Robotics
- Factory Automation
- CNC
- Laboratory Automation



Contents

1	Preface	3
1.1	General Features of this CoE Implementation	3
1.2	Abbreviations used in this Manual	4
1.3	Firmware Update	4
1.4	Trinamic's unique Features — easy to use with CoE	4
1.4.1	stallGuard2	5
1.4.2	coolStep	5
1.5	Closed-Loop Operation	6
1.5.1	Closed-Loop Parameters	7
1.5.2	Load Angle Control	8
1.5.3	Current Level Control	9
1.5.4	Field Weakening	9
1.5.5	Position Catch up	10
2	Communication	11
2.1	Reference Model	11
2.2	NMT State Machine	13
2.3	Device Model	14
2.4	Object Dictionary	15
2.4.1	Object Indices on Multi-Axis Modules	15
3	Communication area	17
3.1	Detailed object specifications	17
3.1.1	Object 1000 _h : Device Type	17
3.1.2	Object 1001 _h : Error Register	17
3.1.3	Object 1008 _h : Manufacturer Device Name	18
3.1.4	Object 1009 _h : Manufacturer Hardware Version	18
3.1.5	Object 100A _h : Manufacturer Software Version	19
3.1.6	Object 1018 _h : Identity Object	19
3.1.7	Object 1600 _h : Receive PDO Mapping Parameter	20
3.1.8	Objects 1A00 _h : Transmit PDO Mapping Parameter	21
3.1.9	Objects 1C00 _h : Sync Manager Communication Type	21
3.1.10	Objects 1C12 _h : Sync Manager 2 PDO Assignment	22
3.1.11	Objects 1C13 _h : Sync Manager 3 PDO Assignment	23
4	Manufacturer specific area	24
4.1	Objects related to coolStep	24
4.2	Detailed object specifications	27
4.2.1	Object 2000 _h : Microstep resolution	27
4.2.2	Object 2001 _h : Fullstep resolution	27
4.2.3	Object 2002 _h : Brake delay times	27
4.2.4	Object 2003 _h : Maximum current	28
4.2.5	Object 2004 _h : Standby current	29
4.2.6	Object 2005 _h : Limit switches	29
4.2.7	Object 200A _h : Enable drive delay time	30
4.2.8	Object 200B _h : Encoder parameters	30
4.2.9	Object 200C _h : Brake current feed	31
4.2.10	Object 2010 _h : Profile Start Velocity	31
4.2.11	Object 2011 _h : Profile start acceleration	32
4.2.12	Object 2012 _h : Profile break velocity	32
4.2.13	Object 2013 _h : Profile final deceleration	33
4.2.14	Object 2014 _h : Profile stop Deceleration	33



4.2.15 Object 2020 _h : Closed-loop Mode	33
4.2.16 Object 2021 _h : Correction Position P	34
4.2.17 Object 2022 _h : Maximum Correction Tolerance	34
4.2.18 Object 2027 _h : Closed-loop Beta	35
4.2.19 Object 2028 _h : Closed-loop Offset	35
4.2.20 Object 2029 _h : Current Scaler Minimum	36
4.2.21 Object 202A _h : Current Scaler Maximum	36
4.2.22 Object 202B _h : Correction Velocity P	36
4.2.23 Object 202C _h : Correction Velocity I	37
4.2.24 Object 202D _h : Correction Velocity I Clipping	37
4.2.25 Object 202E _h : Correction Velocity DV Clock	38
4.2.26 Object 202F _h : Correction Velocity DV Clipping	38
4.2.27 Object 2030 _h : Upscale Delay	38
4.2.28 Object 2031 _h : Downscale Delay	39
4.2.29 Object 2033 _h : Actual Scaling Factor	39
4.2.30 Object 2034 _h : Field Weakening Minimum Velocity	39
4.2.31 Object 2035 _h : Field Weakening Maximum Velocity	40
4.2.32 Object 2036 _h : Field Weakening	40
4.2.33 Object 204E _h : Boost Current	41
4.2.34 Object 2089 _h : Setting Delay	41
4.2.35 Object 208C _h : Velocity Dimension Index	42
4.2.36 Object 208E _h : Acceleration Dimension Index	42
4.2.37 Object 2092 _h : Chopper Blank Time	42
4.2.38 Object 2093 _h : Chopper Mode	43
4.2.39 Object 2094 _h : Chopper Hysteresis Decrement	43
4.2.40 Object 2095 _h : Chopper Hysteresis End	44
4.2.41 Object 2096 _h : Chopper Hysteresis Start	44
4.2.42 Object 2097 _h : Chopper Off Time	45
4.2.43 Object 2098 _h : Smart Energy Current Minimum	45
4.2.44 Object 2099 _h : Smart Energy Current Down Step	46
4.2.45 Object 209A _h : Smart Energy Hysteresis	46
4.2.46 Object 209B _h : Smart Energy Current Up Step	47
4.2.47 Object 209C _h : Smart Energy Hysteresis Start	47
4.2.48 Object 209D _h : Smart Energy Filter Enable	48
4.2.49 Object 209E _h : stallGuard2 Threshold	48
4.2.50 Object 20A1 _h : Short Protection Disable	49
4.2.51 Object 20A3 _h : Vsense	49
4.2.52 Object 20A4 _h : Stop on Stall	50
4.2.53 Object 20A5 _h : Smart Energy Threshold Speed	50
4.2.54 Object 2100 _h : Home Offset Display	51
4.2.55 Object 2101 _h : Actual Load Value	51
4.2.56 Object 2102 _h : Driver Error Flags	51
4.2.57 Object 2107 _h : Microstep resolution display	52
4.2.58 Object 210B _h : Step Counter	53
4.2.59 Object 2120 _h : Closed-loop Initialization Flag	53
4.2.60 Object 2700 _h : TMCL Direct Communication	54
4.2.61 Object 2701 _h : Manufacturer Specific Mode	54
4.2.62 Object 2702 _h : Device Digital Inputs	55
4.2.63 Object 2703 _h : Device Digital Outputs	55
4.2.64 Object 2704 _h : CAN Bit Rate	56
4.2.65 Object 2705 _h : Node ID	56
4.2.66 Object 2706 _h : Store	57
4.2.67 Object 2707 _h : CAN Bit Rate Load	57
4.2.68 Object 2708 _h : Node ID Load	58



4.2.69	Object 270E _h : Device Analog Inputs	58
5	Profile specific area	60
5.1	Detailed object specifications	60
5.1.1	Object 605A _h : Quick stop option code	60
5.1.2	Object 605B _h : Shutdown option code	61
5.1.3	Object 605C _h : Disable operation option code	62
5.1.4	Object 605D _h : Halt option code	62
5.1.5	Object 605E _h : Fault reaction option code	63
5.1.6	Object 6060 _h : Modes of operation	63
5.1.7	Object 6061 _h : Modes of operation	64
5.1.8	Object 606A _h : Sensor selection code	65
5.1.9	Object 608F _h : Position Encoder Resolution	65
5.1.10	Object 60FD _h : Digital Inputs	66
5.1.11	Object 6502 _h : Supported Drive Modes	66
6	Profile position mode	68
6.1	Detailed Object Specifications	68
6.1.1	Object 6040 _h : Control Word	69
6.1.2	Object 6041 _h : Status Word	70
6.1.3	Object 6062 _h : Position Demand Value	71
6.1.4	Object 6063 _h : Position Actual Internal Value	72
6.1.5	Object 6064 _h : Position Actual Internal Value	72
6.1.6	Object 6065 _h : Following Error Window	73
6.1.7	Object 6067 _h : Position Window	73
6.1.8	Object 6068 _h : Position Window Time	74
6.1.9	Object 606C _h : Velocity Actual Value	74
6.1.10	Object 607A _h : Target Position	75
6.1.11	Object 607D _h : Software Position Limit	75
6.1.12	Object 6081 _h : Profile Velocity	76
6.1.13	Object 6082 _h : End Velocity	76
6.1.14	Object 6083 _h : Profile Acceleration	77
6.1.15	Object 6084 _h : Profile Deceleration	77
6.1.16	Object 6085 _h : Quick Stop Deceleration	77
6.1.17	Object 6086 _h : Motion Profile Type	78
6.1.18	Object 60A4 _h : Profile Jerk	78
6.1.19	Object 60F2 _h : Positioning Option Code	79
6.2	How to move a Motor in pp Mode	80
7	Profile velocity mode	81
7.1	Detailed Object Specifications	81
7.1.1	Object 6040 _h : Control Word	81
7.1.2	Object 6041 _h : Status Word	82
7.1.3	Object 6062 _h : Position Demand Value	84
7.1.4	Object 6063 _h : Position Actual Internal Value	84
7.1.5	Object 6064 _h : Position Actual Internal Value	85
7.1.6	Object 6065 _h : Following Error Window	85
7.1.7	Object 606C _h : Velocity Actual Value	86
7.1.8	Object 607D _h : Software Position Limit	86
7.1.9	Object 6083 _h : Profile Acceleration	87
7.1.10	Object 6084 _h : Profile Deceleration	87
7.1.11	Object 6085 _h : Quick Stop Deceleration	87
7.1.12	Object 6086 _h : Motion Profile Type	88
7.1.13	Object 60A4 _h : Profile Jerk	88



7.1.14 Object 60FF _h : Target Velocity	89
7.2 How to move a Motor in pv Mode	89
8 Homing mode	91
8.1 Homing Methods	91
8.1.1 Homing Method 1: Homing on negative Limit Switch and Index Pulse	92
8.1.2 Homing Method 2: Homing on positive Limit Switch and Index Pulse	92
8.1.3 Homing Method 3: Homing on positive Home Switch and Index Pulse	93
8.1.4 Homing Method 5: Homing on negative Home Switch and Index Pulse	93
8.1.5 Homing Method 17, 18, 19, and 21: Homing without Index Pulse	94
8.1.6 Homing Method 33 and 34: Homing on next Index Pulse	94
8.1.7 Homing Method 35: Current position as home position	95
8.2 Detailed Object Specifications	96
8.2.1 Object 6040 _h : Control Word	96
8.2.2 Object 6041 _h : Status Word	97
8.2.3 Object 606C _h : Velocity Actual Value	98
8.2.4 Object 607C _h : Home Offset	99
8.2.5 Object 6098 _h : Homing Method	100
8.2.6 Object 6099 _h : Homing Speeds	100
8.2.7 Object 609A _h : Homing Acceleration	100
8.2.8 Object 2100 _h : Home Offset Display	101
8.3 How to start a Homing in hm Mode	101
9 Emergency Messages (EMCY)	103
10 Figures Index	105
11 Tables Index	106
12 Supplemental Directives	107
12.1 Producer Information	107
12.2 Copyright	107
12.3 Trademark Designations and Symbols	107
12.4 Target User	107
12.5 Disclaimer: Life Support Systems	107
12.6 Disclaimer: Intended Use	107
12.7 Collateral Documents & Tools	108
13 Revision History	109
13.1 Firmware Revision	109
13.2 Document Revision	109



1 Preface

This document specifies objects and modes of operation of the Trinamic TMCM-3315 stepper motor control module with CANopen-over-EtherCAT (CoE) firmware. The CoE firmware is designed to fulfill the EtherCAT version of the CANopen DS402 standards. The EtherCAT conformance has also been tested. This manual assumes that the reader is already familiar with the basics of EtherCAT and the CoE protocol (especially DS402).

If necessary it is always possible to turn the module into a TMCL module by loading the TMCM-3315 TMCL firmware again through the USB interface, with the help of the firmware update function of the TMCL-IDE 3.0.

1.1 General Features of this CoE Implementation

Main Characteristics

- Communication according to EtherCAT standards
- Protocols: CoE, FoE

SDO Communication

- 1 server
- Expedited transfer
- Segmented transfer
- No block transfer

PDO Communication

- Producer
- Consumer
- RPDOs
 - Dynamic mapping with max. 9 mapping entries.
 - Default mappings: manufacturer specific.
- TPDOs
 - Dynamic mapping with max. 9 mapping entries.
 - Default mappings: manufacturer specific.

Sync managers

- Sync manager 0: receive mailbox used for SDO communication
- Sync manager 1: send mailbox used for SDO communication
- Sync manager 2: process data output (used for TPDO)
- Sync manager 3: process data input (used for RPDO)

Further Characteristics

- Emergency: producer



1.2 Abbreviations used in this Manual

Abbreviations	
CAN	Controller area network
CoE	CANopen over EtherCAT
CHGND	chassis ground / earth ground
COB	Communication object
FoE	File transfer over EtherCAT
FSA	Finite state automaton
FSM	Finite state machine
NMT	Network management
ID	Identifier
LSB	Least significant bit
MSB	Most significant bit
PDO	Process data object
PDS	Power drive system
RPDO	Receive process data object
SDO	Service data object
TPDO	Transmit process data object
EMCY	Emergency object
rw	Read and write
ro	Read only
hm	Homing mode
pp	Profile position mode
pv	Profile velocity mode
vm	Velocity mode

Table 1: Abbreviations used in this Manual

1.3 Firmware Update

The software running on the microprocessor consists of two parts, a boot loader and the CANopen firmware itself. Whereas the boot loader is installed during production and testing at TRINAMIC and remains untouched throughout the whole lifetime, the CANopen firmware can easily be updated by the user. The new firmware can be loaded into the module via the firmware update function of the TMCL-IDE, using the USB interface of the module.

1.4 Trinamic's unique Features — easy to use with CoE



1.4.1 stallGuard2

stallGuard2 is a high-precision sensorless load measurement using the back EMF of the coils. It can be used for stall detection as well as other uses at loads below those which stall the motor. The stallGuard2 measurement value changes linearly over a wide range of load, velocity, and current settings. At maximum motor load, the value reaches zero or is near zero. This is the most energy-efficient point of operation for the motor.

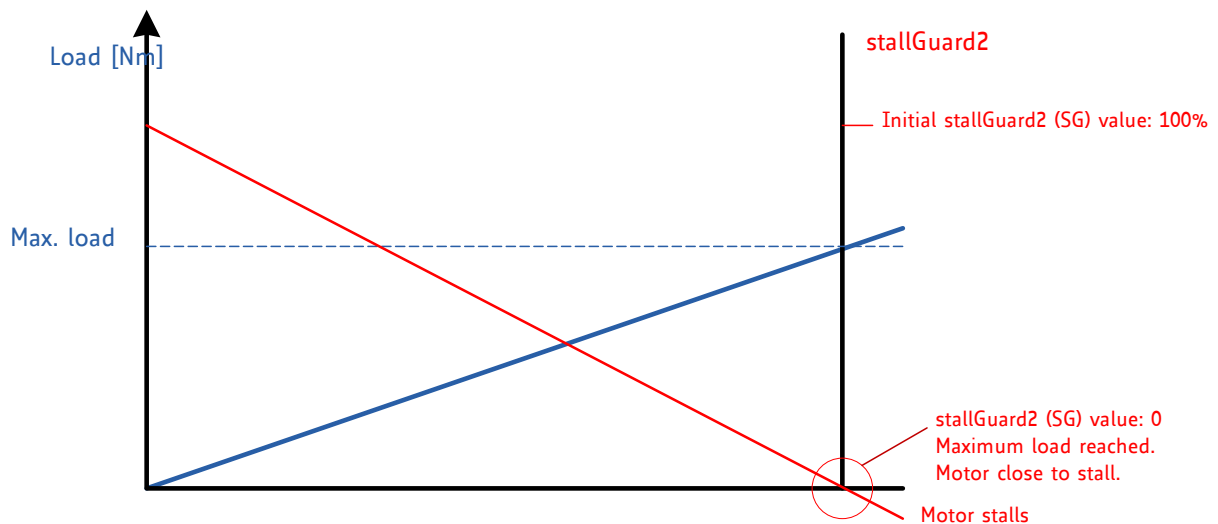

Figure 1: stallGuard2 Load Measurement as a Function of Load

1.4.2 coolStep

coolStep is a load-adaptive automatic current scaling based on the load measurement via stallGuard2 adapting the required current to the load. Energy consumption can be reduced by as much as 75%. coolStep allows substantial energy savings, especially for motors which see varying loads or operate at a high duty cycle. Because a stepper motor application needs to work with a torque reserve of 30% to 50%, even a constant-load application allows significant energy savings because coolStep automatically enables torque reserve when required. Reducing power consumption keeps the system cooler, increases motor life, and allows cost reduction.



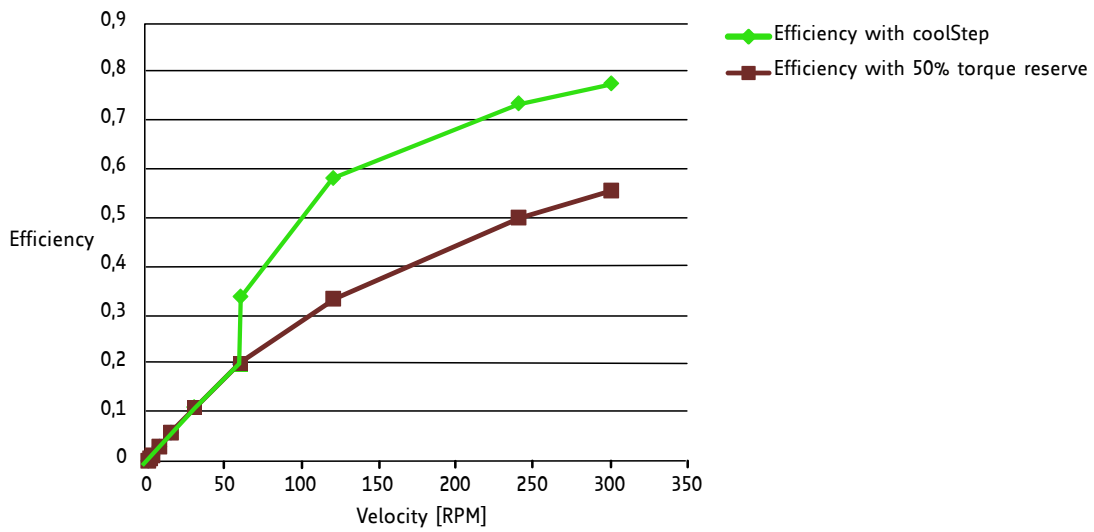

Figure 2: Energy Efficiency Example with coolStep

1.5 Closed-Loop Operation

Together with an external ABN encoder it is possible to operate each axis of the TMCM-3315 as a closed-loop stepper system. Before enabling this feature, some parameters have to be set. The following table shows which objects should be set to which values in order to make closed-loop work. In this example we assume that an 1.8° motor is used together with a 10000cpr encoder.



Closed-Loop Example Settings			
Parameter	Object	Value	Comment
Maximum current	2003 _h	85	Set maximum motor current to 1 A
Standby current	2004 _h	10	Set standby current to 0.1 A
Encoder resolution	608F _h /1	10000	Set encoder resolution to 10000cpr
Field weakening minimum velocity	2034 _h	300000	Set gamma Vmin
Field weakening maximum velocity	2035 _h	1600000	Set gamma Vmax
Field weakening	2036 _h	255	(default value)
Closed loop beta	2027 _h	255	Beta (default value)
Current scaler minimum	2029 _h	50	
Current scaler maximum	202A _h	255	
Maximum correction tolerance	2022 _h	255	
Upscale delay	2030 _h	1000	
Downscale delay	2031 _h	10000	
Correction velocity P	202B _h	3000	
Correction velocity I	202C _h	20	
Correction velocity I clipping	202D _h	2000	
Correction velocity DV clock	202E _h	0	
Correction velocity DV clipping	202F _h	100000	
Correction position P	2021 _h	65536	

Table 2: Closed-Loop Example Settings

After these settings have been made, switch the state machine to OPERATIONAL (using the control word). Then, turn on closed-loop operation by setting object 2020_h to 1. Now, read object 2120_h until its value is 1 (closed-loop initialization finished).

1.5.1 Closed-Loop Parameters

The closed-loop operation of the TMCM-3315 is based on Trinamic's closed-loop hardware motion controller IC TMC4361.

The 2-phase closed-loop control of the TMCM-3315 follows a different approach than PID control cascades to consider stepper motor driver characteristics. The ramp generator which assigns target and velocity is independent of the position control (commutation angle control) which is also independent of the current control. The closed-loop control scheme is depicted in the following picture.



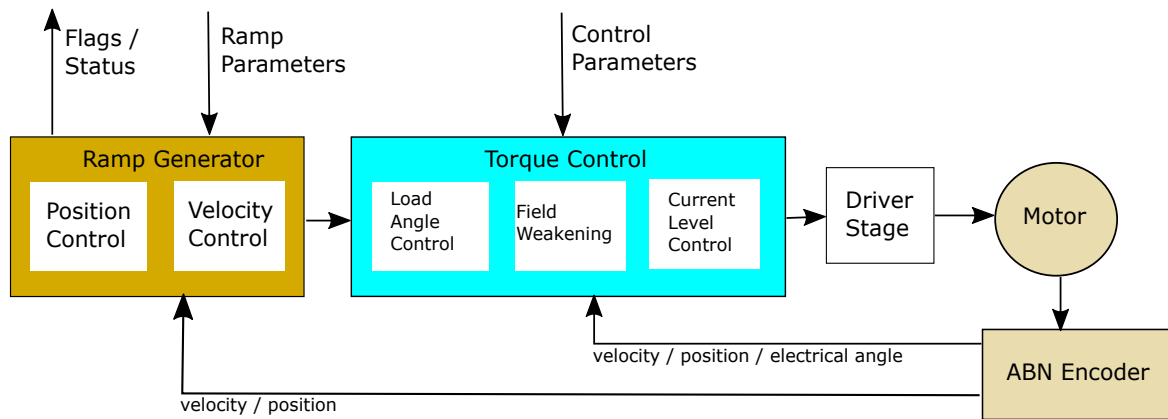

Figure 3: Closed-Loop Control Scheme

Load angle control and current level control will be executed in parallel.

1.5.2 Load Angle Control

As typical for stepper motor drivers, phase currents will be assigned directly to the motor drivers. This results in a current vector which should be followed by the rotor. The rotor position will be directly sampled by encoder feedback. The closed-loop motor control monitors the resulting load angle (deviation between driver stage current vector and encoder angle). Further on, the direction of the current vector will track the rotor position if the load angle should impend to exceed a certain limit. The result is a load angle which will never exceed the given limit and as a result no step loss will occur. Thus, the current vector will follow an overpowered load until the load is reduced.

Figure 4 shows the parameters which limit the load angle.

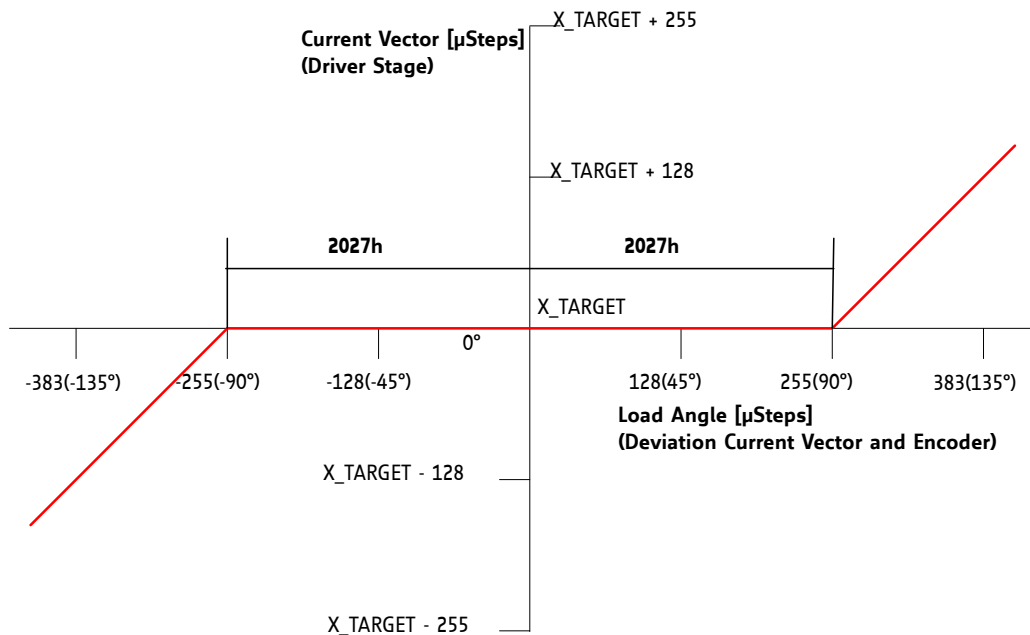

Figure 4: Load Angle Control Parameter



1.5.3 Current Level Control

Parallel to the load angle control the TMCM-3315 controls the motor current level (current vector amplitude) depending on the load angle to save energy during no or light load. Figure 5 gives an overview of the current control parameters.

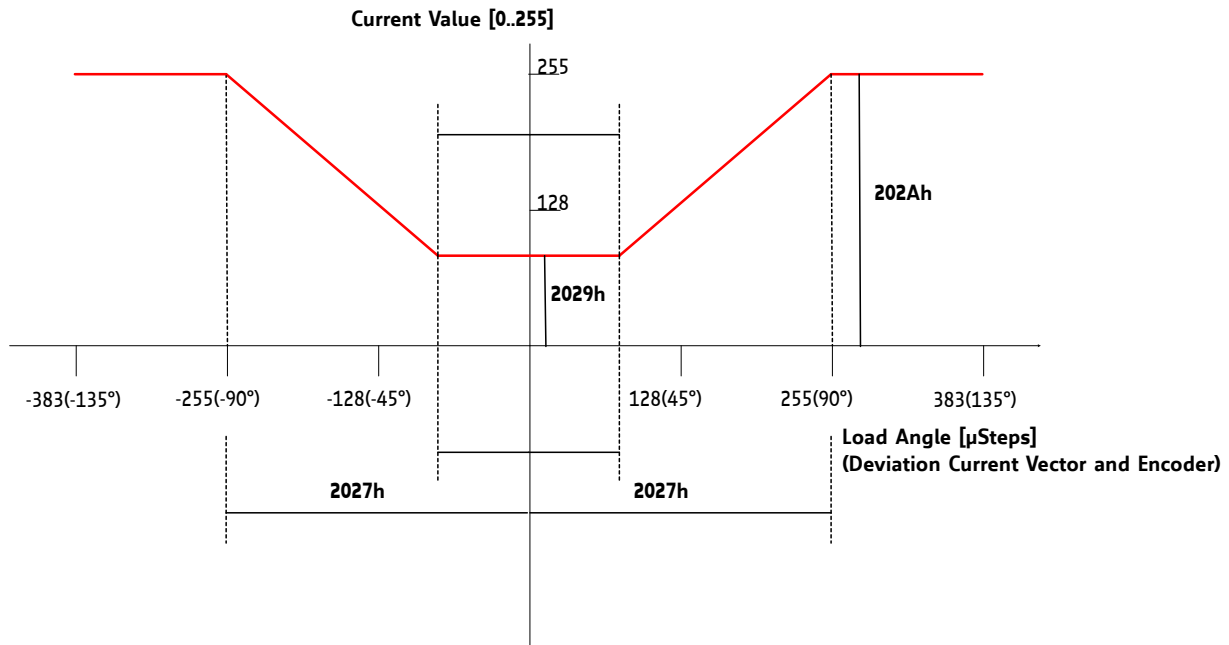

Figure 5: Current Level Control

- Object 2027_h: Closed-loop beta.
- Object 2029_h: Minimum closed-loop current scaler.
- Object 202A_h: Maximum closed-loop current scaler.

Objects 2030_h and 2031_h set up the delay which defines how fast the actual current will be increased or decreased and will follow the red marked graph.

1.5.4 Field Weakening

With every stepper motor the TMCM-3315 will reach a velocity where it is not possible to maintain the target motor current due to the motor back EMF. Above this velocity load angle (2027_h, default 90°) and current level control will reach their maximum. To drive the stepper motor faster the back EMF must be compensated by commutating the stepper motor with a commutation angle between 90° and 180°. The parameters for field weakening are described in figure 6.



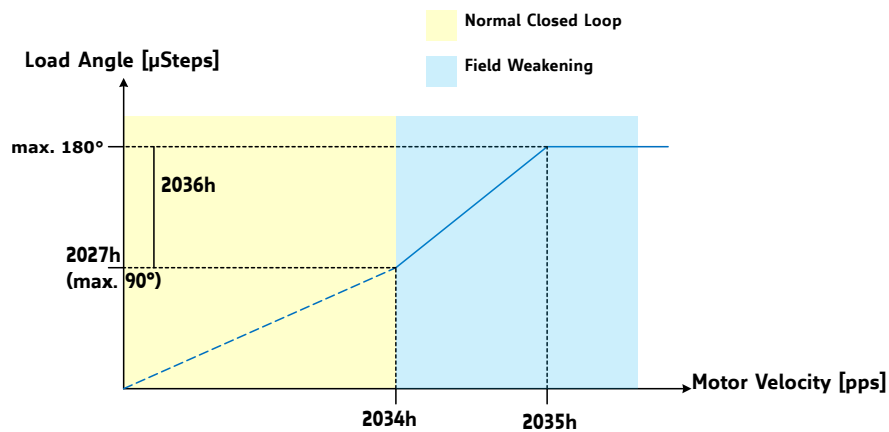

Figure 6: Field Weakening

- Object 2027_h: Closed-loop beta.
- Object 2036_h: Field weakening (closed-loop gamma).
- Object 2034_h: Field weakening minimum velocity (gamma Vmin).
- Object 2035_h: Field weakening maximum velocity (gamma Vmax).

1.5.5 Position Catch up

The TMCM-3315 includes a special feature for closed-loop positioning. Positioning parameters like velocity and acceleration will be calculated to reach a position in a dedicated time. If the target trapezoidal ramp cannot be maintained due to high load peaks the TMCM-3315 includes a special position catch-up mode to ensure that the position will still be reached in time if possible.

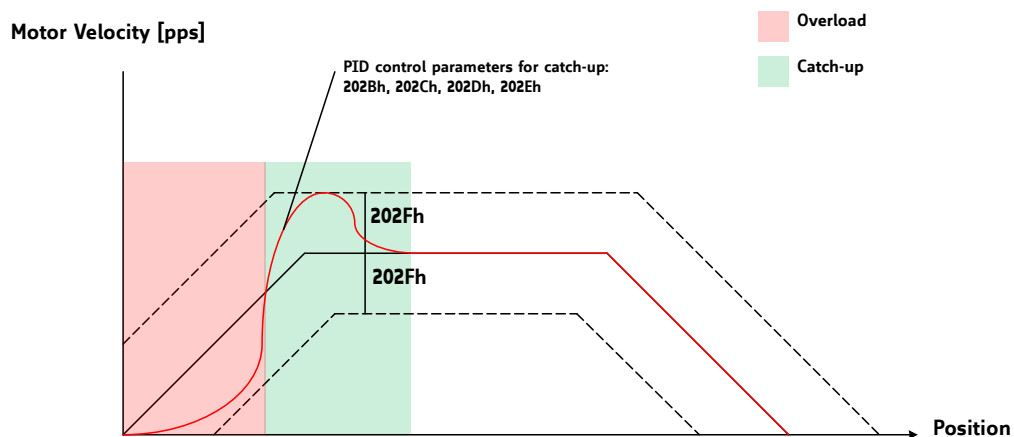

Figure 7: Position Catch up



2 Communication

2.1 Reference Model

The application layer comprises a concept to configure and communicate real-time-data as well as the mechanisms for synchronization between devices. The functionality which the application layer offers to an application is logically divided over different service data objects (SDO) in the application layer. A service object offers a specific functionality and all the related services.

Applications interact by invoking services of a service object in the application layer. To realize these services this object exchanges data via the EtherCAT with peer service object(s) using a protocol.

The application and the application layer interact with service primitives.

Service Primitives	
Primitive	Definition
Request	Issued by the application to the application layer to request a service.
Indication	Issued by the application layer to the application to report an internal event detected by the application layer or indicate that a service is requested.
Response	Issued by the application to the application layer to respond to a previous received indication.
Confirmation	Issued by the application layer to the application to report the result of a previously issued request.

Table 3: Service Primitives

A service type defines the primitives that are exchanged between the application layer and the cooperating applications for a particular service of a service object. Unconfirmed and confirmed services are collectively called remote services.



Service Types	
Type	Definition
Local service	Involves only the local service object. The application issues a request to its local service object that executes the requested service without communicating with peer service object(s).
Unconfirmed service	Involves one or more peer service objects. The application issues a request to its local service object. This request is transferred to the peer service object(s) that each passes it to their application as an indication. The result is not confirmed back.
Confirmed service	Can involve only one peer service object. The application issues a request to its local service object. This request is transferred to the peer service object that passes it to the other application as an indication. The other application issues a response that is transferred to the originating service object that passes it as a confirmation to the requesting application.
Provider initiated service	Involves only the local service object. The service object (being the service provider) detects an event not solicited by a requested service. This event is then indicated to the application.

Table 4: Service Types



2.2 NMT State Machine

The finite state machine (FSM) or simply state machine is a model of behavior composed of a finite number of states, transitions between those states, and actions. It shows which way the logic runs when certain conditions are met.

Starting and resetting the device is controlled via the state machine. The NMT state machine consists of the states shown in figure 8.

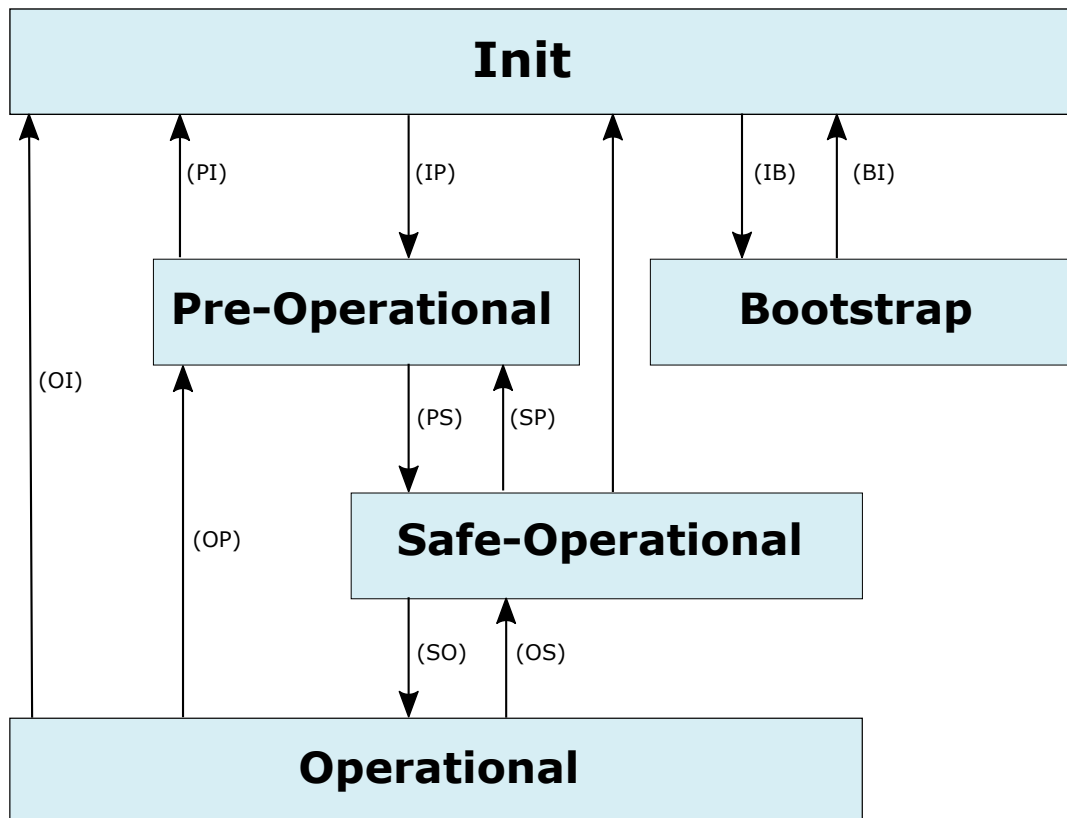

Figure 8: NMT State Machine

After power-on or reset the device enters the Initialization (**INIT**) state.

The master can then switch the device to Pre-Operational (**PRE-OP**) state. In this state, only SDO communication is possible. PDO communication is not possible.

In Safe-Operational (**SAFE-OP**) state, also PDO communication is possible. Inputs can be read, but outputs cannot be switched and the motor cannot be run.

In Operational (**OP**) state, all features of the module can be used. PDO communication is possible, outputs can be switched and the motor can be used. During Operational state the device can use all supported communication objects.

When switching from Operational to Safe-Operational state the motor will be stopped if it has been running. When the EtherCAT connection is lost during Operational state the device will also automatically switch to



Safe-Operational state.

The Bootstrap (**BOOT**) state is used for firmware updates via FoE. Before FoE can be used the device has to be switched to this state.

2.3 Device Model

A CoE device mainly consists of the following parts:

- *Communication*: This function unit provides the communication objects and the appropriate functionality to transport data items via the underlying network structure.
- *Object dictionary*: The object dictionary is a collection of all the data items which have an influence on the behavior of the application objects, the communication objects and the state machine used on this device.
- *Application*: The application comprises the functionality of the device with respect to the interaction with the process environment.

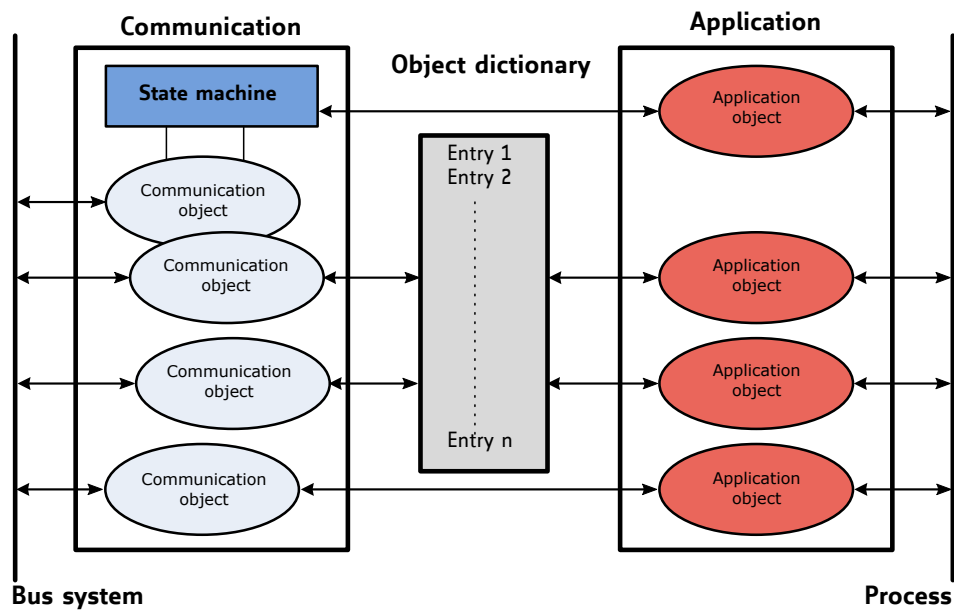

Figure 9: Device Model



2.4 Object Dictionary

The most important part of a device profile is the object dictionary description. The object dictionary is essentially a grouping of objects accessible via the network in an ordered pre-defined fashion. Each object within the dictionary is addressed using a 16-bit index. The overall layout of the standard object dictionary is shown in table 5:

Object Dictionary	
Index	Object
0000 _h	Not used.
0001 _h – 001F _h	Static data types.
0020 _h – 003F _h	Complex data types.
0040 _h – 005F _h	Manufacturer specific complex data types.
0060 _h – 007F _h	Device profile specific static data types.
0080 _h – 009F _h	Device profile specific complex data types.
00A0 _h – 0FFF _h	Reserved for further use.
1000 _h – 1FFF _h	Communication profile area.
2000 _h – 5FFF _h	Manufacturer specific profile area.
6000 _h – 9FFF _h	Standardized device profile area.
A000 _h – BFFF _h	Standardized interface profile area.
C000 _h – FFFF _h	Reserved for further use.

Table 5: Object Dictionary

The communication profile area at indices 1000_h through 1FFF_h contains the communication specific parameters for the CAN network. These entries are common to all devices.

The manufacturer segment at indices 2000_h through 5FFF_h contains manufacturer specific objects. These objects control the special features of the Trinamic TMCM-3315 motion control device.

The standardized device profile area at indices 6000_h through 9FFF_h contains all data objects common to a class of devices that can be read or written via the network. They describe the device parameters and the device functionality of the device profile.

2.4.1 Object Indices on Multi-Axis Modules

On a multi-axis module like the TMCM-3315 each object in the manufacturer area and each object in the profile specific area is available for each motor. In this manual, only the object indices for motor #0 are shown. The objects for the other motors can be accessed by adding offsets to the object indices:

- Add an offset of $motor_number \cdot 200_h$ to the index of a manufacturer specific object to get its index for other motors.
- Add an offset of $motor_number \cdot 800_h$ to the index of a profile specific object to get its index for other motors.



For example, the control word for motor #1 would be 6840_h (instead of 6040_h for motor #0), and the microstep resolution of motor #1 would be 2200_h for motor #1 (instead of 2000_h for motor #0).

Multi-Axis Object Indices		
Motor	Manufacturer area	Profile area
Motor #0	2000 _h – 21FF _h	6000 _h – 67FF _h
Motor #1	2200 _h – 23FF _h	6800 _h – 6FFF _h
Motor #2	2400 _h – 25FF _h	7000 _h – 77FF _h

Table 6: Multi-Axis Object Indices



3 Communication area

The communication area contains all objects that define the communication parameters of the CoE device according to the EtherCAT standard.

3.1 Detailed object specifications

3.1.1 Object 1000_h: Device Type

This object contains information about the device type. The object 1000_h describes the type of device and its functionality. It is composed of a 16-bit field which describes the device profile that is used and a second 16-bit field which provides additional information about optional functionality of the device.

Object Description			
Index	Name	Object Type	Data Type
1000 _h	Device type	Variable	UNSIGNED32

Table 7: Object Description (1000_h)

Entry Description				
Sub-index	Access	PDO Mapping	Value Range	Default Value
0	ro	no	UNSIGNED32	FFFC0192 _h

Table 8: Entry Description (1000_h)

3.1.2 Object 1001_h: Error Register

This object contains information about the device type. The object 1000_h describes the type of device and its functionality. It is composed of a 16-bit field which describes the device profile that is used and a second 16-bit field which provides additional information about optional functionality of the device.

Object Description			
Index	Name	Object Type	Data Type
1001 _h	Error register	Variable	UNSIGNED8

Table 9: Object Description (1001_h)

Entry Description				
Sub-index	Access	PDO Mapping	Value Range	Default Value
0	ro	no	UNSIGNED8	0

Table 10: Entry Description (1001_h)



Error Register Bits	
Bit	Definition
0	Generic error
1	Current
2	Voltage
3	Temperature
4	Communication error
5	Device profile specific
6	Reserved (always 0)
7	Manufacturer specific

Table 11: Error Register Bits

3.1.3 Object 1008_h: Manufacturer Device Name

This object contains the manufacturer device name.

Object Description			
Index	Name	Object Type	Data Type
1008 _h	Manufacturer Device Name	Variable	Visible String

Table 12: Object Description (1008_h)

Entry Description				
Sub-index	Access	PDO Mapping	Value Range	Default Value
0	ro	no	—	TMCM-3315

Table 13: Entry Description (1008_h)

3.1.4 Object 1009_h: Manufacturer Hardware Version

This object contains the hardware version description.

Object Description			
Index	Name	Object Type	Data Type
1009 _h	Manufacturer Hardware Version	Variable	Visible String

Table 14: Object Description (1009_h)



Entry Description				
Sub-index	Access	PDO Mapping	Value Range	Default Value
0	ro	no	—	Depends on device, e.g. 1.0.

Table 15: Entry Description (1009_h)

3.1.5 Object 100A_h: Manufacturer Software Version

This object contains the software version description.

Object Description			
Index	Name	Object Type	Data Type
100A _h	Manufacturer Software Version	Variable	Visible String

Table 16: Object Description (100A_h)

Entry Description				
Sub-index	Access	PDO Mapping	Value Range	Default Value
0	ro	no	—	Depends on device, e.g. 1.0.

Table 17: Entry Description (100A_h)

3.1.6 Object 1018_h: Identity Object

The object 1018_h contains general information about the device:

- The vendor ID (sub-index 01_h) contains a unique value allocated to each manufacturer. The vendor ID of Trinamic is 286_h.
- The manufacturer specific product code (sub-index 2_h) identifies a specific device version.
- The manufacturer specific revision number (sub-index 3_h) consists of a major revision number and a minor revision number.

Object Description			
Index	Name	Object Type	Data Type
1018 _h	Identity object	Record	Identity

Table 18: Object Description (1018_h)

Entry Description					
Sub-index	Description	Access	PDO Mapping	Value Range	Default Value
00 _h	Number of entries	ro	no	0...3	3
01 _h	Vendor ID	ro	no	UNSIGNED32	0286 _h
02 _h	Product code	ro	no	UNSIGNED32	3315
03 _h	Revision number	ro	no	UNSIGNED32	e.g. 20003 _h for version 2.3

Table 19: Entry Description (1018_h)

3.1.7 Object 1600_h: Receive PDO Mapping Parameter

This object contains the mapping parameters for the RPDO the device is able to receive. The sub-index 00_h contains the number of valid entries within the mapping record. This number of entries is also the number of the application variables which shall be received with the corresponding RPDO. The sub-indices from 01_h to the number of entries contain the information about the mapped application variables. These entries describe the PDO contents by their index, sub-index and length.

Object Description			
Index	Name	Object Type	Data Type
1600 _h	Receive PDO mapping parameter	RECORD	PDO Mapping

Table 20: Object Description (1600_h)

Entry Description				
Sub-index	Description	Access	Value Range	Default Value
00 _h	Number of mapped application objects in PDO	rw	0...9	Index 1600 _h : 4
01 _h	Mapping entry 1	rw	UNSIGNED32	60400010 _h
02 _h	Mapping entry 3	rw	UNSIGNED32	607A0020 _h
03 _h	Mapping entry 4	rw	UNSIGNED32	60710010 _h
04 _h	Mapping entry 5	rw	UNSIGNED32	60FF0020 _h
05 _h	Mapping entry 2	rw	UNSIGNED32	0 _h
06 _h	Mapping entry 6	rw	UNSIGNED32	0 _h
07 _h	Mapping entry 7	rw	UNSIGNED32	0 _h
08 _h	Mapping entry 8	rw	UNSIGNED32	0 _h
09 _h	Mapping entry 9	rw	UNSIGNED32	0 _h

Table 21: Entry Description (1600_h)

3.1.8 Objects 1A00_h: Transmit PDO Mapping Parameter

This object contains the mapping parameters for the TPDO the device is able to transmit. The sub-index 00_h contains the number of valid entries within the mapping record. This number of entries is also the number of the application variables which shall be transmitted with the corresponding TPDO. The sub-indices from 01_h to the number of entries contain the information about the mapped application variables. These entries describe the PDO contents by their index, sub-index and length.

Object Description			
Index	Name	Object Type	Data Type
1A00 _h	Transmit PDO mapping parameter	RECORD	PDO Mapping

Table 22: Object Description (1A00_h)

Entry Description				
Sub-index	Description	Access	Value Range	Default Value
00 _h	Number of mapped application objects in PDO	rw	0...9	6
01 _h	Mapping entry 1	rw	UNSIGNED32	60410010 _h
02 _h	Mapping entry 2	rw	UNSIGNED32	60610008 _h
03 _h	Mapping entry 3	rw	UNSIGNED32	60640020 _h
04 _h	Mapping entry 4	rw	UNSIGNED32	60770010 _h
05 _h	Mapping entry 5	rw	UNSIGNED32	606C0020 _h
06 _h	Mapping entry 6	rw	UNSIGNED32	60FD0020 _h
07 _h	Mapping entry 7	rw	UNSIGNED32	0 _h
08 _h	Mapping entry 8	rw	UNSIGNED32	0 _h
09 _h	Mapping entry 9	rw	UNSIGNED32	0 _h

Table 23: Entry Description (1A00_h)

3.1.9 Objects 1C00_h: Sync Manager Communication Type

This object describes the communication types of the EtherCAT sync managers. The types of the first four sync managers are normally fixed and should not be changed. Sync managers can have the following for communication types:



Sync Manager Communication Types	
Type	Description
1	Mailbox receive
2	Mailbox send
3	Process data input
4	Process data output

Table 24: Sync Manager Communication Types

Object Description			
Index	Name	Object Type	Data Type
1C00 _h	Sync manager communication type	RECORD	UNSIGNED8

Table 25: Object Description (1C00_h)

Entry Description				
Sub-index	Description	Access	Value Range	Default Value
00 _h	Number of entries	rw	0...3	4
01 _h	Communication type sync manager 1	rw	UNSIGNED8	1
02 _h	Communication type sync manager 2	rw	UNSIGNED8	2
03 _h	Communication type sync manager 3	rw	UNSIGNED8	3
04 _h	Communication type sync manager 4	rw	UNSIGNED8	4

Table 26: Entry Description (1C00_h)

3.1.10 Objects 1C12_h: Sync Manager 2 PDO Assignment

This object contains the index of the PDO definition object that is assigned to sync manager 2. Normally, the RPDO objects are assigned to sync manager 2. Under most circumstances there is no need to change this setting.

Object Description			
Index	Name	Object Type	Data Type
1C12 _h	Sync manager 2 PDO assignment	RECORD	PDO assignment

Table 27: Object Description (1C12_h)



Entry Description				
Sub-index	Description	Access	Value Range	Default Value
00 _h	Number of assigned PDOs	rw	0...1	1
01 _h	PDO mapping index of assigned RPDO	rw	UNSIGNED16	1600 _h

Table 28: Entry Description (1C12_h)

3.1.11 Objects 1C13_h: Sync Manager 3 PDO Assignment

This object contains the index of the PDO definition object that is assigned to sync manager 3. Normally, the TPDO objects are assigned to sync manager 3. Under most circumstances there is no need to change this setting.

Object Description			
Index	Name	Object Type	Data Type
1C13 _h	Sync manager 3 PDO assignment	RECORD	PDO assignment

Table 29: Object Description (1C13_h)

Entry Description				
Sub-index	Description	Access	Value Range	Default Value
00 _h	Number of assigned PDOs	rw	0...1	1
01 _h	PDO mapping index of assigned TPDO	rw	UNSIGNED16	1A00 _h

Table 30: Entry Description (1C13_h)

4 Manufacturer specific area

The manufacturer segment contains manufacturer specific objects. These objects control the special features of the Trinamic Motion Control device TMC3315.

i Info

This section of the manual only shows the object indices for motor #0. Of course the same objects are also available for the other motors. For the other motors, add an offset of $motor_number \cdot 200_h$ to the object index. So for example the microstep resolution (object 2000_h for motor #0) can be accessed as object 2200_h for motor #1 and as object 2400_h for motor #2. Please see also section 2.4.1.

Multi-axis Object Indices	
Motor	Object Index Range
Motor #0	$2000_h - 21FF_h$
Motor #1	$2200_h - 23FF_h$
Motor #2	$2400_h - 25FF_h$

Table 31: Multi-axis Object Indices (Manufacturer specific Area)

4.1 Objects related to coolStep

Figure 10 shows an overview of the coolStep related objects for motor #0. Please bear in mind that the figure only shows one example for a drive. There are objects which concern the configuration of the current. Other objects are for velocity regulation and for time adjustment. The coolStep feature is sometimes also called smartEnergy.

The following adjustments have to be made:

- Thresholds for current and velocity have to be identified and set.
- The stallGuard2 feature has to be adjusted and enabled.
- The reduction or increasing of the current in the coolStep area (depending on the load) has to be configured.



coolStep™ adjustment points and thresholds

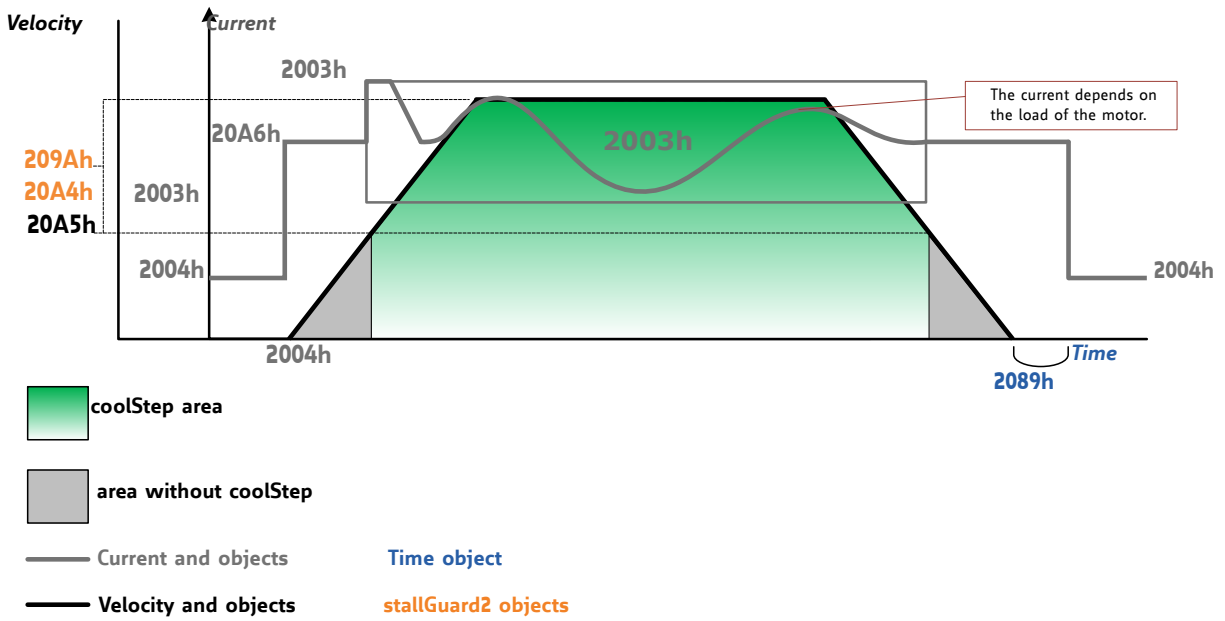

Figure 10: coolStep Adjustment Points and Thresholds



coolStep Adjustment Objects		
Object	Name	Description
2003 _h	Absolute maximum current	The maximum value is 255. This value means 100% of the maximum current of the module. The current adjustment is within the range 0...255 and can be adjusted in 32 steps (0...255 divided by eight; step 0 = 0...7, step 1 = 8...15 and so on). The most important motor setting, since too high values might cause motor damage!
2004 _h	Standby current	The current limit two seconds after the motor has stopped.
2098 _h	smartEnergy current minimum	Sets the lower motor current limit for coolStep operation by scaling the run current (object 2003 _h) value. This can be: 0: for 1/2 of the run current 1: for 1/4 of the run current
2099 _h	smartEnergy current down step	Sets the speed of current decrement when the stallGuard reading is above the upper threshold. 0: slow decrement 3: fast decrement
209B _h	smartEnergy current up step	Sets the current increment step when the stallGuard below the lower threshold. 0: slow increment 3: fast increment / fast reaction to rising load
209A _h	smartEnergy hysteresis	Sets the distance between the lower and the upper threshold for stallGuard2 reading. Above the upper threshold the motor current becomes decreased.
20A4 _h	Stop on stall	Below this speed the motor will not be stopped. Above this speed the motor will stop in case stallGuard2 load value reaches zero.
20A5 _h	smartEnergy threshold speed.	Above this speed coolStep becomes enabled.
2089 _h	Standby delay	Standstill period before the current is changed down to standby current. The standard value is 200 which is 2 seconds.

Table 32: coolStep related Objects



4.2 Detailed object specifications

4.2.1 Object 2000_h: Microstep resolution

This object sets the microstep resolution of the drive. A value of 8 selects 256 (2^8) microsteps per full step.

Object Description			
Index	Name	Object Type	Data Type
2000 _h	Microstep Resolution	Variable	UNSIGNED8

Table 33: Object Description (2000_h)

Entry Description				
Sub-index	Access	PDO Mapping	Value Range	Default Value
0	rw	no	0...8	8

Table 34: Entry Description (2000_h)

4.2.2 Object 2001_h: Fullstep resolution

This object sets the fullstep resolution of the motor connected to the drive. Its default value is 200 because most motors are 1.8° motors.

Object Description			
Index	Name	Object Type	Data Type
2001 _h	Motor full step resolution	Variable	UNSIGNED16

Table 35: Object Description (2001_h)

Entry Description				
Sub-index	Access	PDO Mapping	Value Range	Default Value
0	rw	no	0...65535	200

Table 36: Entry Description (2001_h)

4.2.3 Object 2002_h: Brake delay times

With this object the delay times for applying and releasing an (optional) brake can be defined. Please see also object 200Ah for an additional delay between enabling the power stage and releasing the brake. Both times are given in ms.



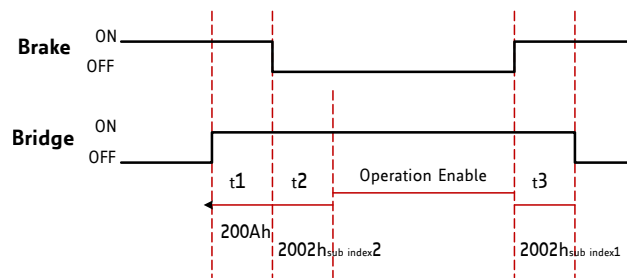

Figure 11: Brake Output Timing

Object Description			
Index	Name	Object Type	Data Type
2002 _h	Brake delay times	Array	UNSIGNED16

Table 37: Object Description (2002_h)

Entry Description					
Sub-index	Description	Access	PDO Mapping	Value Range	Default Value
1	Time between applying brake / disabling power stage	rw	no	0...65535	0
2	Time between releasing brake / switching the state machine to operational	rw	no	0..65535	0

Table 38: Entry Description (2002_h)

4.2.4 Object 2003_h: Maximum current

This object defines the current used when the motor is moving. A value of 255 means 100% of the maximum current of the drive.

Object Description			
Index	Name	Object Type	Data Type
2003 _h	Maximum current	Variable	UNSIGNED8

Table 39: Object Description (2003_h)

Entry Description				
Sub-index	Access	PDO Mapping	Value Range	Default Value
0	rw	no	0...255	128

Table 40: Entry Description (2003_h)



4.2.5 Object 2004_h: Standby current

This object defines the current used when the motor is standing (two seconds after the last move). A value of 255 means 100% of the maximum current of the drive.

Object Description			
Index	Name	Object Type	Data Type
2004 _h	Maximum current	Variable	UNSIGNED8

Table 41: Object Description (2004_h)

Entry Description				
Sub-index	Access	PDO Mapping	Value Range	Default Value
0	rw	no	0...255	8

Table 42: Entry Description (2004_h)

4.2.6 Object 2005_h: Limit switches

This object defines which limit switches are to be used. Bit 0 stands for the left and bit 1 stands for the right limit switch. If a bit is set, the corresponding limit switch will not be used. So this object has to be set to the value 3 if limit switches are not connected. The object can only be written when the drive is in the SWITCHED_ON_DISABLED state (but is always readable).

The limit switches can also be inverted using bit 2 and bit 3:

- Bit 2 inverts the left limit switch
- Bit 3 inverts the right limit switch

Object Description			
Index	Name	Object Type	Data Type
2005 _h	Limit switches	Variable	UNSIGNED32

Table 43: Object Description (2005_h)

Entry Description				
Sub-index	Access	PDO Mapping	Value Range	Default Value
0	rw	no	0...63	0

Table 44: Entry Description (2005_h)



Bit Definitions	
Bit	Definition
0	Left limit switch deactivated, if set.
1	Right limit switch deactivated, if set.
2	Left limit switch inverted, if set.
3	Right limit switch inverted, if set.
4	Home switch deactivated, if set.
5	Home switch inverted, if set.

Table 45: Bit Definitions (2005_h)

4.2.7 Object 200A_h: Enable drive delay time

This is an additional delay time (in milliseconds) between enabling the power stage and releasing the brake. It can be used to prevent the brake from being released too early (before the hold current in the motor has been reached). Please see also object 4.2.3.

Object Description			
Index	Name	Object Type	Data Type
200A _h	Enable drive delay time	Variable	UNSIGNED16

Table 46: Object Description (200A_h)

Entry Description				
Sub-index	Access	PDO Mapping	Value Range	Default Value
0	rw	no	0...65535	0

Table 47: Entry Description (200A_h)

4.2.8 Object 200B_h: Encoder parameters

This object defines encoder parameters. These are the polarity of the encoder null channel, the direction of rotation (set it to 1 if the direction is reversed compared to the motor) and if the position is to be initialized with the encoder position. It is only writable in SWITCHED_ON_DISABLED state.

Object Description			
Index	Name	Object Type	Data Type
200B _h	Encoder parameters	Array	UNSIGNED8

Table 48: Object Description (200B_h)

Entry Description					
Sub-index	Description	Access	PDO Mapping	Value Range	Default Value
1	Null channel polarity	rw	no	0/1	0
2	Direction of rotation	rw	no	0/1	0
3	Initialize position	rw	no	0/1	1

Table 49: Entry Description (200B_h)

4.2.9 Object 200C_h: Brake current feed

This object configures how much current has to be fed into the brake to apply and to release it. 0 means 0 (the module). In most cases it is needed to feed current into the brake to release it. Setting both values to 0 disables the automatic brake control. This object is only writable in SWITCHED_ON_DISABLED state.

Object Description			
Index	Name	Object Type	Data Type
200C _h	Brake current feed	Array	UNSIGNED8

Table 50: Object Description (200C_h)

Entry Description					
Sub-index	Description	Access	PDO Mapping	Value Range	Default Value
1	Apply current	rw	no	0...255	0
2	Release current	rw	no	0...255	0

Table 51: Entry Description (200C_h)

4.2.10 Object 2010_h: Profile Start Velocity

This object contains the velocity with which a positioning ramp will be started.

Object Description			
Index	Name	Object Type	Data Type
2010 _h	Profile Start Velocity	Variable	UNSIGNED32

Table 52: Object Description (2010_h)

Entry Description				
Sub-index	Access	PDO Mapping	Value Range	Default Value
0	rw	no	0...268435455	0

Table 53: Entry Description (2010_h)

4.2.11 Object 2011_h: Profile start acceleration

This object contains the acceleration value used for ramping up from the start velocity (object 2011_h, see section 4.2.10) to the velocity V1 (object (h)2012), see section 4.2.12).

Object Description			
Index	Name	Object Type	Data Type
2011 _h	Profile A1	Variable	UNSIGNED32

Table 54: Object Description (2011_h)

Entry Description				
Sub-index	Access	PDO Mapping	Value Range	Default Value
0	rw	no	0...16777215	0

Table 55: Entry Description (2011_h)

4.2.12 Object 2012_h: Profile break velocity

This object contains the velocity used for the first segment of a positioning ramp.

Object Description			
Index	Name	Object Type	Data Type
2012 _h	Profile V1	Variable	UNSIGNED32

Table 56: Object Description (2012_h)

Entry Description				
Sub-index	Access	PDO Mapping	Value Range	Default Value
0	rw	no	06777215	0

Table 57: Entry Description (2012_h)

4.2.13 Object 2013_h: Profile final deceleration

This object contains the deceleration value used for decelerating from the maximum positioning velocity to the velocity V1 (object 2012_h, see section 4.2.12).

Object Description			
Index	Name	Object Type	Data Type
2013 _h	Profile D1	Variable	UNSIGNED32

Table 58: Object Description (2013_h)

Entry Description				
Sub-index	Access	PDO Mapping	Value Range	Default Value
0	rw	no	0... 16777215	0

Table 59: Entry Description (2013_h)

4.2.14 Object 2014_h: Profile stop Deceleration

This object sets the deceleration used to decelerate from the end velocity to zero velocity.

Object Description			
Index	Name	Object Type	Data Type
2014 _h	Profile stop deceleration	Variable	UNSIGNED32

Table 60: Object Description (2014_h)

Entry Description				
Sub-index	Access	PDO Mapping	Value Range	Default Value
0	rw	no	UNSIGNED32	0

Table 61: Entry Description (2014_h)

4.2.15 Object 2020_h: Closed-loop Mode

Setting this object to 1 selects closed-loop mode, setting it to 0 (default value) selects open-loop mode. Before activating closed-loop mode, all necessary parameters must have been set. After activating closed-loop mode, check object 2120_h until closed loop initialization has finished (please see also section 4.2.59).



Object Description			
Index	Name	Object Type	Data Type
2020 _h	Closed-loop mode	Variable	UNSIGNED8

Table 62: Object Description (2020_h)

Entry Description				
Sub-index	Access	PDO Mapping	Value Range	Default Value
0	rw	no	UNSIGNED8	0

Table 63: Entry Description (2020_h)

4.2.16 Object 2021_h: Correction Position P

Proportional controller P parameter for compensating a detected position deviation. Resulting P parameter is this parameter divided by 65536.

Object Description			
Index	Name	Object Type	Data Type
2021 _h	Correction position P	Variable	UNSIGNED32

Table 64: Object Description (2021_h)

Entry Description				
Sub-index	Access	PDO Mapping	Value Range	Default Value
0	rw	no	0... 16777215	0

Table 65: Entry Description (2021_h)

4.2.17 Object 2022_h: Maximum Correction Tolerance

This object defines the tolerance range for position deviation.

Object Description			
Index	Name	Object Type	Data Type
2022 _h	Maximum correction tolerance	Variable	UNSIGNED8

Table 66: Object Description (2022_h)

Entry Description				
Sub-index	Access	PDO Mapping	Value Range	Default Value
0	rw	no	0...255	0

Table 67: Entry Description (2022_h)

4.2.18 Object 2027_h: Closed-loop Beta

This object sets the maximum commutation angle that can be used to compensate for an evaluated position deviation.

Object Description			
Index	Name	Object Type	Data Type
2027 _h	Maximum correction tolerance	Variable	UNSIGNED16

Table 68: Object Description (2027_h)

Entry Description				
Sub-index	Access	PDO Mapping	Value Range	Default Value
0	rw	no	0...511	255

Table 69: Entry Description (2027_h)

4.2.19 Object 2028_h: Closed-loop Offset

Offset for closed loop operation. Automatically measured during closed loop initialization. Normally no need to change this value.

Object Description			
Index	Name	Object Type	Data Type
2028 _h	Closed-loop Offset	Variable	INTEGER32

Table 70: Object Description (2028_h)

Entry Description				
Sub-index	Access	PDO Mapping	Value Range	Default Value
0	rw	no	-2147483648...2147483647	—

Table 71: Entry Description (2028_h)



4.2.20 Object 2029_h: Current Scaler Minimum

Minimum current setting for current regulation in closed-loop operation.

Object Description			
Index	Name	Object Type	Data Type
2029 _h	Current scaler minimum	Variable	UNSIGNED8

Table 72: Object Description (2029_h)

Entry Description				
Sub-index	Access	PDO Mapping	Value Range	Default Value
0	rw	no	0...255	—

Table 73: Entry Description (2029_h)

4.2.21 Object 202A_h: Current Scaler Maximum

Maximum current setting for current regulation in closed-loop operation.

Object Description			
Index	Name	Object Type	Data Type
202A _h	Current scaler maximum	Variable	UNSIGNED8

Table 74: Object Description (202A_h)

Entry Description				
Sub-index	Access	PDO Mapping	Value Range	Default Value
0	rw	no	0...255	—

Table 75: Entry Description (202A_h)

4.2.22 Object 202B_h: Correction Velocity P

This object defines the P parameter of the PI regulator which controls the maximum velocity during closed-loop regulation.

Object Description			
Index	Name	Object Type	Data Type
202B _h	Correction velocity P	Variable	UNSIGNED32

Table 76: Object Description (202B_h)



Entry Description				
Sub-index	Access	PDO Mapping	Value Range	Default Value
0	rw	no	0...16777215	—

Table 77: Entry Description (202B_n)

4.2.23 Object 202C_n: Correction Velocity I

This object defines the I parameter of the PI regulator which controls the maximum velocity during closed-loop regulation.

Object Description			
Index	Name	Object Type	Data Type
202C _n	Correction velocity I	Variable	UNSIGNED32

Table 78: Object Description (202C_n)

Entry Description				
Sub-index	Access	PDO Mapping	Value Range	Default Value
0	rw	no	0...16777215	—

Table 79: Entry Description (202C_n)

4.2.24 Object 202D_n: Correction Velocity I Clipping

This object defines the clipping of the error sum of the integral part of the PI regulator which controls the maximum velocity during closed loop regulation.

Object Description			
Index	Name	Object Type	Data Type
202D _n	Correction velocity I clipping	Variable	UNSIGNED16

Table 80: Object Description (202D_n)

Entry Description				
Sub-index	Access	PDO Mapping	Value Range	Default Value
0	rw	no	0...32767	—

Table 81: Entry Description (202D_n)



4.2.25 Object 202E_h: Correction Velocity DV Clock

This object defines the clock divider for the D part calculation of the regulator that controls the velocity during closed-loop regulation.

Object Description			
Index	Name	Object Type	Data Type
202E _h	Correction velocity DV clock	Variable	UNSIGNED16

Table 82: Object Description (202E_h)

Entry Description				
Sub-index	Access	PDO Mapping	Value Range	Default Value
0	rw	no	0...32767	—

Table 83: Entry Description (202E_h)

4.2.26 Object 202F_h: Correction Velocity DV Clipping

The maximum velocity used for position correction in closed-loop mode will be limited to the value set by this object.

Object Description			
Index	Name	Object Type	Data Type
202F _h	Correction velocity DV clock	Variable	UNSIGNED32

Table 84: Object Description (202F_h)

Entry Description				
Sub-index	Access	PDO Mapping	Value Range	Default Value
0	rw	no	UNSIGNED32	2147483647

Table 85: Entry Description (202F_h)

4.2.27 Object 2030_h: Upscale Delay

Delay used when increasing the motor current during closed-loop operation.

Object Description			
Index	Name	Object Type	Data Type
2030 _h	Upscale delay	Variable	UNSIGNED32

Table 86: Object Description (2030_h)



Entry Description				
Sub-index	Access	PDO Mapping	Value Range	Default Value
0	rw	no	0...16777215	—

Table 87: Entry Description (2030_h)

4.2.28 Object 2031_h: Downscale Delay

Delay used when decreasing the motor current during closed-loop operation.

Object Description			
Index	Name	Object Type	Data Type
2031 _h	Downscale delay	Variable	UNSIGNED32

Table 88: Object Description (2031_h)

Entry Description				
Sub-index	Access	PDO Mapping	Value Range	Default Value
0	rw	no	0...16777215	—

Table 89: Entry Description (2031_h)

4.2.29 Object 2033_h: Actual Scaling Factor

The actual current scaling factor (output of the current scaler) can be read from this object.

Object Description			
Index	Name	Object Type	Data Type
2033 _h	Actual scaling factor	Variable	UNSIGNED8

Table 90: Object Description (2033_h)

Entry Description				
Sub-index	Access	PDO Mapping	Value Range	Default Value
0	ro	no	0...255	—

Table 91: Entry Description (2033_h)

4.2.30 Object 2034_h: Field Weakening Minimum Velocity

Minimum speed for field weakening operation. For higher velocities the influence of the back EMF may be compensated. At this velocity the compensation will start.



Object Description			
Index	Name	Object Type	Data Type
2034 _h	Filed weakening minimum velocity	Variable	UNSIGNED32

Table 92: Object Description (2034_h)

Entry Description				
Sub-index	Access	PDO Mapping	Value Range	Default Value
0	rw	no	0...16777215	—

Table 93: Entry Description (2034_h)

4.2.31 Object 2035_h: Field Weakening Maximum Velocity

Maximum speed for field weakening operation. For higher velocities the influence of the back EMF may be compensated. At the field weakening minimum velocity (section 4.2.30) plus this velocity the back EMF compensation will reach its maximum.

Object Description			
Index	Name	Object Type	Data Type
2035 _h	Field weakening maximum velocity	Variable	UNSIGNED32

Table 94: Object Description (2035_h)

Entry Description				
Sub-index	Access	PDO Mapping	Value Range	Default Value
0	rw	no	0...16777215	—

Table 95: Entry Description (2035_h)

4.2.32 Object 2036_h: Field Weakening

For higher velocities the influence of the back EMF may be compensated. This is the compensation factor that will be added scaled by the current velocity and the minimum and maximum field weakening velocity.

Object Description			
Index	Name	Object Type	Data Type
2036 _h	Field weakening	Variable	UNSIGNED8

Table 96: Object Description (2036_h)



Entry Description				
Sub-index	Access	PDO Mapping	Value Range	Default Value
0	rw	no	0...255	—

Table 97: Entry Description (2036_h)

4.2.33 Object 204E_h: Boost Current

This object defines the motor current that will be used during the acceleration phase and the deceleration phase in open-loop mode. A value of 255 means 100% of the maximum motor current of the drive. When this object is set to zero the run current (section 4.2.4) will also be used for the acceleration and deceleration phase.

Object Description			
Index	Name	Object Type	Data Type
204E _h	Field weakening	Variable	UNSIGNED8

Table 98: Object Description (204E_h)

Entry Description				
Sub-index	Access	PDO Mapping	Value Range	Default Value
0	rw	no	0...255	—

Table 99: Entry Description (204E_h)

4.2.34 Object 2089_h: Setting Delay

This object has to be used for setting a standstill period before the current is changed down to standby current.

Unit: 10msec

Object Description			
Index	Name	Object Type	Data Type
2089 _h	Setting Delay	Variable	UNSIGNED16

Table 100: Object Description (2089_h)

Entry Description				
Sub-index	Access	PDO Mapping	Value Range	Default Value
0	rw	no	0...65535	200

Table 101: Entry Description (2089_h)

4.2.35 Object 208C_h: Velocity Dimension Index

With this object different units can be chosen:

- Writing 0 selects internal units.
- Writing 181 sets PPS for velocity and PPS/s for acceleration.

This can only be changed in SWITCHED_ON_DISABLED mode.

Object Description			
Index	Name	Object Type	Data Type
208C _h	Velocity Dimension Index	Variable	UNSIGNED8

Table 102: Object Description (208C_h)

Entry Description				
Sub-index	Access	PDO Mapping	Value Range	Default Value
0	rw	no	0/181	181

Table 103: Entry Description (208C_h)

4.2.36 Object 208E_h: Acceleration Dimension Index

With this object, the unit for acceleration can be read out. The unit can be set using object 208Ch. Object 208E_h reads 0 when internal units are selected and 179 when PPS/s is selected.

Object Description			
Index	Name	Object Type	Data Type
208E _h	Acceleration Dimension Index	Variable	UNSIGNED8

Table 104: Object Description (208E_h)

Entry Description				
Sub-index	Access	PDO Mapping	Value Range	Default Value
0	ro	no	0/179	179

Table 105: Entry Description (208E_h)

4.2.37 Object 2092_h: Chopper Blank Time

This object serves for selecting the comparator blank time. This time needs to safely cover the switching event and the duration of the ringing on the sense resistor. For low current drivers, a setting of 1 or 2 is good. For higher current applications a setting of 2 or 3 will be required.



Object Description			
Index	Name	Object Type	Data Type
2092 _h	Chopper Blank Time	Variable	UNSIGNED8

Table 106: Object Description (2092_h)

Entry Description				
Sub-index	Access	PDO Mapping	Value Range	Default Value
0	rw	no	0...3	2

Table 107: Entry Description (2092_h)

4.2.38 Object 2093_h: Chopper Mode

Select the chopper mode using this object:

- 0 – spreadCycle chopper
- 1 – classic constant off time chopper

Object Description			
Index	Name	Object Type	Data Type
2093 _h	Chopper Mode	Variable	UNSIGNED8

Table 108: Object Description (2093_h)

Entry Description				
Sub-index	Access	PDO Mapping	Value Range	Default Value
0	rw	no	0/1	0

Table 109: Entry Description (2093_h)

4.2.39 Object 2094_h: Chopper Hysteresis Decrement

This object serves for the hysteresis decrement setting. This setting determines the slope of the hysteresis during on time and during fast decay time.

- 0 – fast decrement
- 3 – very slow decrement

Object Description			
Index	Name	Object Type	Data Type
2094 _h	Chopper Hysteresis Decrement	Variable	UNSIGNED8

Table 110: Object Description (2094_h)

Entry Description				
Sub-index	Access	PDO Mapping	Value Range	Default Value
0	rw	no	0...3	0

Table 111: Entry Description (2094_h)

4.2.40 Object 2095_h: Chopper Hysteresis End

This object provides the setting of the hysteresis end value after a number of decrements. The decrement interval time is controlled by object 2094_h (section 4.2.39).

Possible values are:

- -3...-1 – negative hysteresis end setting
- 0 – zero hysteresis end setting
- 1...12 – positive hysteresis end setting

Object Description			
Index	Name	Object Type	Data Type
2095 _h	Chopper Hysteresis End	Variable	SIGNED8

Table 112: Object Description (2095_h)

Entry Description				
Sub-index	Access	PDO Mapping	Value Range	Default Value
0	rw	no	-3...12	0

Table 113: Entry Description (2095_h)

4.2.41 Object 2096_h: Chopper Hysteresis Start

This object provides the hysteresis start setting. Please notice that this value is an offset to the hysteresis end value.

Object Description			
Index	Name	Object Type	Data Type
2096 _h	Chopper Hysteresis Start	Variable	UNSIGNED8

Table 114: Object Description (2096_h)



Entry Description				
Sub-index	Access	PDO Mapping	Value Range	Default Value
0	rw	no	0...8	3

Table 115: Entry Description (2096_h)

4.2.42 Object 2097_h: Chopper Off Time

The off time setting controls the minimum chopper frequency. Under normal circumstances, an off time within the range of 5 μ s to 20 μ s is used. Off time setting for constant t_{OFF} chopper: $N_{CLK} = 12 + 32 * t_{OFF}$. Minimum is 64 clocks.

Setting this parameter to zero completely disables all driver transistors and so lets the motor free-wheel.

Object Description			
Index	Name	Object Type	Data Type
2097 _h	Chopper Off Time	Variable	UNSIGNED8

Table 116: Object Description (2097_h)

Entry Description				
Sub-index	Access	PDO Mapping	Value Range	Default Value
0	rw	no	0 / 2...15	5

Table 117: Entry Description (2097_h)

4.2.43 Object 2098_h: Smart Energy Current Minimum

This object provides the setting of the lower motor current limit for coolStep operation by scaling the CS value.

Possible values are:

- 0 – 1/2 of maximum motor current setting (section 4.2.4)
- 1 – 1/4 of maximum motor current setting (section 4.2.4)

Object Description			
Index	Name	Object Type	Data Type
2098 _h	Smart Energy Current Minimum	Variable	UNSIGNED8

Table 118: Object Description (2098_h)

Entry Description				
Sub-index	Access	PDO Mapping	Value Range	Default Value
0	rw	no	0/1	0

Table 119: Entry Description (2098_h)

4.2.44 Object 2099_h: Smart Energy Current Down Step

This object provides the setting of the number of stallGuard2 readings above the upper threshold necessary for each current decrement of the motor current.

Possible values are:

- 0 – 32 measurements – slowest decrement
- 1 – 8 measurements
- 2 – 2 measurements
- 3 – 1 measurements – fastest decrement

Object Description			
Index	Name	Object Type	Data Type
2099 _h	Smart Energy Current Down Step	Variable	UNSIGNED8

Table 120: Object Description (2099_h)

Entry Description				
Sub-index	Access	PDO Mapping	Value Range	Default Value
0	rw	no	0...3	0

Table 121: Entry Description (2099_h)

4.2.45 Object 209A_h: Smart Energy Hysteresis

This object sets the distance between the lower and the upper threshold for stallGuard2 reading. Above the upper threshold the motor current becomes decreased.

Hysteresis: (smartEnergy hysteresis value + 1) * 32

Upper stallGuard threshold: (smartEnergy hysteresis start + smartEnergy hysteresis + 1) * 32

Object Description			
Index	Name	Object Type	Data Type
209A _h	Smart Energy Hysteresis	Variable	UNSIGNED8

Table 122: Object Description (209A_h)



Entry Description				
Sub-index	Access	PDO Mapping	Value Range	Default Value
0	rw	no	0...15	0

Table 123: Entry Description (209A_h)

4.2.46 Object 209B_h: Smart Energy Current Up Step

This object sets the current increment step. The current becomes incremented for each measured stallGuard2 value below the lower threshold (see smart energy hysteresis start (object 209C_h, section 4.2.47).

Possible values are:

- 0 – 1 step – slowest increment
- 1 – 2 steps
- 2 – 4 steps
- 3 – 8 steps – fastest increment

Object Description			
Index	Name	Object Type	Data Type
209B _h	Smart Energy Current Up Step	Variable	UNSIGNED8

Table 124: Object Description (209B_h)

Entry Description				
Sub-index	Access	PDO Mapping	Value Range	Default Value
0	rw	no	0...3	0

Table 125: Entry Description (209B_h)

4.2.47 Object 209C_h: Smart Energy Hysteresis Start

This object serves to set the lower threshold for the stallGuard2 value (see smart Energy current up step (section 4.2.46). Setting this to 0 disables the coolStep function.

Object Description			
Index	Name	Object Type	Data Type
209C _h	Smart Energy Hysteresis Start	Variable	UNSIGNED8

Table 126: Object Description (209C_h)

Entry Description				
Sub-index	Access	PDO Mapping	Value Range	Default Value
0	rw	no	0...15	0

Table 127: Entry Description (209C_h)

4.2.48 Object 209D_h: Smart Energy Filter Enable

This object is used to set the stallGuard2 filter for more precision of the measurement. It reduces the measurement frequency to one measurement per four fullsteps if set.

In most cases it is expedient to set the filtered mode when using coolStep. Use the standard mode for step loss detection.

Possible values are:

- 0 – standard mode
- 1 – filtered mode

Object Description			
Index	Name	Object Type	Data Type
209D _h	Smart Energy Filter Enable	Variable	UNSIGNED8

Table 128: Object Description (209D_h)

Entry Description				
Sub-index	Access	PDO Mapping	Value Range	Default Value
0	rw	no	0/1	0

Table 129: Entry Description (209D_h)

4.2.49 Object 209E_h: stallGuard2 Threshold

This signed value controls the stallGuard2 threshold level for stall output and sets the optimum measurement range for readout. A lower value gives a higher sensitivity. Zero is the starting value. A higher value makes stallGuard2 less sensitive and requires more torque to indicate a stall.

Object Description			
Index	Name	Object Type	Data Type
209E _h	stallGuard2 Threshold	Variable	SIGNED8

Table 130: Object Description (209E_h)

Entry Description				
Sub-index	Access	PDO Mapping	Value Range	Default Value
0	rw	no	-63...63	0

Table 131: Entry Description (209E_h)

4.2.50 Object 20A1_h: Short Protection Disable

This object is used to enable or to disable the short to ground protection. Normally there is no need to change this. Use the default value.

Possible values are:

- 0 – Short to GND protection enabled
- 1 – Short to GND protection disabled

Object Description			
Index	Name	Object Type	Data Type
20A1 _h	Short Protection Disable	Variable	UNSIGNED8

Table 132: Object Description (20A1_h)

Entry Description				
Sub-index	Access	PDO Mapping	Value Range	Default Value
0	rw	no	0/1	0

Table 133: Entry Description (20A1_h)

4.2.51 Object 20A3_h: Vsense

This object is used for setting the sense resistor voltage based current scaling. *Use the default value and change only when recommended by Trinamic.*

Possible settings are:

- 0 - Full scale sense resistor voltage is 1/18 VDD
- 1 - Full scale sense resistor voltage is 1/36 VDD

Object Description			
Index	Name	Object Type	Data Type
20A3 _h	Vsense	Variable	UNSIGNED8

Table 134: Object Description (20A3_h)

Entry Description				
Sub-index	Access	PDO Mapping	Value Range	Default Value
0	rw	no	0/1	0

Table 135: Entry Description (20A3_h)

4.2.52 Object 20A4_h: Stop on Stall

Below this speed the motor will not be stopped. Above this speed the motor will be stopped in case the stallGuard2 load value reaches zero.

Object Description			
Index	Name	Object Type	Data Type
20A4 _h	Stop on Stall	Variable	UNSIGNED32

Table 136: Object Description (20A4_h)

Entry Description				
Sub-index	Access	PDO Mapping	Value Range	Default Value
0	rw	no	0...2147483647	0

Table 137: Entry Description (20A4_h)

4.2.53 Object 20A5_h: Smart Energy Threshold Speed

The coolStep functionality will be enabled when the actual speed is above this speed. It will be disabled again when the actual speed drops below this value.

Object Description			
Index	Name	Object Type	Data Type
20A5 _h	Smart Energy Threshold Speed	Variable	UNSIGNED32

Table 138: Object Description (20A5_h)

Entry Description				
Sub-index	Access	PDO Mapping	Value Range	Default Value
0	rw	no	0...2147483647	0

Table 139: Entry Description (20A5_h)



4.2.54 Object 2100_h: Home Offset Display

This object shows the home offset. The value is given in microsteps.

Object Description			
Index	Name	Object Type	Data Type
2100 _h	Home Offset Display	Variable	SIGNED32

Table 140: Object Description (2100_h)

Entry Description				
Sub-index	Access	PDO Mapping	Value Range	Default Value
0	ro	no	-2147483648...2147483647	0

Table 141: Entry Description (2100_h)

4.2.55 Object 2101_h: Actual Load Value

This object shows the home offset. The value is given in microsteps.

Object Description			
Index	Name	Object Type	Data Type
2101 _h	Home Offset Display	Variable	UNSIGNED16

Table 142: Object Description (2101_h)

Entry Description				
Sub-index	Access	PDO Mapping	Value Range	Default Value
0	ro	no	0...1023	0

Table 143: Entry Description (2101_h)

4.2.56 Object 2102_h: Driver Error Flags

This object shows the error flags of the motor driver IC.



Error Flags		
Bit	Name	Meaning
7	OT	Overtemperature
6	OTPW	Temperature pre-warning
5	UV	Undervoltage
4	OCHS	Overcurrent high side
3	OLB	Open load on bridge B
2	OLA	Open load on bridge A
1	OCB	Overcurrent on bridge B
0	OCA	Overcurrent on bridge A

Table 144: Driver Error Flags (2102_h)

Object Description			
Index	Name	Object Type	Data Type
2102 _h	Home Offset Display	Variable	UNSIGNED8

Table 145: Object Description (2102_h)

Entry Description				
Sub-index	Access	PDO Mapping	Value Range	Default Value
0	ro	no	0...255	0

Table 146: Entry Description (2102_h)

4.2.57 Object 2107_h: Microstep resolution display

This object shows the microstep resolution, set by object 2000_h (please see section 4.2.1).

Object Description			
Index	Name	Object Type	Data Type
2107 _h	Microstep resolution display	Variable	UNSIGNED8

Table 147: Object Description (2107_h)



Entry Description				
Sub-index	Access	PDO Mapping	Value Range	Default Value
0	ro	no	0...8	8

Table 148: Entry Description (2107_h)

4.2.58 Object 210B_h: Step Counter

This object shows the overall number of microsteps done by this motor so far. The value can be read as a 64 bit value (sub-index 3) or split into two 32 bit values (sub-index 1 and sub-index 2).

Object Description			
Index	Name	Object Type	Data Type
210B _h	Step Counter	Variable	RECORD

Table 149: Object Description (210B_h)

Entry Description					
Sub-index	Description	Access	PDO Mapping	Value Range	Default Value
1	Lower 32 Bits	ro	no	0... ffffffff _h	0
2	Higher 32 Bits	ro	no	0... ffffffff _h	0
3	64 Bit Value	ro	no	0... ffffffffffffffff _h	0

Table 150: Entry Description (210B_h)

4.2.59 Object 2120_h: Closed-loop Initialization Flag

The closed-loop initialization flag reads 1 when closed-loop is active and the initialization of closed-loop has finished. Otherwise this object reads 0.

Object Description			
Index	Name	Object Type	Data Type
2120 _h	Closed Loop Initialization Flag	Variable	UNSIGNED8

Table 151: Object Description (2120_h)

Entry Description				
Sub-index	Access	PDO Mapping	Value Range	Default Value
0	ro	no	0/1	—

Table 152: Entry Description (2120_h)



4.2.60 Object 2700_h: TMCL Direct Communication

After writing the make signature 656b616d_h to this object the drive switches to TMCL mode. The drive can then only be controlled via TMCL commands written to the OS command object 1023/01_h. The drive can only be reset to normal CANopen functionality using the DS-301 reset application command.

Object Description			
Index	Name	Object Type	Data Type
2700 _h	TMCL Direct Communication	Variable	UNSIGNED32

Table 153: Object Description (2700_h)

Entry Description				
Sub-index	Access	PDO Mapping	Value Range	Default Value
0	rw	no	656b616d _h	0

Table 154: Entry Description (2700_h)

4.2.61 Object 2701_h: Manufacturer Specific Mode

Writing the make signature to this object turns on the manufacturer specific mode. The manufacturer specific mode can be turned off again by writing the kill signature to this object. The manufacturer specific mode has the following features:

- PDOs do not need to be disabled and re-enabled when the PDO mapping is to be changed.
- The RTR bit in the COB-ID of PDO definitions is ignored.

read:	0	=	manufacturer specific mode is inactive
	1	=	manufacturer specific mode is active
write:	656b616d _h	=	make signature
	6c6c696b _h	=	kill signature

Object Description			
Index	Name	Object Type	Data Type
2701 _h	Manufacturer Specific Mode	Variable	UNSIGNED32

Table 155: Object Description (2701_h)

Entry Description				
Sub-index	Access	PDO Mapping	Value Range	Default Value
0	rw	no	see above	0

Table 156: Entry Description (2701_h)



4.2.62 Object 2702_h: Device Digital Inputs

Bits 19...16 of this object reflect the states of the four general purpose inputs of the module.

Bit Definitions	
Bit	Description
16	IN0
17	IN1
18	IN2
19	IN3

Table 157: Bit Definitions (2702_h)

Object Description			
Index	Name	Object Type	Data Type
2702 _h	Device Digital Inputs	Variable	UNSIGNED32

Table 158: Object Description (2702_h)

Entry Description				
Sub-index	Access	PDO Mapping	Value Range	Default Value
0	ro	no	-	0

Table 159: Entry Description (2702_h)

4.2.63 Object 2703_h: Device Digital Outputs

With this object the digital outputs (general purpose outputs) can be set. Bits 19...16 of sub index 1 switch outputs OUT0, OUT1, OUT2 and OUT3 of the module. Bits 19...16 of sub index 2 determine which outputs can be switched. The number of available digital outputs depends on the module type.

Bit Definitions	
Bit	Description
16	OUT0
17	OUT1
18	OUT2
19	OUT3

Table 160: Bit Definitions (2703_h)



Object Description			
Index	Name	Object Type	Data Type
2703 _h	Smart Energy Current Up Step	Variable	ARRAY

Table 161: Object Description (2703_h)

Entry Description					
Sub-index	Description	Access	PDO Mapping	Value Range	Default Value
1	Physical outputs	rw	no	UNSIGNED32	0
2	Output mask	rw	no	UNSIGNED32	0

Table 162: Entry Description (2703_h)

4.2.64 Object 2704_h: CAN Bit Rate

With this object it is possible to change the CAN bit rate. To do this, first write the new value to this object. Then, store the new setting by writing the save signature to object 2706_h. After that, reset the module. The new setting then becomes active.

Object Description			
Index	Name	Object Type	Data Type
2704 _h	CAN Bit Rate	Variable	UNSIGNED16

Table 163: Object Description (2704_h)

Entry Description				
Sub-index	Access	PDO Mapping	Value Range	Default Value
0	rw	no	20,50,100,125,250,500,800,1000	1000

Table 164: Entry Description (2704_h)

How to change the bit rate of a module:

- Write new bit rate in object 2704_h.
- Write the save signature 65766173_h to sub-index 1 of object 2706_h.
- Reset module.

4.2.65 Object 2705_h: Node ID

On modules that do not have address switches the node ID can be selected using this object. On modules with address switches the node ID is normally selected using the address switches. Only when the address switches are set to an invalid value (0 or >127) this object overrides the address switch setting.



To change the node ID, first write the new node ID to this object. Then, store the new setting by writing the save signature to object 2706_h. After that, reset the module. The new setting then becomes active.

Object Description			
Index	Name	Object Type	Data Type
2705 _h	Node ID	Variable	UNSIGNED8

Table 165: Object Description (2705_h)

Entry Description				
Sub-index	Access	PDO Mapping	Value Range	Default Value
0	rw	no	1...127	1

Table 166: Entry Description (2705)_h

How to change the node ID of a module:

- Write new node ID to object 2705_h.
- Write save signature 65766173_h to sub-index 1 of object 2706_h.
- Reset the module.

4.2.66 Object 2706_h: Store

Writing the save signature to this object permanently saves changes made to objects 2704_h and 2705_h. The save signature is 65766173_h.

Object Description			
Index	Name	Object Type	Data Type
2706 _h	Store	Variable	UNSIGNED32

Table 167: Object Description (2706_h)

Entry Description				
Sub-index	Access	PDO Mapping	Value Range	Default Value
0	rw	no	save signature: 65766173 _h	1

Table 168: Entry Description (2706)_h

4.2.67 Object 2707_h: CAN Bit Rate Load

This object shows the selected CAN bit rate.



Object Description			
Index	Name	Object Type	Data Type
2707 _h	CAN Bit Rate Load	Variable	UNSIGNED8

Table 169: Object Description (2707_h)

Entry Description				
Sub-index	Access	PDO Mapping	Value Range	Default Value
0	ro	no	20...1000	depends on bit rate

Table 170: Entry Description (2707_h)

4.2.68 Object 2708_h: Node ID Load

This object shows the selected node ID.

Object Description			
Index	Name	Object Type	Data Type
2708 _h	Node ID Load	Variable	UNSIGNED8

Table 171: Object Description (2708_h)

Entry Description				
Sub-index	Access	PDO Mapping	Value Range	Default Value
0	ro	no	1..127	Depends on node ID setting

Table 172: Entry Description (2708_h)

4.2.69 Object 270E_h: Device Analog Inputs

This object shows the values of the analog inputs of the device.

Object Description			
Index	Name	Object Type	Data Type
270E _h	Device Analog Inputs	Array	UNSIGNED32

Table 173: Object Description (270E_h)



Entry Description					
Sub-index	Description	Access	PDO Mapping	Value Range	Default Value
1	Analog input 0	ro	no	0...4095	–
2	Analog input 1	ro	no	0...4095	–
3	Analog input 2	ro	no	0...4095	–
4	Analog input 3	ro	no	0...4095	–

Table 174: Entry Description (270E_h)



5 Profile specific area

The profile segment contains CiA-402 standard motion control objects. These objects control the motion control functions of the TMCM-3315. Since it is not possible to operate the modes in parallel, the user is able to activate the required function by selecting a mode of operation. The control device writes to the modes of operation object in order to select the operation mode. The drive device provides the modes of operation display object to indicate the actual activated operation mode. Controlword, statusword, and set-points are used mode-specific. This implies the responsibility of the control device to avoid inconsistencies and erroneous behavior.

The following operating modes (selectable via object 6060_h, please see 5.1.6) are implemented on the TMCM-3315:

- Profile position mode (pp)
- Profile velocity mode (pv)
- Homing mode (hm)
- Cyclic position mode (csp)

i Info

This section of the manual only shows the object indices for motor #0. Of course the same objects are also available for the other motors. For the other motors, add an offset of $motor_number \cdot 800_h$ to the object index. So for example the control word (object 6040_h for motor #0) can be accessed as object 6840_h for motor #1 and as object 7040_h for motor #2. Please see also section 2.4.1.

Multi-axis Object Indices	
Motor	Object Index Range
Motor #0	6000 _h – 67FF _h
Motor #1	6800 _h – 6FFF _h
Motor #2	7000 _h – 77FF _h

Table 175: Multi-axis Object Indices (Profile specific Area)

5.1 Detailed object specifications

5.1.1 Object 605A_h: Quick stop option code

This object indicates what action is performed when the quick stop function is executed. The slow down ramp is the deceleration value of the used mode of operation. The following quick stop option codes are supported in the current version of the CANopen firmware:



Value Definition	
Value	Definition
1	Slow down on <i>slow down ramp</i> and transit into <i>switch on disabled</i>
2	Slow down on <i>quick stop ramp</i> and transit into <i>switch on disabled</i>
5	Slow down on <i>slow down ramp</i> and stay in <i>quick stop active</i>
6	Slow down on <i>quick stop ramp ramp</i> and stay in <i>quick stop active</i>

Table 176: Value Description (605A_h)

Object Description			
Index	Name	Object Type	Data Type
605A _h	Quick stop option code	Variable	SIGNED16

Table 177: Object Description (605A_h)

Entry Description				
Sub-index	Access	PDO Mapping	Value Range	Default Value
0	rw	no	1/2/5/6	2

Table 178: Entry Description (605A_h)

5.1.2 Object 605B_h: Shutdown option code

This object indicates what action is performed if there is a transition from *operation enabled* state to *ready to switch on state*. The shutdown option code always has the value 0 as only this is supported.

Value Definition	
Value	Definition
0	Disable drive function (switch off the power stage)

Table 179: Value Description (605B_h)

Object Description			
Index	Name	Object Type	Data Type
605B _h	Quick stop option code	Variable	UNSIGNED16

Table 180: Object Description (605B_h)



Entry Description				
Sub-index	Access	PDO Mapping	Value Range	Default Value
0	rw	no	0	0

Table 181: Entry Description (605B_h)

5.1.3 Object 605C_h: Disable operation option code

This object indicates what action is performed if there is a transition from *operation enabled* state to *switched on* state. The disable operation option code always has the value 1 as only this is supported. The slow down ramp is the deceleration value of the used mode of operation.

Value Definition	
Value	Definition
1	Slow down on slow down ramp

Table 182: Value Description (605C_h)

Object Description			
Index	Name	Object Type	Data Type
605C _h	Disable operation option code	Variable	UNSIGNED16

Table 183: Object Description (605C_h)

Entry Description				
Sub-index	Access	PDO Mapping	Value Range	Default Value
0	rw	no	1	1

Table 184: Entry Description (605C_h)

5.1.4 Object 605D_h: Halt option code

This object indicates what action is performed when the halt function is executed. The slow down ramp is the deceleration value of the used mode of operation. The halt option code always has the value 1 as only this is supported.

Value Definition	
Value	Definition
1	Slow down on slow down ramp and stay in <i>operation enabled</i>

Table 185: Value Description (605D_h)

Object Description			
Index	Name	Object Type	Data Type
605D _h	Halt option code	Variable	UNSIGNED16

Table 186: Object Description (605D_h)

Entry Description				
Sub-index	Access	PDO Mapping	Value Range	Default Value
0	rw	no	1	1

Table 187: Entry Description (605D_h)

5.1.5 Object 605E_h: Fault reaction option code

This object indicates what action is performed when fault is detected in the power drive system. The slow down ramp is the deceleration value of the used mode of operation. The fault reaction option code always has the value 2 as only this is supported.

Value Definition	
Value	Definition
2	Slow down on quick stop ramp

Table 188: Value Description (605E_h)

Object Description			
Index	Name	Object Type	Data Type
605E _h	Fault reaction option code	Variable	UNSIGNED16

Table 189: Object Description (605E_h)

Entry Description				
Sub-index	Access	PDO Mapping	Value Range	Default Value
0	rw	no	2	2

Table 190: Entry Description (605E_h)

5.1.6 Object 6060_h: Modes of operation

This object indicates the requested operation mode. Supported operating modes are:



Value Definition	
Value	Mode
0	No mode
1	Profile position mode (pp)
3	Profile velocity mode (pv)
6	Homing mode (hm)

Table 191: Value Description (6060_h)

The motor will not run when the operating mode is set to 0. It will be stopped when the motor is running in one of the supported operating modes and the operating mode is then switched to 0.

Object Description			
Index	Name	Object Type	Data Type
6060 _h	Modes of operation	Variable	SIGNED8

Table 192: Object Description (6060_h)

Entry Description				
Sub-index	Access	PDO Mapping	Value Range	Default Value
0	rw	refer to CiA-402	0/1/3/6	0

Table 193: Entry Description (6060_h)

5.1.7 Object 6061_h: Modes of operation

This object shows the operating mode that is currently set.

Value Definition	
Value	Mode
0	No mode
1	Profile position mode (pp)
3	Profile velocity mode (pv)
6	Homing mode (hm)

Table 194: Value Description (6061_h)

The motor will not run when the operating mode is set to 0. It will be stopped when the motor is running in one of the supported operating modes and the operating mode is then switched to 0.



Object Description			
Index	Name	Object Type	Data Type
6061 _h	Modes of operation display	Variable	SIGNED8

Table 195: Object Description (6061_h)

Entry Description				
Sub-index	Access	PDO Mapping	Value Range	Default Value
0	rw	refer to CiA-402	0/1/3/6	0

Table 196: Entry Description (6061_h)

5.1.8 Object 606A_h: Sensor selection code

This object provides the source of the velocity sensor actual value. It selects whether an encoder is to be used or not.

Value Definition	
Value	Mode
0	Encoder used
-1	No encoder

Table 197: Value Description (606A_h)

Object Description			
Index	Name	Object Type	Data Type
606A _h	Sensor selection code	Variable	SIGNED16

Table 198: Object Description (606A_h)

Entry Description				
Sub-index	Access	PDO Mapping	Value Range	Default Value
0	rw	no	0/-1	-1

Table 199: Entry Description (606A_h)

5.1.9 Object 608F_h: Position Encoder Resolution

This object defines the resolution of the encoder. The position encoder resolution is calculated by the following formula:

$$position\ encoder\ resolution = \frac{encoder\ increments}{motor\ revolutions}$$



All values are dimensionless.

Object Description			
Index	Name	Object Type	Data Type
608F _h	Position Encoder Resolution	Array	UNSIGNED32

Table 200: Object Description (608F_h)

Entry Description					
Sub-index	Description	Access	PDO Mapping	Value Range	Default Value
0	Highest sub-index supported	ro	no	2	2
1	Encoder increments	rw	no	0...2147483647	1
2	Motor revolutions	ro	no	1	1

Table 201: Entry Description (608F_h)

5.1.10 Object 60FD_h: Digital Inputs

This object contains the states of the digital inputs of the module. Starting from bit 0, every bit reflects the state of one digital input. The number of valid bits depends on the number of digital inputs on the module used.

Object Description			
Index	Name	Object Type	Data Type
60FD _h	Digital inputs	Variable	UNSIGNED32

Table 202: Object Description (60FD_h)

Entry Description				
Sub-index	Access	PDO Mapping	Value Range	Default Value
0	rw	mappable	UNSIGNED32	0

Table 203: Entry Description (60FD_h)

5.1.11 Object 6502_h: Supported Drive Modes

This object provides information on the supported drive modes. A bit that is set means that the mode is supported, a bit that is not set means that the mode is not supported by the drive.



Value Definition	
Bit	Mode
0	Profile position mode (pp)
1	Velocity mode (vl)
2	Profile velocity mode (pv)
3	Torque mode (tq)
4	Reserved
5	Homing mode (hm)
6	Interpolated position mode (ip)
7	Cyclic synchronous position mode (csp)
8	Cyclic synchronous velocity mode (csv)
9	Cyclic synchronous torque mode (cst)

Table 204: Value Definition (6502_h)

Object Description			
Index	Name	Object Type	Data Type
6502 _h	Supported drive modes	Variable	UNSIGNED32

Table 205: Object Description (6502_h)

Entry Description				
Sub-index	Access	PDO Mapping	Value Range	Default Value
0	ro	no	UNSIGNED32	Depends on supported modes.

Table 206: Entry Description (6502_h)

6 Profile position mode

A target position is applied to the trajectory generator. It is generating a position demand value for the position control loop described in the position control function.

Please refer to object 6060_h (section 5.1.6) for information about how to choose an operation mode.

Object 6061_h (section 5.1.7) shows the operation mode that is set.

6.1 Detailed Object Specifications

The following text offers detailed object specifications. For a better understanding, it is necessary to see how the state machine works.

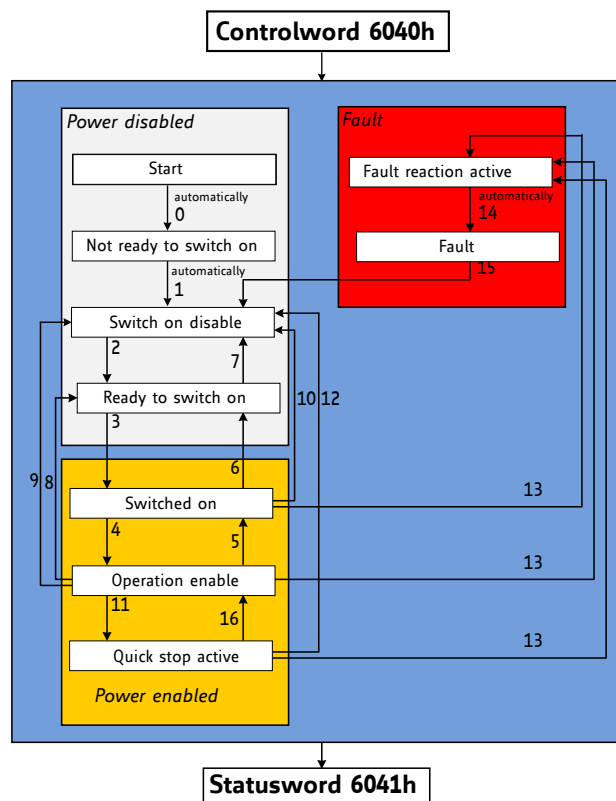

Figure 12: DS402 Finite State Machine

Notes on state transitions:

- Commands directing a change in state are processed completely and the new state achieved before additional state change commands are processed.
- Transitions 0 and 1 occur automatically at drive power-on or reset. Transition 14 occurs automatically, too. All other state changes must be directed by the host.
- Drive function disabled indicates that no current is being supplied to the motor.
- Drive function enabled indicates that current is available for the motor and profile position and profile velocity reference values may be processed.



6.1.1 Object 6040_n: Control Word

This object indicates the received command controlling the power drive system finite state automaton (PDS FSA). The CiA-402 state machine can be controlled using this object. Please refer to figure 12 for detailed information.

Structure of the control word											
15	11	10	9	8	7	6	4	3	2	1	0
nu	r	oms	h	fr	oms	eo	qs	ev	so		
MSB										LSB	

Legend: nu=not used; r=reserved; oms=operation mode specific; h=halt; fr=fault reset; eo=enable operation; qs=quick stop; ev=enable voltage; so=switch on.

Table 207: Structure of the Control Word in pp Mode

Operation mode specific bits in pp mode		
Bit	Name	Definition
4	New set point	0-to-1: the next positioning will be started.
5	Change immediately	Not supported.
6	Absolute / relative	0: New position is absolute. 1: New position is relative.
9	Change set point	Not supported.

Table 208: Operation Mode specific Bits in pp Mode

Command coding						
Command	Bits of control word					Transitions
	Bit 7	Bit 3	Bit 2	Bit 1	Bit 0	
Shutdown	0	x	1	1	0	2,6,8
Switch on	0	0	1	1	1	3
Switch on & enable operation	0	1	1	1	1	3, 4
Disable voltage	0	x	x	0	x	7,9,10,12
Quick stop	0	x	0	1	x	7,10,11
Disable operation	0	0	1	1	1	5
Enable operation	0	1	1	1	1	4, 16
Fault reset	0-to-1	x	x	x	x	15

Table 209: Command Coding



Object Description			
Index	Name	Object Type	Data Type
6040 _h	Controlword	Variable	UNSIGNED16

Table 210: Object Description (6040_h in pp Mode)

Entry Description				
Sub-index	Access	PDO Mapping	Value Range	Default Value
0	rw	see CiA402-3	See command coding above.	

Table 211: Entry Description (6040_h in pp Mode)

6.1.2 Object 6041_h: Status Word

This object provides the status of the PDS FSA. It reflects the status of the CiA-402 state machine. Please refer to figure 12 for detailed information. The object is structured as defined below. For more information about the coding please refer to the CANopen Drives and motion control device profile, part 2.

Structure of the Status Word															
15	14	13	12	11	10	9	8	7	6	5	4	3	2	1	0
dir	mot	oms	ila	tr	rm	ms	w	sod	qs	ve	f	oe	so	rtso	
MSB														LSB	

Legend: nu=not used; r=reserved; oms=operation mode specific; h=halt; fr=fault reset; eo=enable operation; qs=quick stop; ev=enable voltage; so=switch on.

Table 212: Structure of the Status Word in pp Mode

Trinamic Specific Bits		
Bit	Name	Definition
14	Motor activity	0: Motor stands still. 1: Motor rotates.
15	Direction of rotation	This bit shows the direction of rotation.

Table 213: Trinamic Specific Bits



Operation Mode specific Bits in pp Mode		
Bit	Name	Definition
10	Target reached	Set when the motor is within the position window.
12	Set point acknowledged	0: Set point processed. 1: Set point still in process.
13	Following error	Not supported.

Table 214: Operation Mode specific Bits in pp Mode

State Coding	
Status word	FSA state
xxxx xxxx x0xx 0000 _h	Not ready to switch on
xxxx xxxx x1xx 0000 _h	Switch on disabled
xxxx xxxx x01x 0001 _h	Ready to switch on
xxxx xxxx x01x 0011 _h	Switched on
xxxx xxxx x01x 0111 _h	Operation enabled
xxxx xxxx x00x 0111 _h	Quick stop active
xxxx xxxx x0xx 1111 _h	Fault reaction active
xxxx xxxx x0xx 1000 _h	Fault

Table 215: State Coding

Object Description			
Index	Name	Object Type	Data Type
6041 _h	Controlword	Variable	UNSIGNED16

Table 216: Object Description (6041_h in pp Mode)

Entry Description				
Sub-index	Access	PDO Mapping	Value Range	Default Value
0	rw	see CiA402-3	See state coding above.	

Table 217: Entry Description (6041_h in pp Mode)

6.1.3 Object 6062_h: Position Demand Value

This object provides the demanded position value. The value is given in microsteps. Object 6062_h indicates the actual position that the motor should have. It is not to be confused with objects 6063_h and 6064_h.



Object Description			
Index	Name	Object Type	Data Type
6062 _h	Position Demand Value	Variable	SIGNED32

Table 218: Object Description (6062_h)

Entry Description				
Sub-index	Access	PDO Mapping	Value Range	Default Value
0	ro	Refer to CiA402-3	SIGNED32	no

Table 219: Entry Description (6062_h)

6.1.4 Object 6063_h: Position Actual Internal Value

This object provides the actual value of the encoder or the motor. Please use the sensor selection object 606A_h (see section 5.1.8) for selecting the motor or the encoder first. Object 6063_h indicates the actual position of the encoder or the motor, re-scaled to the microstep resolution. The value is given in microsteps.

Object Description			
Index	Name	Object Type	Data Type
6063 _h	Position Actual Internal Value	Variable	SIGNED32

Table 220: Object Description (6063_h)

Entry Description				
Sub-index	Access	PDO Mapping	Value Range	Default Value
0	ro	Refer to CiA402-3	SIGNED32	no

Table 221: Entry Description (6063_h)

6.1.5 Object 6064_h: Position Actual Internal Value

This object provides the actual value of the position measurement device. It always contains the same value as object 6063_h.

Object Description			
Index	Name	Object Type	Data Type
6064 _h	Position Actual Internal Value	Variable	SIGNED32

Table 222: Object Description (6064_h)

Entry Description				
Sub-index	Access	PDO Mapping	Value Range	Default Value
0	ro	Refer to CiA402-3	SIGNED32	no

Table 223: Entry Description (6064_h)

6.1.6 Object 6065_h: Following Error Window

This object indicates the configured range of tolerated position values symmetrically to the position demand value. If the position actual value is out of the following error window, a following error occurs. A following error may occur when a drive is blocked, unreachable profile velocity occurs, or at wrong closed-loop coefficients. The value shall be given in microsteps.

When the difference between motor position (object 6062_h) and encoder position (object 6063_h or 6064_h) is greater than the value set here, the motor will be stopped and an emergency message will be sent. Setting this object to zero will turn off this feature completely.

Note Setting this object to a too low value will lead to false alarms.

Object Description			
Index	Name	Object Type	Data Type
6065 _h	Following Error Window	Variable	UNSIGNED32

Table 224: Object Description (6065_h)

Entry Description				
Sub-index	Access	PDO Mapping	Value Range	Default Value
0	rw	no	0...2147483647	0

Table 225: Entry Description (6065_h)

6.1.7 Object 6067_h: Position Window

This object indicates the configured symmetrical range of accepted positions relative to the target position. If the actual value of the position encoder is within the position window, this target position is regarded as having been reached. The value is given in increments. If the value of the position window is FFFFFFFF_h, the position window control is switched off. If this object is set to zero, the target reached event will be signaled when the demand position (6062_h) has reached the target position (6064_h). When the position window is set to a value greater than zero, the target reached event will be signaled when the actual encoder position value (6064_h) is within $(target_position - position_window)$ and $(target_position + position_window)$.



Object Description			
Index	Name	Object Type	Data Type
6067 _h	Position Window	Variable	UNSIGNED32

Table 226: Object Description (6067_h)

Entry Description				
Sub-index	Access	PDO Mapping	Value Range	Default Value
0	rw	no	UNSIGNED32	FFFFFFF _h

Table 227: Entry Description (6067_h)

6.1.8 Object 6068_h: Position Window Time

This object indicates the configured time, during which the actual position within the position window is measured. The value is given in ms. If this object is set to a value greater than zero and also the position window (6067_h) is set to a value greater than zero the target reached event will not be signaled until the actual position (6064_h) is at least as many milliseconds within the position window as defined by this object.

Object Description			
Index	Name	Object Type	Data Type
6068 _h	Position Window Time	Variable	UNSIGNED16

Table 228: Object Description (6068_h)

Entry Description				
Sub-index	Access	PDO Mapping	Value Range	Default Value
0	rw	no	UNSIGNED16	0

Table 229: Entry Description (6068_h)

6.1.9 Object 606C_h: Velocity Actual Value

This object shows the actual velocity value of the motor. The value is given in internal or user-defined velocity units (depending on object 208C_h, described in section 4.2.35).

Object Description			
Index	Name	Object Type	Data Type
606C _h	Velocity Actual Value	Variable	SIGNED32

Table 230: Object Description (606C_h)

Entry Description				
Sub-index	Access	PDO Mapping	Value Range	Default Value
0	ro	Refer to CiA402-3	SIGNED32	no

Table 231: Entry Description (606C_h)

6.1.10 Object 607A_h: Target Position

The target position is the position that the drive should move to in profile position mode using the current settings of motion control parameters (such as velocity, acceleration, deceleration, motion profile type etc.). The value of this object is interpreted as absolute or relative depending on the abs/rel flag in the controlword. It is given in microsteps.

Object Description			
Index	Name	Object Type	Data Type
607A _h	Target Position	Variable	SIGNED32

Table 232: Object Description (607A_h in pp Mode)

Entry Description				
Sub-index	Access	PDO Mapping	Value Range	Default Value
0	rw	Refer to CiA402-3	SIGNED32	0

Table 233: Entry Description (607A_h in pp Mode)

6.1.11 Object 607D_h: Software Position Limit

This object indicates the configured maximal and minimal software position limits. These parameters define the absolute position limits for the position demand value and the position actual value. Every new target position is checked against these limits. The limit positions are always relative to the machine home position. Before being compared with the target position, they are corrected internally by the home offset as follows:

$$\text{Corrected_min_position_limit} = \text{min_position_limit} - \text{home_offset}$$

$$\text{Corrected_max_position_limit} = \text{max_position_limit} - \text{home_offset}$$

Object Description			
Index	Name	Object Type	Data Type
607D _h	Software Position Limit	Array	SIGNED32

Table 234: Object Description (607D_h)

Entry Description					
Sub-index	Description	Access	PDO Mapping	Value Range	Default Value
1	Minimum Position Limit	rw	no	SIGNED32	-2147483648
2	Maximum Position Limit	rw	no	SIGNED32	2147483647

Table 235: Entry Description (607D_h)

6.1.12 Object 6081_h: Profile Velocity

This object indicates the configured velocity normally attained at the end of the acceleration ramp during a profiled motion and is valid for both directions of motion. The profile velocity is the maximum velocity used when driving to a new position. It is given in internal or user specific units (depending on object 208C_h, section 4.2.35).

Object Description			
Index	Name	Object Type	Data Type
6081 _h	Profile Velocity	Variable	SIGNED32

Table 236: Object Description (6081_h)

Entry Description				
Sub-index	Access	PDO Mapping	Value Range	Default Value
0	rw	no	SIGNED32	0

Table 237: Entry Description (6081_h)

6.1.13 Object 6082_h: End Velocity

This object indicates the configured velocity normally attained at the end of the deceleration ramp during a profiled motion and is valid for both directions of motion. The end velocity is the velocity used when reaching the new position. It is given in internal or user specific units (depending on object 208C_h, section 4.2.35).

Object Description			
Index	Name	Object Type	Data Type
6082 _h	End Velocity	Variable	SIGNED32

Table 238: Object Description (6082_h)

Entry Description				
Sub-index	Access	PDO Mapping	Value Range	Default Value
0	rw	no	SIGNED32	0

Table 239: Entry Description (6082_h)

6.1.14 Object 6083_h: Profile Acceleration

This object indicates the configured acceleration. Object 6083_h sets the maximum acceleration to be used in profile positioning and in profile velocity mode.

The units for object 6083_h can be chosen with object 208E_h, described in section 4.2.36.

Object Description			
Index	Name	Object Type	Data Type
6083 _h	Profile Acceleration	Variable	SIGNED32

Table 240: Object Description (6083_h)

Entry Description				
Sub-index	Access	PDO Mapping	Value Range	Default Value
0	rw	no	SIGNED32	0

Table 241: Entry Description (6083_h)

6.1.15 Object 6084_h: Profile Deceleration

This object indicates the configured deceleration. Object 6084_h sets the maximum deceleration to be used in profile positioning mode and in profile velocity mode.

The units for object 6084_h can be chosen with object 208E_h, described in section 4.2.36.

Object Description			
Index	Name	Object Type	Data Type
6084 _h	Profile Deceleration	Variable	SIGNED32

Table 242: Object Description (6084_h)

Entry Description				
Sub-index	Access	PDO Mapping	Value Range	Default Value
0	rw	no	SIGNED32	0

Table 243: Entry Description (6084_h)

6.1.16 Object 6085_h: Quick Stop Deceleration

This object indicates the configured deceleration used to stop the motor when the quick stop function is activated and the quick stop code object 605A_h is set to 2 (or 6). The value is given in the same unit as profile acceleration object 6083_h.



Object Description			
Index	Name	Object Type	Data Type
6085 _h	Quick stop deceleration	Variable	UNSIGNED32

Table 244: Object Description (6085_h)

Entry Description				
Sub-index	Access	PDO Mapping	Value Range	Default Value
0	rw	no	UNSIGNED32	51200

Table 245: Entry Description (6085_h)

6.1.17 Object 6086_h: Motion Profile Type

This object indicates the configured type of motion profile used to perform a profiled motion. Set this object to 0 to select trapezoid ramps or to 1 for S-shaped ramps.

Value Definition	
Value	Definition
0	Linear (six-point) ramp, trapezoidal profile
1	S-shaped ramp, defined by object 60A4 _h (section 6.1.18)

Table 246: Value Definitions of Object 6086_h

Object Description			
Index	Name	Object Type	Data Type
6086 _h	Motion profile type	Variable	UNSIGNED16

Table 247: Object Description (6086_h)

Entry Description				
Sub-index	Access	PDO Mapping	Value Range	Default Value
0	rw	no	0/1	0

Table 248: Entry Description (6086_h)

6.1.18 Object 60A4_h: Profile Jerk

This object indicates the configured set of jerk parameters that shall be used during the profile movement. The bow of S-shaped ramps is set here. Object 60A4_h can only be used when S-shaped ramps are selected by setting object 6086_h (section 6.1.17) to 1.



Object Description			
Index	Name	Object Type	Data Type
60A4 _h	Profile Jerk	Array	UNSIGNED32

Table 249: Object Description (60A4_h)

Entry Description					
Sub-index	Description	Access	PDO Mapping	Value Range	Default Value
0	Highest sub-index supported	ro	no	4	4
1	Profile jerk 1	rw	no	0...16777215	0
2	Profile jerk 2	rw	no	0...16777215	0
3	Profile jerk 3	rw	no	0...16777215	0
4	Profile jerk 4	rw	no	0...16777215	0

Table 250: Entry Description (60A4_h)

6.1.19 Object 60F2_h: Positioning Option Code

This object indicates the positioning behaviour in profile position mode. Only bits 0 and 1 (relative option) are supported.

Bit Definitions		
Bit 1	Bit 0	Definition
0	0	Positioning moves shall be performed relative to the preceding (internal absolute) target position.
0	1	Positioning moves shall be performed relative to the actual position demand value (object 6063 _h).
1	0	Positioning moves shall be performed relative to the position actual value (object 6064 _h).
1	1	reserved

Table 251: Bit Definitions of Object 60F2_h

Object Description			
Index	Name	Object Type	Data Type
60F2 _h	Positioning option code	Variable	UNSIGNED16

Table 252: Object Description (60F2_h)

Entry Description				
Sub-index	Access	PDO Mapping	Value Range	Default Value
0	rw	no	UNSIGNED16	0

Table 253: Entry Description (60F2_h)

6.2 How to move a Motor in pp Mode

Here is a little example that shows how to get a motor running in pp mode. In this little example we assume that the module has been reset (and then switched to pre-operational or operational) by NMT commands before. Please note that the values are decimal.

- If you do not have any limit switches connected, first disable the limit switch inputs by writing 3 to object 2005_h.
- Select pp mode by writing 1 to object 6060_h.
- Write 6 to object 6040_h to switch to READY_TO_SWITCH_ON state.
- Write 7 to object 6040_h to switch to SWITCHED_ON state.
- Write 15 to object 6040_h to switch to OPERATION_ENABLED state.
- Write the desired target position (e.g. 500000) to object 607A_h.
- Mark the new target position as active by writing 31 to object 6040_h. The motor starts moving now.
- Reset the activation by writing 15 to object 6040_h (this can be done while the motor is still moving).



7 Profile velocity mode

The profile velocity mode is used to control the velocity of the drive without a special regard of the position. It contains limit functions and trajectory generation.

The profile velocity mode covers the following sub-functions:

- Demand value input via trajectory generator.
- Monitoring of the profile velocity using a window-function.
- Monitoring of velocity actual value using a threshold.

The operation of the reference value generator and its input parameters include:

- Profile velocity
- Profile acceleration
- Profile deceleration
- Emergency stop
- Motion profile type

7.1 Detailed Object Specifications

7.1.1 Object 6040_n: Control Word

This object indicates the received command controlling the power drive system finite state automaton (PDS FSA). The CiA-402 state machine can be controlled using this object. Please refer to figure 12 for detailed information.

In pv mode the control word does not contain any operation mode specific bits.

Structure of the control word											
15	11	10	9	8	7	6	4	3	2	1	0
nu	r	r	h	fr	r	eo	qs	ev	so		
MSB						LSB					

Legend: nu=not used; r=reserved; h=halt; fr=fault reset; eo=enable operation; qs=quick stop; ev=enable voltage; so=switch on.

Table 254: Structure of the Control Word in pv Mode



Command coding						
Command	Bits of control word					Transitions
	Bit 7	Bit 3	Bit 2	Bit 1	Bit 0	
Shutdown	0	x	1	1	0	2,6,8
Switch on	0	0	1	1	1	3
Switch on & enable operation	0	1	1	1	1	3, 4
Disable voltage	0	x	x	0	x	7,9,10,12
Quick stop	0	x	0	1	x	7,10,11
Disable operation	0	0	1	1	1	5
Enable operation	0	1	1	1	1	4, 16
Fault reset	0-to-1	x	x	x	x	15

Table 255: Command Coding

Object Description			
Index	Name	Object Type	Data Type
6040 _h	Controlword	Variable	UNSIGNED16

Table 256: Object Description (6040_h in pv Mode)

Entry Description				
Sub-index	Access	PDO Mapping	Value Range	Default Value
0	rw	see CiA402-3	See command coding above.	

Table 257: Entry Description (6040_h in pv Mode)

7.1.2 Object 6041_h: Status Word

This object provides the status of the PDS FSA. It reflects the status of the CiA-402 state machine. Please refer to figure 12 for detailed information. The object is structured as defined below. For more information about the coding please refer to the CANopen Drives and motion control device profile, part 2.

Structure of the Status Word															
15	14	13	12	11	10	9	8	7	6	5	4	3	2	1	0
dir	mot	oms	ila	tr	rm	ms	w	sod	qs	ve	f	oe	so	rtso	
MSB														LSB	

Legend: nu=not used; r=reserved; oms=operation mode specific; h=halt; fr=fault reset; eo=enable operation; qs=quick stop; ev=enable voltage; so=switch on.

Table 258: Structure of the Status Word in pv Mode



Trinamic Specific Bits		
Bit	Name	Definition
14	Motor activity	0: Motor stands still. 1: Motor rotates.
15	Direction of rotation	This bit shows the direction of rotation.

Table 259: Trinamic Specific Bits

Operation Mode specific Bits in pv Mode		
Bit	Name	Definition
10	Target reached	Indicates that the target speed has been reached.
12	Speed	Not supported.
13	Max. slippage error	Not supported.

Table 260: Operation Mode specific Bits in pv Mode

State Coding	
Status word	FSA state
xxxx xxxx x0xx 0000 _h	Not ready to switch on
xxxx xxxx x1xx 0000 _h	Switch on disabled
xxxx xxxx x01x 0001 _h	Ready to switch on
xxxx xxxx x01x 0011 _h	Switched on
xxxx xxxx x01x 0111 _h	Operation enabled
xxxx xxxx x00x 0111 _h	Quick stop active
xxxx xxxx x0xx 1111 _h	Fault reaction active
xxxx xxxx x0xx 1000 _h	Fault

Table 261: State Coding

Object Description			
Index	Name	Object Type	Data Type
6041 _h	Controlword	Variable	UNSIGNED16

Table 262: Object Description (6041_h in pv Mode)



Entry Description				
Sub-index	Access	PDO Mapping	Value Range	Default Value
0	rw	see CiA402-3	See state coding above	

Table 263: Entry Description (6041_h in pv Mode)

7.1.3 Object 6062_h: Position Demand Value

This object provides the demanded position value. The value is given in microsteps. Object 6062_h indicates the actual position that the motor should have. It is not to be confused with objects 6063_h and 6064_h.

Object Description			
Index	Name	Object Type	Data Type
6062 _h	Position Demand Value	Variable	SIGNED32

Table 264: Object Description (6062_h)

Entry Description				
Sub-index	Access	PDO Mapping	Value Range	Default Value
0	ro	Refer to CiA402-3	SIGNED32	no

Table 265: Entry Description (6062_h)

7.1.4 Object 6063_h: Position Actual Internal Value

This object provides the actual value of the encoder or the motor. Please use the sensor selection object 606A_h (see section 5.1.8) for selecting the motor or the encoder first. Object 6063_h indicates the actual position of the encoder or the motor, re-scaled to the microstep resolution. The value is given in microsteps.

Object Description			
Index	Name	Object Type	Data Type
6063 _h	Position Actual Internal Value	Variable	SIGNED32

Table 266: Object Description (6063_h)

Entry Description				
Sub-index	Access	PDO Mapping	Value Range	Default Value
0	ro	Refer to CiA402-3	SIGNED32	no

Table 267: Entry Description (6063_h)



7.1.5 Object 6064_h: Position Actual Internal Value

This object provides the actual value of the position measurement device. It always contains the same value as object 6063_h.

Object Description			
Index	Name	Object Type	Data Type
6064 _h	Position Actual Internal Value	Variable	SIGNED32

Table 268: Object Description (6064_h)

Entry Description				
Sub-index	Access	PDO Mapping	Value Range	Default Value
0	ro	Refer to CiA402-3	SIGNED32	no

Table 269: Entry Description (6064_h)

7.1.6 Object 6065_h: Following Error Window

This object indicates the configured range of tolerated position values symmetrically to the position demand value. If the position actual value is out of the following error window, a following error occurs. A following error may occur when a drive is blocked, unreachable profile velocity occurs, or at wrong closed-loop coefficients. The value shall be given in microsteps.

When the difference between motor position (object 6062_h) and encoder position (object 6063_h or 6064_h) is greater than the value set here, the motor will be stopped and an emergency message will be sent. Setting this object to zero will turn off this feature completely.

Note Setting this object to a too low value will lead to false alarms.

Object Description			
Index	Name	Object Type	Data Type
6065 _h	Following Error Window	Variable	UNSIGNED32

Table 270: Object Description (6065_h)

Entry Description				
Sub-index	Access	PDO Mapping	Value Range	Default Value
0	rw	no	0...2147483647	0

Table 271: Entry Description (6065_h)



7.1.7 Object 606C_h: Velocity Actual Value

This object shows the actual velocity value of the motor. The value is given in internal or user-defined velocity units (depending on object 208C_h, described in section 4.2.35).

Object Description			
Index	Name	Object Type	Data Type
606C _h	Velocity Actual Value	Variable	SIGNED32

Table 272: Object Description (606C_h)

Entry Description				
Sub-index	Access	PDO Mapping	Value Range	Default Value
0	ro	Refer to CiA402-3	SIGNED32	no

Table 273: Entry Description (606C_h)

7.1.8 Object 607D_h: Software Position Limit

This object indicates the configured maximal and minimal software position limits. These parameters define the absolute position limits for the position demand value and the position actual value. Every new target position is checked against these limits. The limit positions are always relative to the machine home position. Before being compared with the target position, they are corrected internally by the home offset as follows:

$$\text{Corrected_min_position_limit} = \text{min_position_limit} - \text{home_offset}$$

$$\text{Corrected_max_position_limit} = \text{max_position_limit} - \text{home_offset}$$

Object Description			
Index	Name	Object Type	Data Type
607D _h	Software Position Limit	Array	SIGNED32

Table 274: Object Description (607D_h)

Entry Description					
Sub-index	Description	Access	PDO Mapping	Value Range	Default Value
1	Minimum Position Limit	rw	no	SIGNED32	-2147483648
2	Maximum Position Limit	rw	no	SIGNED32	2147483647

Table 275: Entry Description (607D_h)



7.1.9 Object 6083_h: Profile Acceleration

This object indicates the configured acceleration. Object 6083_h sets the maximum acceleration to be used in profile positioning and in profile velocity mode.

The units for object 6083_h can be chosen with object 208E_h, described in section 4.2.36.

Object Description			
Index	Name	Object Type	Data Type
6083 _h	Profile Acceleration	Variable	SIGNED32

Table 276: Object Description (6083_h)

Entry Description				
Sub-index	Access	PDO Mapping	Value Range	Default Value
0	rw	no	SIGNED32	0

Table 277: Entry Description (6083_h)

7.1.10 Object 6084_h: Profile Deceleration

This object indicates the configured deceleration. Object 6084_h sets the maximum deceleration to be used in profile positioning mode and in profile velocity mode.

The units for object 6084_h can be chosen with object 208E_h, described in section 4.2.36.

Object Description			
Index	Name	Object Type	Data Type
6084 _h	Profile Deceleration	Variable	SIGNED32

Table 278: Object Description (6084_h)

Entry Description				
Sub-index	Access	PDO Mapping	Value Range	Default Value
0	rw	no	SIGNED32	0

Table 279: Entry Description (6084_h)

7.1.11 Object 6085_h: Quick Stop Deceleration

This object indicates the configured deceleration used to stop the motor when the quick stop function is activated and the quick stop code object 605A_h is set to 2 (or 6). The value is given in the same unit as profile acceleration object 6083_h.



Object Description			
Index	Name	Object Type	Data Type
6085 _h	Quick stop deceleration	Variable	UNSIGNED32

Table 280: Object Description (6085_h)

Entry Description				
Sub-index	Access	PDO Mapping	Value Range	Default Value
0	rw	no	UNSIGNED32	51200

Table 281: Entry Description (6085_h)

7.1.12 Object 6086_h: Motion Profile Type

This object indicates the configured type of motion profile used to perform a profiled motion. Set this object to 0 to select trapezoid ramps or to 1 for S-shaped ramps.

Value Definition	
Value	Definition
0	Linear (six-point) ramp, trapezoidal profile
1	S-shaped ramp, defined by object 60A4 _h (section 7.1.13)

Table 282: Value Definitions of Object 6086_h

Object Description			
Index	Name	Object Type	Data Type
6086 _h	Motion profile type	Variable	UNSIGNED16

Table 283: Object Description (6086_h)

Entry Description				
Sub-index	Access	PDO Mapping	Value Range	Default Value
0	rw	no	0/1	0

Table 284: Entry Description (6086_h)

7.1.13 Object 60A4_h: Profile Jerk

This object indicates the configured set of jerk parameters that shall be used during the profile movement. The bow of S-shaped ramps is set here. Object 60A4_h can only be used when S-shaped ramps are selected by setting object 6086_h (section 7.1.12) to 1.



Object Description			
Index	Name	Object Type	Data Type
60A4 _h	Profile Jerk	Array	UNSIGNED32

Table 285: Object Description (60A4_h)

Entry Description					
Sub-index	Description	Access	PDO Mapping	Value Range	Default Value
0	Highest sub-index supported	ro	no	4	4
1	Profile jerk 1	rw	no	0...16777215	0
2	Profile jerk 2	rw	no	0...16777215	0
3	Profile jerk 3	rw	no	0...16777215	0
4	Profile jerk 4	rw	no	0...16777215	0

Table 286: Entry Description (60A4_h)

7.1.14 Object 60FF_h: Target Velocity

This object indicates the configured target velocity and is used as input for the trajectory generator. Object 60FF_h sets the target velocity when using profile velocity mode. The drive then accelerates or decelerates to that velocity using the acceleration and deceleration set by objects 6083_h and 6084_h. The values are given in units which can be selected with object 208C_h, described in section 4.2.35.

Object Description			
Index	Name	Object Type	Data Type
60FF _h	Target Velocity	Variable	SIGNED32

Table 287: Object Description (60FF_h)

Entry Description				
Sub-index	Access	PDO Mapping	Value Range	Default Value
0	rw	see CiA402-3	SIGNED32	0

Table 288: Entry Description (60FF_h)

7.2 How to move a Motor in pv Mode

Here is a little example that shows how to get a motor running in pv mode. In this little example we assume that the module has been reset (and then switched to pre-operational or operational) by NMT commands before.

- If you do not have any limit switches connected, first disable the limit switch inputs by writing 3 to object 2005_h.



- Select pv mode by writing 3 to object 6060_h.
- Write 6 to object 6040_h to switch to READY_TO_SWITCH_ON state.
- Write 7 to object 6040_h to switch to SWITCHED_ON state.
- Write 15 to object 6040_h to switch to OPERATION_ENABLED state.
- Write the desired target speed (e.g. 100000) to object 60FF_h. The motor now accelerates to that speed.
- Stop the motor by writing 0 to object 60FF_h.



8 Homing mode

This chapter describes the method by which a drive seeks the home position (reference point). There are various methods of achieving this using limit switches at the ends of travel or a home switch in mid-travel. Some methods also use the index (zero) pulse train from an incremental encoder. The user may specify the speeds, acceleration and the method of homing.

There is no output data except for those bits in the statusword which return the status or result of the homing process and the demand to the position control loops.

There are four sources of the homing signal available: these are positive and negative limit switches, the home switch and the index pulse from an encoder.

Figure 13 shows the defined input objects as well as the output objects. The user can specify the speeds, acceleration and method of homing. The home offset object 607C_h allows displacing the zero in point the coordinate system for the home position.

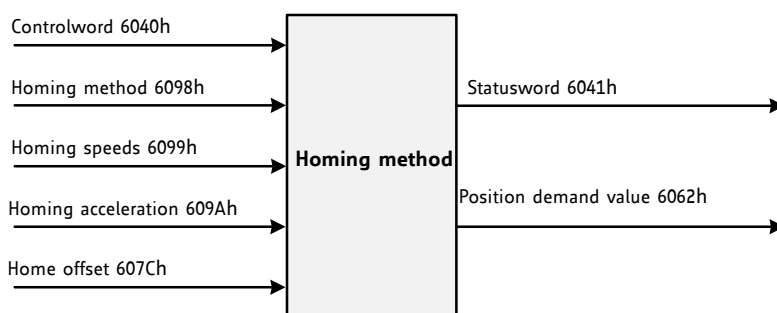

Figure 13: Homing Mode Function

Choosing a homing mode determines the following things:

- The homing signal (positive limit switch, negative limit switch, and home switch).
- The direction of actuation where appropriate.
- The position of the index pulse.

The home position and the zero position are offset by the home offset (see object 607C_h, section 8.2.4).

There are four sources of homing signals available:

- Negative and positive limit switches.
- Home switch.
- Index pulse of an encoder.

For the operation of positioning drives, an exact knowledge of the absolute position is normally required. Since for cost reasons drives often do not have an absolute encoder, a homing operation is necessary.

8.1 Homing Methods

The TMC3315 supports a subset of different standard CANopen homing methods. The homing method that is to be used can be chosen via object 6098_h (section 8.2.5).



Supported Homing Methods	
Method	Description
0	No homing (default value for object 6098 _h).
1	Search the left end switch, then search the next encoder index pulse.
2	Search the right end switch, then search the next encoder index pulse.
3	Search the positive edge of the home switch, then search the next encoder index pulse.
5	Search the negative edge of the home switch, then search the next encoder index pulse.
17	Search the left end switch.
18	Search the right end switch.
19	Search the positive edge of the home switch.
21	Search the negative edge of the home switch.
33	Search next index pulse in negative direction.
34	Search next index pulse in positive direction.
35	The actual position is used as home position. All position values (objects 6062 _h , 6063 _h , and 6064 _h) are set to zero, but the motor will not move.

Table 289: Supported CANopen Homing Methods

When using homing methods that need end switch inputs or home switch inputs please take care of their configuration (object 2005_h, section 4.2.6).

8.1.1 Homing Method 1: Homing on negative Limit Switch and Index Pulse

Using this method, the initial direction of movement shall be leftward if the negative limit switch is inactive (here: low). The home position shall be at the first index pulse to the right of the position where the negative limit switch becomes inactive.

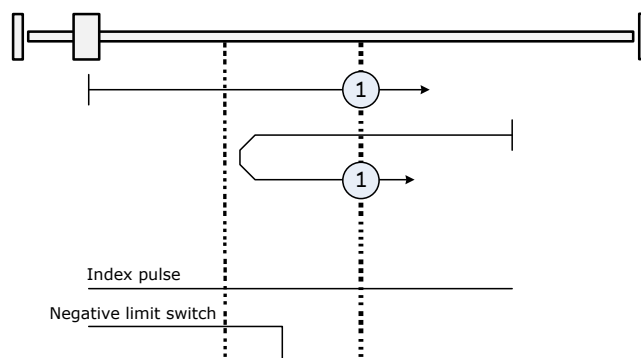

Figure 14: Homing Method 1

8.1.2 Homing Method 2: Homing on positive Limit Switch and Index Pulse

Using this method, the initial direction of movement shall be rightward if the positive limit switch is inactive (here: low). The position of home shall be at the first index pulse to the left of the position where the positive limit switch becomes inactive.



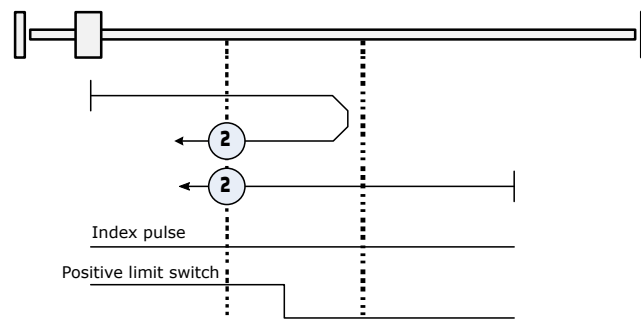

Figure 15: Homing Method 2

8.1.3 Homing Method 3: Homing on positive Home Switch and Index Pulse

Using this method, the initial direction of movement shall be dependent on the state of the home switch. The home position shall be at the index pulse to either to the left or the right of the point where the home switch changes state. If the initial position is situated so that the direction of movement shall reverse during homing, the point at which the reversal takes place is anywhere after a change of state of the home switch.

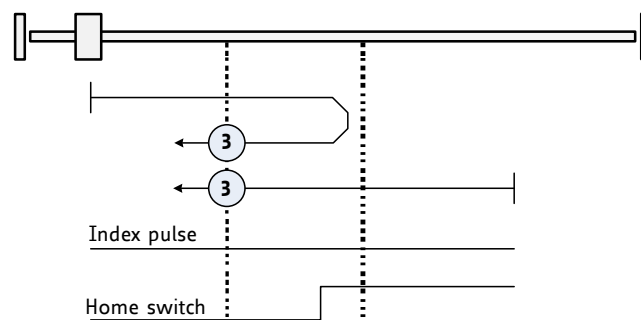

Figure 16: Homing Method 3

8.1.4 Homing Method 5: Homing on negative Home Switch and Index Pulse

Using this method, the initial direction of movement shall be dependent on the state of the home switch. The home position shall be at the index pulse to either to the left or the right of the point where the home switch changes state. If the initial position is situated so that the direction of movement shall reverse during homing, the point at which the reversal takes place is anywhere after a change of state of the home switch.



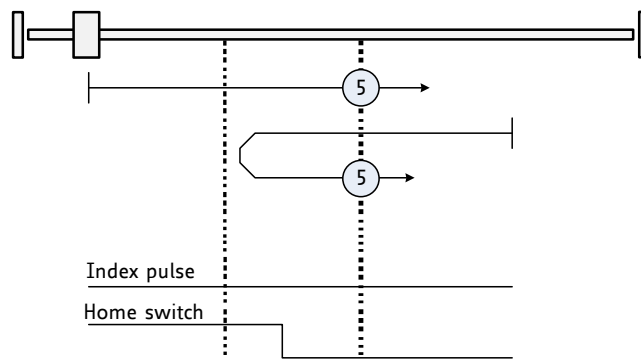

Figure 17: Homing Method 5

8.1.5 Homing Method 17, 18, 19, and 21: Homing without Index Pulse

These methods are similar to methods 1 to 5 except that the home position is not dependent on the index pulse but only dependent on the relevant home or limit switch transitions. As an example, homing method 19 (which is similar to homing method 3) is shown in figure 18.

Homing Methods 17... 21	
Method	Description
17	Search the left end switch. (Similar to method 1)
18	Search the right end switch. (Similar to method 2)
19	Search the positive edge of the home switch. (Similar to method 3)
21	Search the negative edge of the home switch. (Similar to method 5.)

Table 290: Homing Methods 17 - 21

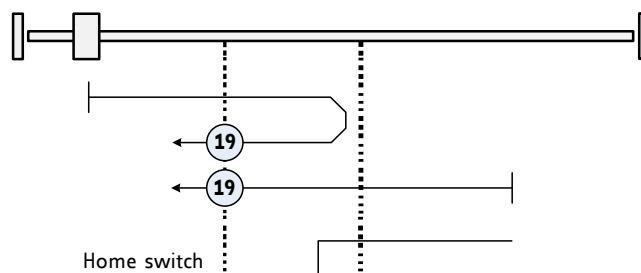

Figure 18: Homing Method 19

8.1.6 Homing Method 33 and 34: Homing on next Index Pulse

Using these methods, the direction of homing is negative or positive respectively. The home position shall be at the index pulse found in the selected direction as shown in Figure 4.10.



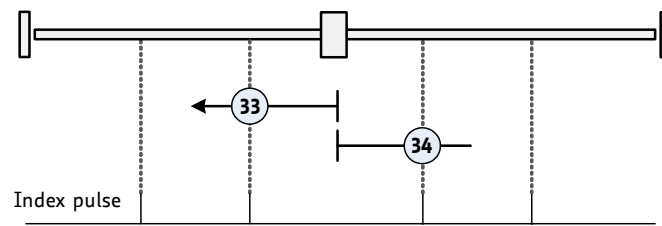

Figure 19: Homing Methods 33 and 34

8.1.7 Homing Method 35: Current position as home position

In this method, the current position shall be taken to be the home position. This method does not require the drive device to be in operation enabled state.



8.2 Detailed Object Specifications

8.2.1 Object 6040_h: Control Word

This object indicates the received command controlling the power drive system finite state automaton (PDS FSA). The CiA-402 state machine can be controlled using this object. Please refer to figure 12 for detailed information.

Structure of the control word											
15	11	10	9	8	7	6	4	3	2	1	0
nu	r	oms	h	fr	oms	eo	qs	ev	so		
MSB						LSB					

Legend: nu=not used; r=reserved; oms=operation mode specific; h=halt; fr=fault reset; eo=enable operation; qs=quick stop; ev=enable voltage; so=switch on.

Table 291: Structure of the Control Word in hm Mode

Operation mode specific bits in hm mode		
Bit	Name	Definition
4	Homing operation start	1: start homing; 0: stop homing
8	Halt	Not supported.

Table 292: Operation Mode specific Bits in hm Mode

Command coding						
Command	Bits of control word					Transitions
	Bit 7	Bit 3	Bit 2	Bit 1	Bit 0	
Shutdown	0	x	1	1	0	2,6,8
Switch on	0	0	1	1	1	3
Switch on & enable operation	0	1	1	1	1	3, 4
Disable voltage	0	x	x	0	x	7,9,10,12
Quick stop	0	x	0	1	x	7,10,11
Disable operation	0	0	1	1	1	5
Enable operation	0	1	1	1	1	4, 16
Fault reset	0-to-1	x	x	x	x	15

Table 293: Command Coding



Object Description			
Index	Name	Object Type	Data Type
6040 _h	Controlword	Variable	UNSIGNED16

Table 294: Object Description (6040_h in hm Mode)

Entry Description				
Sub-index	Access	PDO Mapping	Value Range	Default Value
0	rw	see CiA402-3	See command coding above.	

Table 295: Entry Description (6040_h in hm Mode)

8.2.2 Object 6041_h: Status Word

This object provides the status of the PDS FSA. It reflects the status of the CiA-402 state machine. Please refer to figure 12 for detailed information. The object is structured as defined below. For more information about the coding please refer to the CANopen Drives and motion control device profile, part 2.

Structure of the Status Word															
15	14	13	12	11	10	9	8	7	6	5	4	3	2	1	0
dir	mot	oms	ila	tr	rm	ms	w	sod	qs	ve	f	oe	so	rtso	
MSB														LSB	

Legend: nu=not used; r=reserved; oms=operation mode specific; h=halt; fr=fault reset; eo=enable operation; qs=quick stop; ev=enable voltage; so=switch on.

Table 296: Structure of the Status Word in hm Mode

Trinamic Specific Bits		
Bit	Name	Definition
14	Motor activity	0: Motor stands still. 1: Motor rotates.
15	Direction of rotation	This bit shows the direction of rotation.

Table 297: Trinamic Specific Bits



Operation Mode specific Bits in hm Mode		
Bit	Name	Definition
10	Target reached	Set when the zero position has been found or homing has been stopped by setting controlword bit 4 to zero.
12	Home attained	Set when zero position has been found.
13	Homing error	Not supported.

Table 298: Operation Mode specific Bits in hm Mode

State Coding	
Status word	FSA state
xxxx xxxx x0xx 0000 _h	Not ready to switch on
xxxx xxxx x1xx 0000 _h	Switch on disabled
xxxx xxxx x01x 0001 _h	Ready to switch on
xxxx xxxx x01x 0011 _h	Switched on
xxxx xxxx x01x 0111 _h	Operation enabled
xxxx xxxx x00x 0111 _h	Quick stop active
xxxx xxxx x0xx 1111 _h	Fault reaction active
xxxx xxxx x0xx 1000 _h	Fault

Table 299: State Coding

Object Description			
Index	Name	Object Type	Data Type
6041 _h	Controlword	Variable	UNSIGNED16

Table 300: Object Description (6041_h in hm Mode)

Entry Description				
Sub-index	Access	PDO Mapping	Value Range	Default Value
0	rw	see CiA402-3	See state coding above.	

Table 301: Entry Description (6041_h in hm Mode)

8.2.3 Object 606C_h: Velocity Actual Value

This object shows the actual velocity value of the motor. The value is given in internal or user-defined velocity units (depending on object 208C_h, described in section 4.2.35).



Object Description			
Index	Name	Object Type	Data Type
606C _h	Velocity Actual Value	Variable	SIGNED32

Table 302: Object Description (606C_h)

Entry Description				
Sub-index	Access	PDO Mapping	Value Range	Default Value
0	ro	Refer to CiA402-3	SIGNED32	no

Table 303: Entry Description (606C_h)

8.2.4 Object 607C_h: Home Offset

This object indicates the configured difference between the zero position for the application and the machine home position/home switch (found during homing). While homing, the machine home position is found and once the homing is completed, the zero position is offset from the home position by adding the home offset to the home position. The effect of setting the home position to a non-zero value depends on the selected homing method. The value of this object is given in microsteps. Negative values indicate the opposite direction.

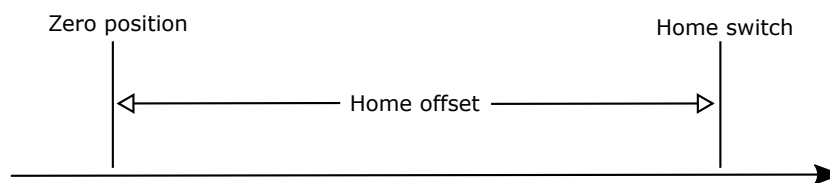

Figure 20: Home Offset

Object Description			
Index	Name	Object Type	Data Type
607C _h	Home offset	Variable	SIGNED32

Table 304: Object Description (607C_h)

Entry Description				
Sub-index	Access	PDO Mapping	Value Range	Default Value
0	rw	no	SIGNED32	0

Table 305: Entry Description (607C_h)



8.2.5 Object 6098_h: Homing Method

The homing method to be used can be selected by writing to this object. Please see table 289 for a list of homing methods supported by the current version of the TMCM-3315 CANopen firmware.

Object Description			
Index	Name	Object Type	Data Type
6098 _h	Homing method	Variable	SIGNED8

Table 306: Object Description (6098_h)

Entry Description				
Sub-index	Access	PDO Mapping	Value Range	Default Value
0	rw	no	SIGNED8	0

Table 307: Entry Description (6098_h)

8.2.6 Object 6099_h: Homing Speeds

This object indicates the configured speeds used during homing procedure. The values are given in pps units or inernal units selectable with object 208C_h (section 4.2.35). Using object 6099_h a fast and a slow homing speed can be set. In most homing modes, the home switch is searched with the fast speed first. When the home switch has been found, the motor will be decelerated to the slow speed (using the homing acceleration, object 609A_h) to search for the exact switch point. When the switch point has been found the motor will be stopped at that point.

Object Description			
Index	Name	Object Type	Data Type
6099 _h	Homing speeds	Array	UNSIGNED32

Table 308: Object Description (6099_h)

Entry Description					
Sub-index	Description	Access	PDO Mapping	Value Range	Default Value
1	Fast homing speed	rw	no	UNSIGNED32	0
2	Slow homing speed	rw	no	UNSIGNED32	0

Table 309: Entry Description (6099_h)

8.2.7 Object 609A_h: Homing Acceleration

This object indicates the configured acceleration and deceleration to be used during homing operation. The value set here will be used for acceleration and for deceleration during homing. The value is given in



units selected by object 208E_h (section 4.2.36).

Object Description			
Index	Name	Object Type	Data Type
609A _h	Homing acceleration	Variable	UNSIGNED32

Table 310: Object Description (609A_h)

Entry Description				
Sub-index	Access	PDO Mapping	Value Range	Default Value
0	rw	no	UNSIGNED32	0

Table 311: Entry Description (609A_h)

8.2.8 Object 2100_h: Home Offset Display

This object shows the home offset. The value is given in microsteps.

Object Description			
Index	Name	Object Type	Data Type
2100 _h	Home Offset Display	Variable	SIGNED32

Table 312: Object Description (2100_h)

Entry Description				
Sub-index	Access	PDO Mapping	Value Range	Default Value
0	ro	no	-2147483648...2147483647	0

Table 313: Entry Description (2100_h)

8.3 How to start a Homing in hm Mode

Here is a little example that shows how to home the motor in hm mode. In this little example we assume that the module has been reset (and then switched to pre-operational or operational) by NMT commands before. The home switch must be connected to the home switch input. It can be operated manually.

- Select hm mode by writing 6 to object 6060_h.
- Write 6 to object 6040_h to switch to READY_TO_SWITCH_ON state.
- Write 7 to object 6040_h to switch to SWITCHED_ON state.
- Write 15 to object 6040_h to switch to OPERATION_ENABLED state.



- Select homing method 19 by writing 19 to object 6098_h.
- Set the homing speeds by writing e.g. 50000 to object 6099_h sub index 1 and e.g. 10000 to object 6099_h sub index 2.
- Write 31 to object 6040_h to start the homing process.
- Press and release the home switch.
- When homing has finished, write 15 to object 6040_h again.



9 Emergency Messages (EMCY)

The module sends an emergency message if an error occurs. The message contains information about the error type. The module can map internal errors and object 1001_h (error register) is part of every emergency object.

Please note that the additional byte #2 shows which motor is affected.

Emergency Messages (EMCY) of the TMC3315						
Error code	Additional byte					Description
	1	2	3	4	5	
0000 _h	0	0...2	0	0	0	Fault reset The fault reset command has been executed.
1000 _h	1	0...2	0	0	0	Generic error: open load bridge A The motor driver indicates open load on bridge A. It is possible that the motor cable is broken or that there is an error in the power amplifier itself.
1000 _h	2	0...2	0	0	0	Generic error: open load bridge B The motor driver indicates open load on bridge B. It is possible that the motor cable is broken or that there is an error in the power amplifier itself.
2310 _h	0	0...2	0	0	0	Overcurrent high side The motor driver indicates an overcurrent on the high side. This can be caused by a short circuit in the driver stage.
2311 _h	0	0...2	0	0	0	Overcurrent bridge B The motor driver indicates that there is overcurrent on bridge B. This can be caused by a short circuit in the motor itself or in the motor driver stage.
2312 _h	0	0...2	0	0	0	Overcurrent bridge A The motor driver indicates that there is overcurrent on bridge A. This can be caused by a short circuit in the motor itself or in the motor driver stage.
3230 _h	0	0...2	0	0	0	stallGuard2 error The actual load value exceeds the stallGuard2 limit.
4310 _h	1	0...2	0	0	0	Overtemperature pre-warning The temperature in the motor driver exceeds the pre-warning limit.
4310 _h	2	0...2	0	0	0	Overtemperature error The motor driver has been switched off because the temperature limit has been exceeded.
5441 _h	0	255	0	0	0	Shutdown switch active The enable signal is missing (due to the shutdown switch) and the motor driver has been switched off.
6320 _h	0	255	0	0	0	Parameter error The data in the received PDO is either wrong or cannot be accepted due to the internal state of the drive.



Error code	Additional byte					Description
	1	2	3	4	5	
8611 _h	0	0...2	0	0	0	Following error The deviation between motor position counter and encoder position counter has exceeded the following error window.
ff00 _h	0	0...2	0	0	0	Undervoltage The supply voltage is too low to drive a motor.
ff01 _h	1	0...2	0	0	0	Positive software limit The actual position is outside the range defined by object 607d _h .
ff01 _h	2	0...2	0	0	0	Negative software limit The actual position is outside the range defined by object 607d _h .
ff01 _h	3	0...2	0	0	0	Positive limit switch The positive limit switch has been touched outside of the homing function.
ff01 _h	4	0...2	0	0	0	Negative limit switch The negative limit switch has been touched outside of the homing function.

Table 314: Emergency Messages (EMCY)



10 Figures Index

1	stallGuard2 Load Measurement as a Function of Load	5	11	Brake Output Timing	28
2	Energy Efficiency Example with coolStep	6	12	DS402 Finite State Machine	68
3	Closed-Loop Control Scheme	8	13	Homing Mode Function	91
4	Load Angle Control Parameter	8	14	Homing Method 1	92
5	Current Level Control	9	15	Homing Method 2	93
6	Field Weakening	10	16	Homing Method 3	93
7	Position Catch up	10	17	Homing Method 5	94
8	NMT State Machine	13	18	Homing Method 19	94
9	Device Model	14	19	Homing Methods 33 and 34	95
10	coolStep Adjustment Points and Thresholds	25	20	Home Offset	99



11 Tables Index

1	Abbreviations used in this Manual . . .	4	52	Object Description (2010 _h)	31
2	Closed-Loop Example Settings	7	53	Entry Description (2010 _h)	32
3	Service Primitives	11	54	Object Description (2011 _h)	32
4	Service Types	12	55	Entry Description (2011 _h)	32
5	Object Dictionary	15	56	Object Description (2012 _h)	32
6	Multi-Axis Object Indices	16	57	Entry Description (2012 _h)	32
7	Object Description (1000 _h)	17	58	Object Description (2013 _h)	33
8	Entry Description (1000 _h)	17	59	Entry Description (2013 _h)	33
9	Object Description (1001 _h)	17	60	Object Description (2014 _h)	33
10	Entry Description (1001 _h)	17	61	Entry Description (2014 _h)	33
11	Error Register Bits	18	62	Object Description (2020 _h)	34
12	Object Description (1008 _h)	18	63	Entry Description (2020 _h)	34
13	Entry Description (1008 _h)	18	64	Object Description (2021 _h)	34
14	Object Description (1009 _h)	18	65	Entry Description (2021 _h)	34
15	Entry Description (1009 _h)	19	66	Object Description (2022 _h)	34
16	Object Description (100A _h)	19	67	Entry Description (2022 _h)	35
17	Entry Description (100A _h)	19	68	Object Description (2027 _h)	35
18	Object Description (1018 _h)	19	69	Entry Description (2027 _h)	35
19	Entry Description (1018 _h)	20	70	Object Description (2028 _h)	35
20	Object Description (1600 _h)	20	71	Entry Description (2028 _h)	35
21	Entry Description (1600 _h)	20	72	Object Description (2029 _h)	36
22	Object Description (1A00 _h)	21	73	Entry Description (2029 _h)	36
23	Entry Description (1A00 _h)	21	74	Object Description (202A _h)	36
24	Sync Manager Communication Types	22	75	Entry Description (202A _h)	36
25	Object Description (1C00 _h)	22	76	Object Description (202B _h)	36
26	Entry Description (1C00 _h)	22	77	Entry Description (202B _h)	37
27	Object Description (1C12 _h)	22	78	Object Description (202C _h)	37
28	Entry Description (1C12 _h)	23	79	Entry Description (202C _h)	37
29	Object Description (1C13 _h)	23	80	Object Description (202D _h)	37
30	Entry Description (1C13 _h)	23	81	Entry Description (202D _h)	37
31	Multi-axis Object Indices (Manufacturer specific Area)	24	82	Object Description (202E _h)	38
32	coolStep related Objects	26	83	Entry Description (202E _h)	38
33	Object Description (2000 _h)	27	84	Object Description (202F _h)	38
34	Entry Description (2000 _h)	27	85	Entry Description (202F _h)	38
35	Object Description (2001 _h)	27	86	Object Description (2030 _h)	38
36	Entry Description (2001 _h)	27	87	Entry Description (2030 _h)	39
37	Object Description (2002 _h)	28	88	Object Description (2031 _h)	39
38	Entry Description (2002 _h)	28	89	Entry Description (2031 _h)	39
39	Object Description (2003 _h)	28	90	Object Description (2033 _h)	39
40	Entry Description (2003 _h)	28	91	Entry Description (2033 _h)	39
41	Object Description (2004 _h)	29	92	Object Description (2034 _h)	40
42	Entry Description (2004 _h)	29	93	Entry Description (2034 _h)	40
43	Object Description (2005 _h)	29	94	Object Description (2035 _h)	40
44	Entry Description (2005 _h)	29	95	Entry Description (2035 _h)	40
45	Bit Definitions (2005 _h)	30	96	Object Description (2036 _h)	40
46	Object Description (200A _h)	30	97	Entry Description (2036 _h)	41
47	Entry Description (200A _h)	30	98	Object Description (204E _h)	41
48	Object Description (200B _h)	30	99	Entry Description (204E _h)	41
49	Entry Description (200B _h)	31	100	Object Description (2089 _h)	41
50	Object Description (200C _h)	31	101	Entry Description (2089 _h)	41
51	Entry Description (200C _h)	31	102	Object Description (208C _h)	42
			103	Entry Description (208C _h)	42



104	Object Description (208E _h)	42	158	Object Description (2702 _h)	55
105	Entry Description (208E _h)	42	159	Entry Description (2702) _h	55
106	Object Description (2092 _h)	43	160	Bit Definitions (2703 _h)	55
107	Entry Description (2092 _h)	43	161	Object Description (2703 _h)	56
108	Object Description (2093 _h)	43	162	Entry Description (2703 _h)	56
109	Entry Description (2093 _h)	43	163	Object Description (2704 _h)	56
110	Object Description (2094 _h)	43	164	Entry Description (2704) _h	56
111	Entry Description (2094 _h)	44	165	Object Description (2705 _h)	57
112	Object Description (2095 _h)	44	166	Entry Description (2705) _h	57
113	Entry Description (2095 _h)	44	167	Object Description (2706 _h)	57
114	Object Description (2096 _h)	44	168	Entry Description (2706) _h	57
115	Entry Description (2096 _h)	45	169	Object Description (2707 _h)	58
116	Object Description (2097 _h)	45	170	Entry Description (2707) _h	58
117	Entry Description (2097 _h)	45	171	Object Description (2708 _h)	58
118	Object Description (2098 _h)	45	172	Entry Description (2708 _h)	58
119	Entry Description (2098 _h)	46	173	Object Description (270E _h)	58
120	Object Description (2099 _h)	46	174	Entry Description (270E _h)	59
121	Entry Description (2099 _h)	46	175	Multi-axis Object Indices (Profile specific Area)	60
122	Object Description (209A _h)	46	176	Value Description (605A _h)	61
123	Entry Description (209A _h)	47	177	Object Description (605A _h)	61
124	Object Description (209B _h)	47	178	Entry Description (605A _h)	61
125	Entry Description (209B _h)	47	179	Value Description (605B _h)	61
126	Object Description (209C _h)	47	180	Object Description (605B _h)	61
127	Entry Description (209C _h)	48	181	Entry Description (605B _h)	62
128	Object Description (209D _h)	48	182	Value Description (605C _h)	62
129	Entry Description (209D _h)	48	183	Object Description (605C _h)	62
130	Object Description (209E _h)	48	184	Entry Description (605C _h)	62
131	Entry Description (209E _h)	49	185	Value Description (605D _h)	62
132	Object Description (20A1 _h)	49	186	Object Description (605D _h)	63
133	Entry Description (20A1 _h)	49	187	Entry Description (605D _h)	63
134	Object Description (20A3 _h)	49	188	Value Description (605E _h)	63
135	Entry Description (20A3 _h)	50	189	Object Description (605E _h)	63
136	Object Description (20A4 _h)	50	190	Entry Description (605E _h)	63
137	Entry Description (20A4 _h)	50	191	Value Description (6060 _h)	64
138	Object Description (20A5 _h)	50	192	Object Description (6060 _h)	64
139	Entry Description (20A5 _h)	50	193	Entry Description (6060 _h)	64
140	Object Description (2100 _h)	51	194	Value Description (6061 _h)	64
141	Entry Description (2100 _h)	51	195	Object Description (6061 _h)	65
142	Object Description (2101 _h)	51	196	Entry Description (6061 _h)	65
143	Entry Description (2101 _h)	51	197	Value Description (606A _h)	65
144	Driver Error Flags (2102 _h)	52	198	Object Description (606A _h)	65
145	Object Description (2102 _h)	52	199	Entry Description (606A _h)	65
146	Entry Description (2102 _h)	52	200	Object Description (608F _h)	66
147	Object Description (2107 _h)	52	201	Entry Description (608F _h)	66
148	Entry Description (2107 _h)	53	202	Object Description (60FD _h)	66
149	Object Description (210B _h)	53	203	Entry Description (60FD _h)	66
150	Entry Description (210B _h)	53	204	Value Definition (6502 _h)	67
151	Object Description (2120 _h)	53	205	Object Description (6502 _h)	67
152	Entry Description (2120 _h)	53	206	Entry Description (6502 _h)	67
153	Object Description (2700 _h)	54	207	Structure of the Control Word in pp Mode	69
154	Entry Description (2700) _h	54	208	Operation Mode specific Bits in pp Mode	69
155	Object Description (2701 _h)	54	209	Command Coding	69
156	Entry Description (2701) _h	54			
157	Bit Definitions (2702 _h)	55			



210	Object Description (6040 _h in pp Mode)	70	263	Entry Description (6041 _h in pv Mode)	84
211	Entry Description (6040 _h in pp Mode)	70	264	Object Description (6062 _h)	84
212	Structure of the Staus Word in pp Mode	70	265	Entry Description (6062 _h)	84
213	Trinamic Specific Bits	70	266	Object Description (6063 _h)	84
214	Operation Mode specific Bits in pp Mode	71	267	Entry Description (6063 _h)	84
215	State Coding	71	268	Object Description (6064 _h)	85
216	Object Description (6041 _h in pp Mode)	71	269	Entry Description (6064 _h)	85
217	Entry Description (6041 _h in pp Mode)	71	270	Object Description (6065 _h)	85
218	Object Description (6062 _h)	72	271	Entry Description (6065 _h)	85
219	Entry Description (6062 _h)	72	272	Object Description (606C _h)	86
220	Object Description (6063 _h)	72	273	Entry Description (606C _h)	86
221	Entry Description (6063 _h)	72	274	Object Description (607D _h)	86
222	Object Description (6064 _h)	72	275	Entry Description (607D _h)	86
223	Entry Description (6064 _h)	73	276	Object Description (6083 _h)	87
224	Object Description (6065 _h)	73	277	Entry Description (6083 _h)	87
225	Entry Description (6065 _h)	73	278	Object Description (6084 _h)	87
226	Object Description (6067 _h)	74	279	Entry Description (6084 _h)	87
227	Entry Description (6067 _h)	74	280	Object Description (6085 _h)	88
228	Object Description (6068 _h)	74	281	Entry Description (6085 _h)	88
229	Entry Description (6068 _h)	74	282	Value Definitions of Object 6086 _h	88
230	Object Description (606C _h)	74	283	Object Description (6086 _h)	88
231	Entry Description (606C _h)	75	284	Entry Description (6086 _h)	88
232	Object Description (607A _h in pp Mode)	75	285	Object Description (60A4 _h)	89
233	Entry Description (607A _h in pp Mode)	75	286	Entry Description (60A4 _h)	89
234	Object Description (607D _h)	75	287	Object Description (60FF _h)	89
235	Entry Description (607D _h)	76	288	Entry Description (60FF _h)	89
236	Object Description (6081 _h)	76	289	Supported CANopen Homing Methods	92
237	Entry Description (6081 _h)	76	290	Homing Methods 17 – 21	94
238	Object Description (6082 _h)	76	291	Structure of the Control Word in hm Mode	96
239	Entry Description (6082 _h)	76	292	Operation Mode specific Bits in hm Mode	96
240	Object Description (6083 _h)	77	293	Command Coding	96
241	Entry Description (6083 _h)	77	294	Object Description (6040 _h in hm Mode)	97
242	Object Description (6084 _h)	77	295	Entry Description (6040 _h in hm Mode)	97
243	Entry Description (6084 _h)	77	296	Structure of the Status Word in hm Mode	97
244	Object Description (6085 _h)	78	297	Trinamic Specific Bits	97
245	Entry Description (6085 _h)	78	298	Operation Mode specific Bits in hm Mode	98
246	Value Definitions of Object 6086 _h	78	299	State Coding	98
247	Object Description (6086 _h)	78	300	Object Description (6041 _h in hm Mode)	98
248	Entry Description (6086 _h)	78	301	Entry Description (6041 _h in hm Mode)	98
249	Object Description (60A4 _h)	79	302	Object Description (606C _h)	99
250	Entry Description (60A4 _h)	79	303	Entry Description (606C _h)	99
251	Bit Definitions of Object 60F2 _h	79	304	Object Description (607C _h)	99
252	Object Description (60F2 _h)	79	305	Entry Description (607C _h)	99
253	Entry Description (60F2 _h)	80	306	Object Description (6098 _h)	100
254	Structure of the Control Word in pv Mode	81	307	Entry Description (6098 _h)	100
255	Command Coding	82	308	Object Description (6099 _h)	100
256	Object Description (6040 _h in pv Mode)	82	309	Entry Description (6099 _h)	100
257	Entry Description (6040 _h in pv Mode)	82	310	Object Description (609A _h)	101
258	Structure of the Status Word in pv Mode	82	311	Entry Description (609A _h)	101
259	Trinamic Specific Bits	83	312	Object Description (2100 _h)	101
260	Operation Mode specific Bits in pv Mode	83	313	Entry Description (2100 _h)	101
261	State Coding	83			
262	Object Description (6041 _h in pv Mode)	83			



314 Emergency Messages (EMCY)	104	316 Document Revision	109
315 Firmware Revision	109		



12 Supplemental Directives

12.1 Producer Information

12.2 Copyright

TRINAMIC owns the content of this user manual in its entirety, including but not limited to pictures, logos, trademarks, and resources. © Copyright 2016 TRINAMIC. All rights reserved. Electronically published by TRINAMIC, Germany.

Redistributions of source or derived format (for example, Portable Document Format or Hypertext Markup Language) must retain the above copyright notice, and the complete Datasheet User Manual documentation of this product including associated Application Notes; and a reference to other available product-related documentation.

12.3 Trademark Designations and Symbols

Trademark designations and symbols used in this documentation indicate that a product or feature is owned and registered as trademark and/or patent either by TRINAMIC or by other manufacturers, whose products are used or referred to in combination with TRINAMIC's products and TRINAMIC's product documentation.

This CoE Firmware Manual is a non-commercial publication that seeks to provide concise scientific and technical user information to the target user. Thus, trademark designations and symbols are only entered in the Short Spec of this document that introduces the product at a quick glance. The trademark designation /symbol is also entered when the product or feature name occurs for the first time in the document. All trademarks and brand names used are property of their respective owners.

12.4 Target User

The documentation provided here, is for programmers and engineers only, who are equipped with the necessary skills and have been trained to work with this type of product.

The Target User knows how to responsibly make use of this product without causing harm to himself or others, and without causing damage to systems or devices, in which the user incorporates the product.

12.5 Disclaimer: Life Support Systems

TRINAMIC Motion Control GmbH & Co. KG does not authorize or warrant any of its products for use in life support systems, without the specific written consent of TRINAMIC Motion Control GmbH & Co. KG.

Life support systems are equipment intended to support or sustain life, and whose failure to perform, when properly used in accordance with instructions provided, can be reasonably expected to result in personal injury or death.

Information given in this document is believed to be accurate and reliable. However, no responsibility is assumed for the consequences of its use nor for any infringement of patents or other rights of third parties which may result from its use. Specifications are subject to change without notice.

12.6 Disclaimer: Intended Use

The data specified in this user manual is intended solely for the purpose of product description. No representations or warranties, either express or implied, of merchantability, fitness for a particular purpose



or of any other nature are made hereunder with respect to information/specification or the products to which information refers and no guarantee with respect to compliance to the intended use is given.

In particular, this also applies to the stated possible applications or areas of applications of the product. TRINAMIC products are not designed for and must not be used in connection with any applications where the failure of such products would reasonably be expected to result in significant personal injury or death (safety-Critical Applications) without TRINAMIC's specific written consent.

TRINAMIC products are not designed nor intended for use in military or aerospace applications or environments or in automotive applications unless specifically designated for such use by TRINAMIC. TRINAMIC conveys no patent, copyright, mask work right or other trade mark right to this product. TRINAMIC assumes no liability for any patent and/or other trade mark rights of a third party resulting from processing or handling of the product and/or any other use of the product.

12.7 Collateral Documents & Tools

This product documentation is related and/or associated with additional tool kits, firmware and other items, as provided on the product page at: www.trinamic.com.



13 Revision History

13.1 Firmware Revision

Version	Date	Description
V1.01	2016-JUL-20	First release.

Table 315: Firmware Revision

13.2 Document Revision

Version	Date	Description
V1.01	2016-JUL-20	First release.

Table 316: Document Revision

