

WNFQ-258ACN(BT)

802.11ac/a/b/g/n Dual-Band

2T2R Wi-Fi+Bluetooth 4.2 Combo

M.2 Module



WiFi+Bluetooth Combo Solution M.2 Module

Spark LAN WNFQ-258ACN(BT) is an 802.11ac/a/b/g/n Dual-Band Wi-Fi+Bluetooth M.2 card based on Qualcomm Atheros QCA6174A chipset. It was opened to test functionality. It is dual band AC on 2.4 and 5GHz and incorporates the latest Bluetooth 4.2. The slot type is M.2 2230. The download speed are 300Mbps on N networks and 867Mbps on AC network.

Adopting the latest 802.11ac solution. WNFQ-258ACN(BT) is ideal for next-generation high throughput enterprise networking solution. Incorporated with advanced security encryption, such as WEP, WPA, WPA2, WPA3, WPS, and 802.1x, it helps prevent user's devices from malicious attacks.

Embedded Application.

Applications include medical devices, security systems, Point of Sale, digital signs, set-top/net-top box, embedded/ tablet PC's, handheld devices, thin client devices, Gaming machine, notebook computer, etc.

Key Feature.

- Qualcomm Atheros QCA6174A-5
- BT transmission speed including 1M, 2M and 3Mbps EDR operations
- Supports for Simple Pairing(SP) and Enhanced Inquiry Response(EIR) function
- HCI USB interface to work with Windows upper layer stack
- Support MU-MIMO
- Wi-Fi Supports Low Power PCIe (w/L1 substrate) interfaces
- Two-stream spatial multiplexing up to 867Mbps data rate

Specification

Standards	IEEE 802.11ac/a/b/g/n (2T2R) Bluetooth V4.2, V4.1, V4.0 LE, V3.0+HS, V2.1+EDR
Chipset	Qualcomm Atheros QCA6174A-5
Data Rate	802.11b: 11Mbps 802.11a/g: 54Mbps 802.11n: MCS0~15 802.11ac: MCS0~9 Bluetooth: 1Mbps, 2Mbps and up to 3Mbps EDR
Operating Frequency	IEEE 802.11ac/a/b/g/n ISM Band: 2.412GHz~2.484GHz, 5.150GHz~5.850GHz *Subject to local regulations
Interface	WLAN: PCIe Bluetooth: USB
Form Factor	M.2 2230 A-E Key
Antenna	2 x IPEX MHF4 connectors Support WLAN/BT co-existence Main: WLAN, Aux: WLAN/ BT
Modulation	Wi-Fi: 802.11b: DSSS (DBPSK, DQPSK, CCK) 802.11g: OFDM (BPSK, QPSK, 16-QAM, 64-QAM) 802.11n: OFDM (BPSK, QPSK, 16-QAM, 64-QAM) 802.11a: OFDM (BPSK, QPSK, 16-QAM, 64-QAM) 802.11ac: OFDM (BPSK, QPSK, 16-QAM, 64-QAM, 256-QAM) Bluetooth: Header: GFSK Payload 2M: $\pi/4$ -DQPSK Payload 3M: 8-DPSK
Power Consumption	TX mode: 405mA RX mode: 200mA
Operating Voltage	DC 3.3V
Operating Temperature Range	-10°C~70°C

Storage Temperature Range	-40°C~85°C
Humidity (Non-Condensing)	5%~90% (Operating) 5%~90% (Storing)
Dimension L x W x H (in mm)	30mm(±0.15 mm) x 22mm(± 0.15 mm) x 2.15mm(± 0.3mm)
Weight (g)	2.5g
Driver Support	Windows 7/8.1/10/11 Linux (Open Source), Recommend Kernel v4.0+
Security	64/128-bits WEP, WPA, WPA2, WPA3, WPS, 802.1x

OUTPUT POWER & SENSITIVITY

802.11b

Data Rate	Tx \pm 2dBm	Rx Sensitivity
11Mbps	19dBm	\leq -81dBm

802.11g

Data Rate	Tx \pm 2dBm	Rx Sensitivity
54Mbps	16dBm	\leq -66dBm

802.11n / 2.4GHz

HT20	Data Rate	Tx \pm 2dBm (1TX)	Tx \pm 2dBm (2TX)	Rx Sensitivity
	MCS7	16dBm	19dBm	\leq -65dBm
HT40	MCS7	15dBm	18dBm	\leq -61dBm

802.11a

Data Rate	Tx \pm 2dBm	Rx Sensitivity
54Mbps	11dBm	\leq -66dBm

802.11n / 5GHz

HT20	Data Rate	Tx \pm 2dBm (1TX)	Tx \pm 2dBm (2TX)	Rx Sensitivity
	MCS7	9dBm	12dBm	\leq -65dBm
HT40	MCS7	9dBm	12dBm	\leq -61dBm

802.11ac

VHT80	Data Rate	Tx \pm 2dBm (1TX)	Tx \pm 2dBm (2TX)	Rx Sensitivity
	MCS9	7dBm	10dBm	\leq -56dBm

Bluetooth

Data Rate	Tx \pm 2dBm (Class 1 Device)	Rx Sensitivity
3Mbps	$0 \leq$ Output Power \leq 10dBm	<0.1% BR at -70dBm

Block Diagram

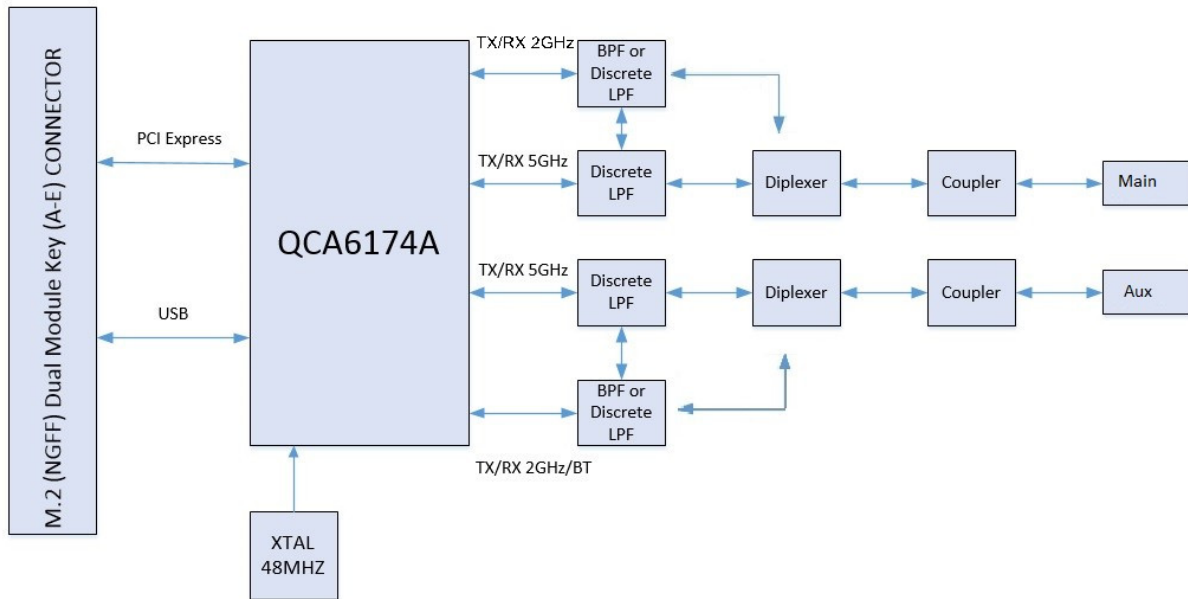

Mechanical Dimension (mm)

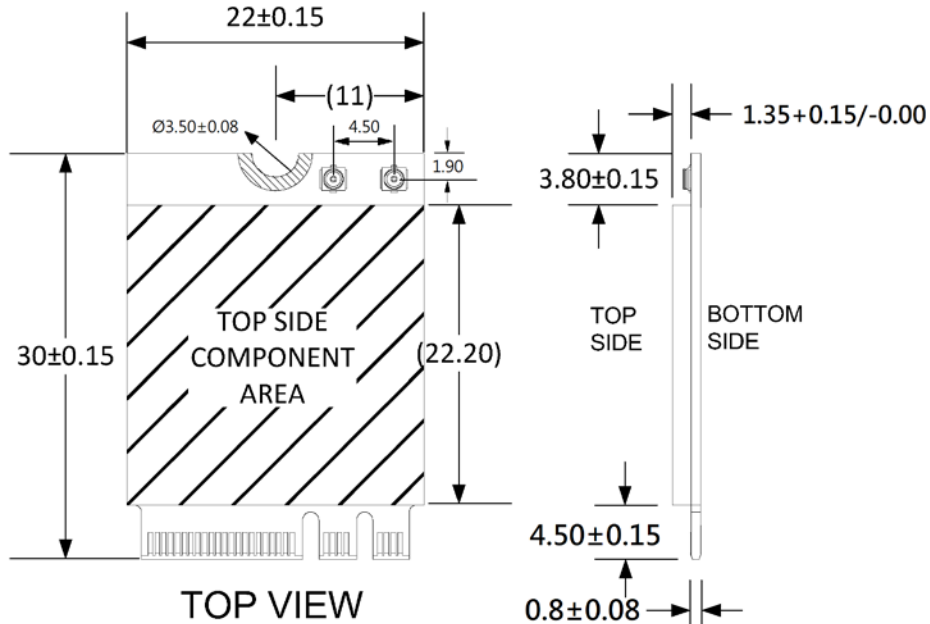

MHF4 Connector spec.

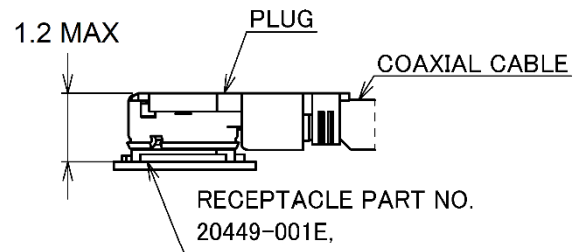
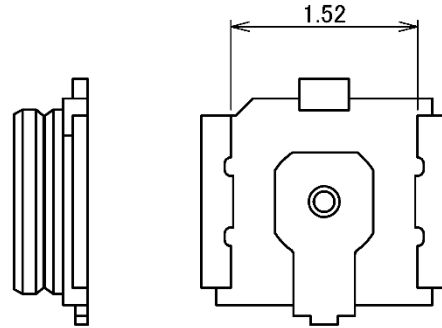
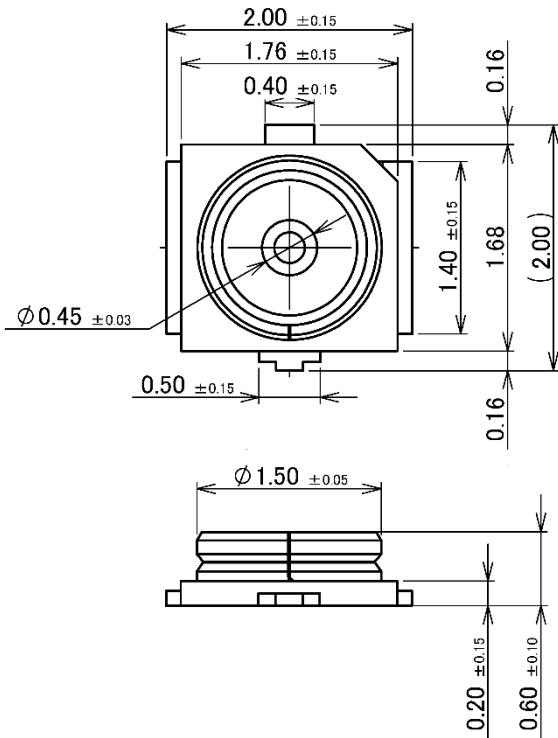

Unit: mm

Pin Assignment

Pin#	Pin Name	Description	Pin#	Pin Name	Description
1	GND	GND	2	+3.3V	+3.3V
3	USB_D+	USB_D+	4	+3.3V	+3.3V
5	USB_D-	USB_D-	6	LED_WLAN_L (OPT)	Defined in the PCI Express Mini card specification and it is an open drain, active low signal, used to allow the PCIe Mini Card add-in card to provide status indicators via LED devices that will be provided by the system.
7	GND	GND	8	No Connection	-
9	No Connection	-	10	No Connection	-
11	No Connection	-	12	No Connection	-
13	No Connection	-	14	No Connection	-
15	No Connection	-	16	BT_LED	Status indicators via LED devices that will be provided by the system and it is an open drain.
17	No Connection	-	18	GND	GND
19	No Connection	-	20	No Connection	-
21	No Connection	-	22	No Connection	-
23	No Connection	-	24	No Connection	-
25	No Connection	-	26	No Connection	-
27	No Connection	-	28	No Connection	-
29	No Connection	-	30	No Connection	-
31	No Connection	-	32	No Connection	-
33	GND	GND	34	No Connection	-
35	PERp0	PCI Express x1 data interface: one differential receive pair	36	No Connection	-
37	PERn0	PCI Express x1 data interface: one differential receive pair	38	Reserved	-
39	GND	GND	40	Reserved	-
41	PETp0	PCI Express x1 data interface: one differential transmit pair	42	Reserved	-
43	PETn0	PCI Express x1 data interface: one differential transmit pair	44	COEX3_ACTIVE	No Connection

Pin Assignment

Pin#	Pin Name	Description	Pin#	Pin Name	Description
45	GND	GND	46	COEX2_PRI	No Connection
47	REFCLK+	Input signal for PCI Express differential reference clock (100 MHz)	48	COEX1_SYNC	No Connection
49	REFCLK-	Input signal for PCI Express differential reference clock (100 MHz)	50	SUSCLK(OPT)	32.768 kHz clock supply input that is provided by PCH to reduce power and cost for the module. SUSCLK will have a duty cycle that can be as low as 30% or as high as 70% 200ppm.
51	GND	GND	52	PERST_L	Input signal for functional reset to the card
53	CLKREQ_L	Output for reference clock request signal	54	BT_DISABLE_L (OPT)	These pins are reserved for definition with future revisions of this specification.
55	WAKE_L (OPT)	Output and open Drain active Low signal. This signal is used to request that the system return from a sleep/suspended state to service a function initiated wake event.	56	W_DISABLE_L (OPT)	Input and active low signal. This signal is used by the system to disable radio operation on add-in cards that implement radio frequency applications. When implemented, this signal requires a pull-up resistor on the card
57	GND	GND	58	No Connection	-
59	Reserved	-	60	No Connection	-
61	Reserved	-	62	No Connection	-
63	GND	GND	64	Reserved	-
65	Reserved	-	66	Reserved	-
67	Reserved	-	68	Reserved	-
69	GND	GND	70	Reserved	-
71	Reserved	-	72	+3.3V	+3.3V
73	Reserved	-	74	+3.3V	+3.3V
75	GND	GND			

*NA→No active, OPT →Optional

Certification

PIFA Ant.

- | | |
|---|--|
| <input checked="" type="checkbox"/> FCC | <input checked="" type="checkbox"/> CE (RED EN 300 328 V2.2.2 / EN 301 893 V2.1.1) |
| <input checked="" type="checkbox"/> IC | <input checked="" type="checkbox"/> MIC |
| <input checked="" type="checkbox"/> NCC | <input checked="" type="checkbox"/> ASNZS |

Dipole Ant.

- | | |
|---|---|
| <input checked="" type="checkbox"/> FCC | <input type="checkbox"/> CE (RED EN 300 328 V2.2.2 / EN 301 893 V2.1.1) |
| <input checked="" type="checkbox"/> IC | <input checked="" type="checkbox"/> MIC |
| <input checked="" type="checkbox"/> NCC | <input type="checkbox"/> ASNZS |

Ordering Information

Product Name	Part Number	Description
WNFQ-258ACN(BT)	R9701810001	802.11ac/b/g/n Wi-Fi + Bluetooth M.2 Card, QCA6174A,2T2R 2230

Optional Accessory

Product Name	Part Number	Description
AD-103AG	R3410110203	2dBi Dipole RP-SMA 5G/2.4GHz
AD-300N	R3410110219	3dBi/5dBi 2.4G/5GHz Dipole RP-SMA
CBIRF-NE150	R3470300025	RF Cable, I-PEXMHF4 to RP-SMA(F); L150mm; Coaxial 0.81 Black
CBIRF-NE250	R3470300026	RF Cable, I-PEXMHF4 to RP-SMA(F); L250mm; Coaxial 0.81 Black