

# ERCW003A6R Power Modules; DC-DC Converters

36 – 75V<sub>dc</sub> Input; 28V<sub>dc</sub> Output; 3.6A<sub>dc</sub> Output

RoHS Compliant

ORCA SERIES™

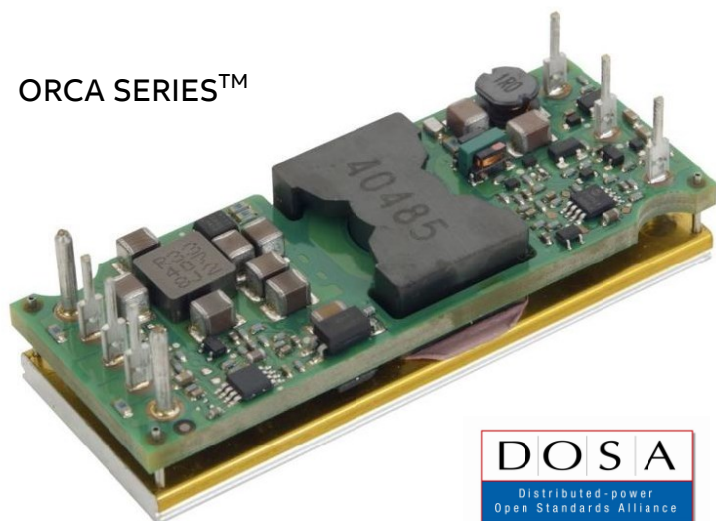

## Description

The ERCW003A6R ORCA™ series of dc-dc converters are a new generation of isolated, very high efficiency DC/DC power modules providing up to up to 3.6A<sub>dc</sub> output current at a nominal output voltage of 28V<sub>dc</sub> in an industry standard, DOSA compliant 1/8 brick size footprint, which makes it an ideal choice for high voltage and high power applications. The ERCW003A6R modules have typical efficiency of 93% at full-load and nominal output voltage of 28V. The maximum output ripple of the module is 20mV<sub>rms</sub>, which helps to reduce external filtering capacitors and system cost. Threaded -through holes are provided to allow easy mounting or addition of a heat sink for high temperature applications. The output is fully

isolated from the input, allowing versatile polarity configurations and grounding connections.

## Applications

- RF Power Amplifier
- Wireless Networks
- Switching Networks

## Options

- Output OCP/OVP auto restart
- Shorter pins
- Unthreaded heatsink holes

---

## Features

- Compliant to RoHS Directive 2011/65/EU and amended Directive (EU) 2015/863.
- Compliant to REACH Directive (EC) No 1907/2006
- High power density: 139W/ in<sup>3</sup>
- Very high efficiency: 93.4% Typ at Full Load (48V<sub>in</sub>, 28V<sub>out</sub>/3.6A)
- Industry standard 1/8 brick pin-out
- Low output ripple and noise
- Supports repetitive loads (AC+DC) up to 2 kHz
- Industry standard, DOSA compliant 1/8 brick footprint 58.4mm x 23.0mm x 8.8mm (2.3" x 0.9" x 0.35")
- Remote Sense
- 2:1 input voltage range
- Single tightly regulated output
- Constant switching frequency
- Output overcurrent and overvoltage protection
- Over temperature protection auto restart
- Output voltage adjustment trim, 15.0V<sub>dc</sub> to 35.2V<sub>dc</sub>
- Wide operating case temperature range (-40°C to 100°C)
- CE mark meets 2014/35/EU directives<sup>5</sup>
- ANSI/UL\* 62368-1 and CAN/CSA<sup>†</sup> C22.2 No. 62368-1 Recognized, DIN VDE<sup>‡</sup> 0868-1/A11:2017 (EN62368-1:2014/A11:2017)
- ISO\*\* 9001 and ISO 14001 certified manufacturing facilities
- Compliant to IPC-9592A, Category 2, Class II

# Technical Specifications

## Absolute Maximum Ratings

Stresses in excess of the absolute maximum ratings can cause permanent damage to the device. These are absolute stress ratings only, functional operation of the device is not implied at these or any other conditions in excess of those given in the operations sections of the data sheet. Exposure to absolute maximum ratings for extended periods can adversely affect the device reliability.

Parameter	Device	Symbol	Min	Max	Unit
Input Voltage					
Continuous	All	$V_{IN}$	-0.3	80	$V_{dc}$
Transient, operational ( $\leq 9$ ms)	All	$V_{IN,trans}$	-0.3	100	$V_{dc}$
Operating Ambient Temperature	All	$T_a$	-40	85	$^{\circ}C$
Operating Case Temperature (See Thermal Considerations section, Figure 17)	All	$T_c$	-40	100	$^{\circ}C$
Storage Temperature	All	$T_{stg}$	-55	125	$^{\circ}C$
I/O Isolation Voltage: Input to Case, Input to Output	All	-	-	2250	$V_{dc}$
Output to Case	All	-	-	500	$V_{dc}$

## Electrical Specifications

Unless otherwise indicated, specifications apply over all operating input voltage, resistive load, and temperature conditions.

Parameter	Device	Symbol	Min	Typ	Max	Unit
Operating Input Voltage (see Figure 12 for $V_{IN,MIN}$ when using trim-up feature)	All	$V_{IN}$	36	48	75	$V_{dc}$
Maximum Input Current ( $V_{IN}=36V$ to $75V$ , $I_o=I_{o,max}$ )	All	$I_{IN,max}$			3.5	$A_{dc}$
Inrush Transient	All	$I^2t$			2	$A^2s$
Input Reflected Ripple Current, peak-to-peak (5Hz to 20MHz, 12 $\mu$ H source impedance; $V_{IN}=0V$ to $75V$ , $I_o=I_{o,max}$ ; see Figure 12)	All				35	$mA_{p-p}$
Input No Load Current $V_{in} = 48V$ , ( $I_o = 0$ , module enabled)	All			70		$mA_{dc}$
Input Stand-by Current ( $V_{in} = 48V$ , module disabled)	All				10	$mA_{dc}$
Input Ripple Rejection (120Hz)	All			50		dB

**CAUTION: This power module is not internally fused. An input line fuse must always be used.**

This power module can be used in a wide variety of applications, ranging from simple standalone operation to being part of complex power architecture. To preserve maximum flexibility, internal fusing is not included; however, to achieve maximum safety and system protection, always use an input line fuse. The safety agencies require a fast-acting fuse with a maximum rating of 10A (see Safety Considerations section). Based on the information provided in this data sheet on inrush energy and maximum dc input current, the same type of fuse with a lower rating can be used. Refer to the fuse manufacturer's data sheet for further information.

# Technical Specifications (continued)

## Electrical Specifications (continued)

Parameter	Device	Symbol	Min	Typ	Max	Unit
Output Voltage Set-point ( $V_{IN}=V_{IN,nom}$ , $I_O=I_{O,max}$ , $T_C=25^\circ C$ )	All	$V_{O,set}$	27.5	28	28.5	$V_{dc}$
Output Voltage Set-Point Total Tolerance (Over all operating input voltage, resistive load, and temperature conditions until end of life)	All	$V_O$	27.0	-	29.0	$V_{dc}$
Output Regulation						
Line ( $V_{IN}=V_{IN,min}$ to $V_{IN,max}$ )	All		-	0.1	0.2	$\%V_{O,set}$
Load ( $I_O=I_{O,min}$ to $I_{O,max}$ )	All		-	0.1	0.2	$\%V_{O,set}$
Temperature ( $T_C = -40^\circ C$ to $+100^\circ C$ )	All		-	0.4	0.75	$\%V_{O,set}$
Output Ripple and Noise on nominal output ( $V_{IN}=V_{IN,nom}$ and $I_O=I_{O,min}$ to $I_{O,max}$ )						
RMS (5Hz to 20MHz bandwidth)	All		-	10	20	$mV_{rms}$
Peak-to-Peak (5Hz to 20MHz bandwidth)	All		-	30	60	$mV_{pk-pk}$
External Capacitance ( $2.5m\Omega < ESR < 80m\Omega$ ) <sup>1</sup>		$C_O$	220	-	1500	$\mu F$
Output Power ( $V_O=28V$ to $35.2V$ )	All	$P_{O,max}$	-	-	100	W
Output Current	All	$I_O$	0		3.6	$A_{dc}$
Output Current Limit Inception (Constant current until $V_O < V_{trimMIN}$ , duration <4s)	All	$I_{O,lim}$	4.0	-	-	$A_{dc}$
Output Short Circuit Current ( $V_O \leq 0.25V_{dc}$ )	All	$I_{O,sc}$			30	$A_{rms}$
Efficiency $V_{IN}=V_{IN,nom}$ , $T_C=25^\circ C$ , $I_O=I_{O,max}$ , $V_O=V_{O,set}$	All	$\eta$	-	93.4	-	%
Switching Frequency		$f_{sw}$	-	280	-	kHz
Dynamic Load Response ( $\Delta I_O/\Delta t=1A/10\mu s$ ; $V_{IN}=V_{IN,nom}$ ; $T_C=25^\circ C$ ; Tested with a 220 $\mu F$ aluminum and a 10 $\mu F$ ceramic capacitor across the load.)						
Load Change from $I_O=25\%-50\%-25\%$ of $I_{O,max}$ : Peak Deviation	All	$V_{pk}$	-	2	-	$\%V_{O,set}$
Settling Time ( $V_O < 10\%$ peak deviation)		$t_s$	-	1.5	-	ms
Load Change from $I_O=50\%-75\%-50\%$ of $I_{O,max}$ : Peak Deviation	All	$V_{pk}$	-	2	-	$\%V_{O,set}$
Settling Time ( $V_O < 10\%$ peak deviation)		$t_s$	-	1.5	-	ms
( $\Delta I_O/\Delta t=10\%I_{O,max}/10ms$ ; $V_{IN}=V_{IN,nom}$ ; $T_C=25^\circ C$ ; Tested with a 470 $\mu F$ aluminum and a 10 $\mu F$ ceramic capacitor across the load, see Figure16.						
Load Change from $I_O=0\%-120\%$ of $I_{O,max}$ : Peak Deviation	All	$V_{pk}$	-	2	-	$\%V_{O,set}$
Settling Time ( $V_O < 10\%$ peak deviation)		$t_s$	-	1.5	-	ms
Load Change from $I_O=120\%$ to $50\%$ of $I_{O,max}$ : Peak Deviation	All	$V_{pk}$	-	2	-	$\%V_{O,set}$
Settling Time ( $V_O < 10\%$ peak deviation)		$t_s$	-	1.5	-	ms

<sup>1</sup>Note: use a minimum 220 $\mu F$  output capacitor. Recommended capacitor is Nichicon CD series, 220 $\mu F/35V$ . If the ambient temperature is less than  $-20^\circ C$ , use more than 3 of recommended minimum capacitors.

## Technical Specifications (continued)

### Isolation Specifications

Parameter	Symbol	Min	Typ	Max	Unit
Isolation Capacitance	$C_{iso}$	-	15	-	nF
Isolation Resistance	$R_{iso}$	10	-	-	M $\Omega$

### General Specifications

Parameter	Device	Symbol	Min	Typ	Max	Unit
Calculated Reliability based upon Telcordia SR-332 Issue 2: Method I Case 3 ( $I_o=80\%I_{o,max}$ , $T_A=40^\circ\text{C}$ , airflow = 200 lfm, 90% confidence)	All	FIT		101.6		10 <sup>9</sup> /Hours
	All	MTBF		9,842,207		Hours
Weight (Open Frame)			-	22.8	-	g
	All			0.81		(oz.)
Weight (with Heatplate)				29.8		g
				1.05		(oz.)

### Feature Specifications

Unless otherwise indicated, specifications apply over all operating input voltage, resistive load, and temperature conditions. See Feature Descriptions for additional information.

Parameter	Device	Symbol	Min	Typ	Max	Unit
Remote On/Off Signal Interface						
$(V_{IN}=V_{IN,min}$ to $V_{IN,max}$ ; open collector or equivalent, Signal referenced to $V_{IN-}$ terminal)						
Negative Logic: device code suffix "1"						
Logic Low = module On, Logic High = module Off						
Positive Logic: No device code suffix required						
Logic Low = module Off, Logic High = module On						
Logic Low - Remote On/Off Current	All	$I_{on/off}$	-	-	1.0	mA
Logic Low - On/Off Voltage	All	$V_{on/off}$	0	-	1.2	$V_{dc}$
Logic High Voltage – (Typ = Open Collector)	All	$V_{on/off}$	2.5		10	$V_{dc}$
Logic High maximum allowable leakage current	All	$I_{on/off}$	-	-	50	$\mu\text{A}$
Turn-On Delay and Rise Times						
$(V_{in}=V_{in,nom}$ , $I_o=I_{o,max}$ , 25C)						
Case 1: $T_{delay}$ = Time until $V_o = 10\%$ of $V_{o,set}$ from application of $V_{in}$ with Remote On/Off set to ON,	All	$T_{delay}$		30		ms
Case 2: $T_{delay}$ = Time until $V_o = 10\%$ of $V_{o,set}$ from application of Remote On/Off from Off to On with $V_{in}$ already applied for at least one second.	All	$T_{delay}$	-	30		ms
$T_{rise}$ = time for $V_o$ to rise from 10% of $V_{o,set}$ to 90% of $V_{o,set}$ .	All	$T_{rise}$	-	50		ms

## Technical Specifications (continued)

### Feature Specifications (continued)

Parameter	Device	Symbol	Min	Typ	Max	Unit
Output Voltage Overshoot ( $I_O=80\%$ of $I_{O,max}$ , $T_A=25^\circ\text{C}$ )					3	% $V_{O,set}$
Output Voltage Adjustment(See Feature Descriptions):						
Output Voltage Remote-sense Range	All	$V_{sense}$			2	% $V_{O,nom}$
Output Voltage Set-point Adjustment Range (trim) Note: see Figure 12	All	$V_{trim}$	15.0	-	35.2	$V_{dc}$
Output Overvoltage Protection	All	$V_{O,limit}$	37	-	42	$V_{dc}$
Over Temperature Protection						
(See Feature Descriptions, Figure 17, open frame version)	All	$T_{ref}$	-	135	-	$^\circ\text{C}$
(See Feature Descriptions, Figure 18, base plate version)			-	120	-	$^\circ\text{C}$
Input Under Voltage Lockout						
Turn-on Threshold	All			35		$V_{dc}$
Turn-off Threshold	All	$V_{IN,UVLO}$	31	32	36	$V_{dc}$
Hysteresis	All			3		$V_{dc}$
Input Over voltage Lockout						
Turn-on Threshold	All			79.5	81	$V_{dc}$
Turn-off Threshold	All	$V_{IN,OVLO}$	81	83	-	$V_{dc}$
Hysteresis	All			3	-	$V_{dc}$

# Technical Specifications (continued)

## Characteristic Curves

The following figures provide typical characteristics for the ERCW003A6A0R (28V, 3.6A) at 25°C. The figures are identical for either positive or negative remote On/Off logic.

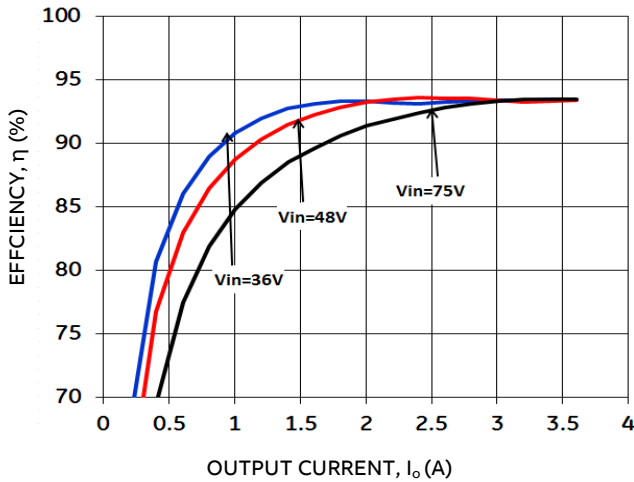

Figure 1. Converter Efficiency versus Output Current.

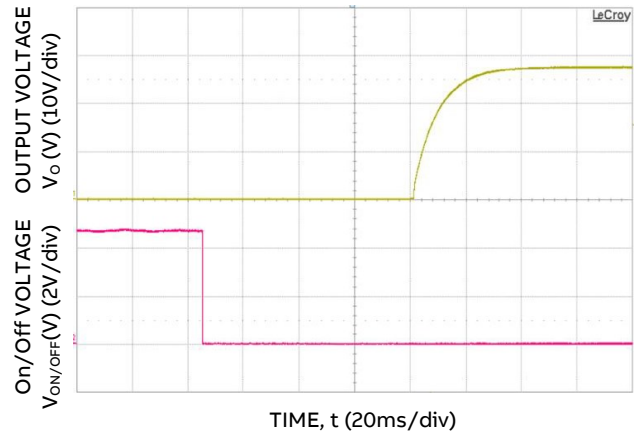

Figure 4. Typical Start-Up Using Remote On/Off;  $C_{o,ext} = 220\mu\text{F}$

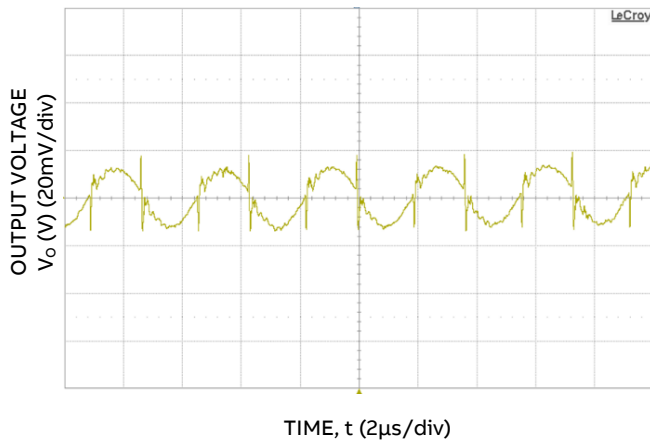

Figure 2. Typical Output Ripple and Noise at Room Temperature and  $48V_{in}$ ,  $I_o = I_{o,max}$ ,  $C_{o,ext} = 220\mu\text{F}$ .

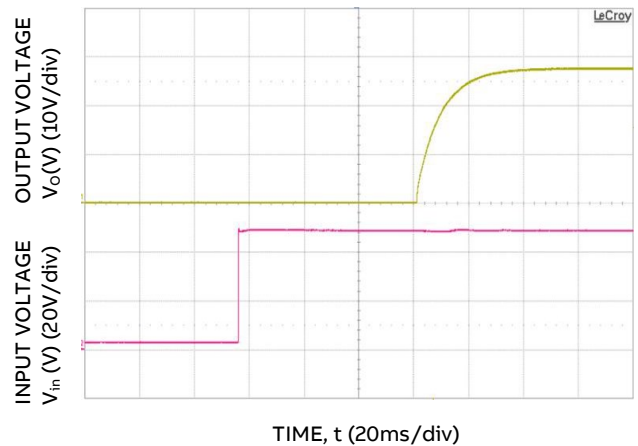

Figure 5. Typical Start-Up from  $V_{in}$ , on/off enabled prior to  $V_{in}$  step;  $C_{o,ext} = 220\mu\text{F}$ .

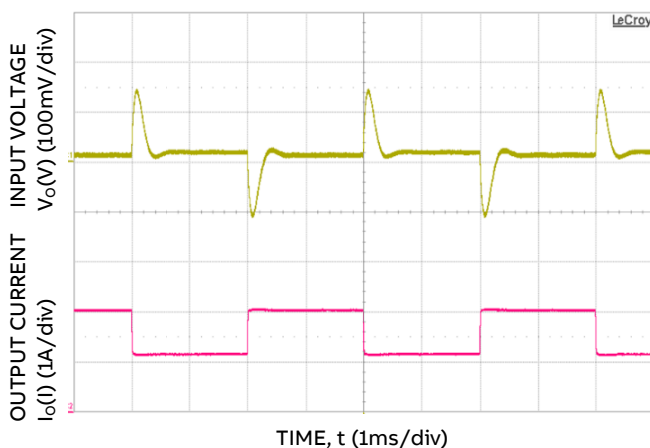

Figure 3. Dynamic Load Change Transient Response from 25% to 50% to 25% of Full Load at Room Temperature and  $48V_{in}$ ,  $0.1\mu\text{s}$ ,  $C_{o,ext} = 220\mu\text{F}$ .

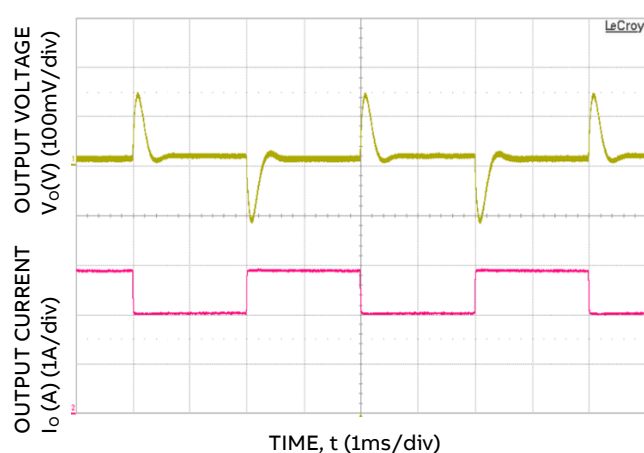

Figure 6. Dynamic Load Change Transient Response from 50% to 75% to 50% of Full Load at Room Temperature and  $48V_{in}$ ;  $0.1\mu\text{s}$ ,  $C_{o,ext} = 220\mu\text{F}$ .

# Technical Specifications (continued)

## Test Configurations

Note: All measurements are taken at the module terminals. When socketing, place Kelvin connections at module terminals to avoid measurement errors due to socket contact resistance.

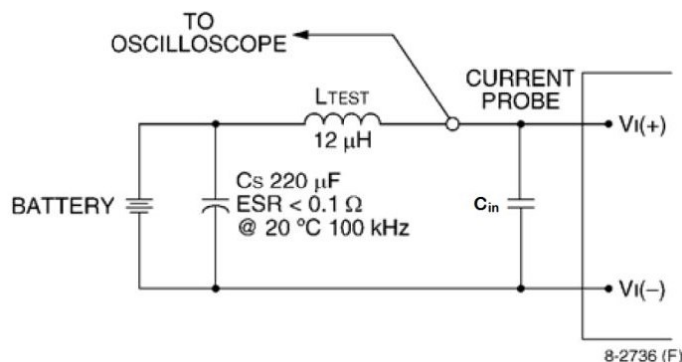

Figure 7. Input Reflected Ripple Current Test Setup.

**NOTE:** Measure input reflected ripple current with a simulated source inductance ( $L_{TEST}$ ) of  $12\mu\text{H}$ . Capacitor  $C_S$  offsets possible battery impedance. Measure current as shown above.

$$\eta = \frac{[V_o(+)-V_o(-)] I_o}{[V_i(+)-V_i(-)] I_i} \times 100 \%$$

## Design Considerations

### Input Source Impedance

The power module should be connected to a low ac -impedance source. A highly inductive source impedance can affect the stability of the power module. For the test configuration in Figure 7, a  $150\mu\text{F}$  Low ESR aluminum capacitor,  $C_{IN}$ , mounted close to the power module helps ensure the stability of the unit. Consult the factory for further application guidelines.

### Output Capacitance

The ERCW003A6R power module requires a minimum output capacitance of  $220\mu\text{F}$  Low ESR aluminum capacitor,  $C_{out}$  to ensure stable operation over the full range of load and line conditions, see Figure 8. If the ambient temperature is under  $-20^\circ\text{C}$ , it is required to use at least 3 pcs of minimum capacitors in parallel. In general, the process of determining the acceptable values of output capacitance and ESR is complex and is load -dependent.

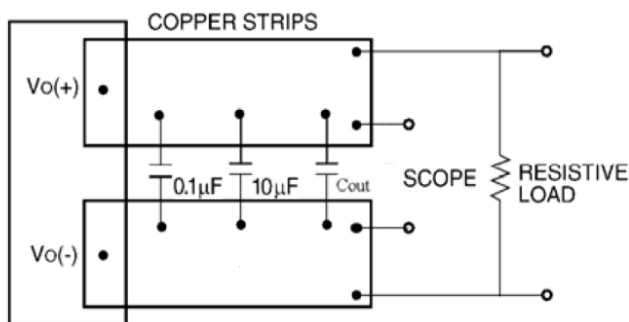

Figure 8. Output Ripple and Noise Test Setup.

**Note:** Use a  $C_{out}$  ( $470\mu\text{F}$  Low ESR aluminum or tantalum capacitor typical), a  $0.1\mu\text{F}$  ceramic capacitor and a  $10\mu\text{F}$  ceramic capacitor, and Scope measurement should be made using a BNC socket. Position the load between 51 mm and 76 mm (2 in. and 3 in.) from the module.

## Safety Considerations

For safety agency approval the power module must be installed in compliance with the spacing and separation requirements of the end-use safety agency standards, i.e., UL ANSI/UL\* 62368-1 and CAN/CSA+ C22.2 No. 62368-1 Recognized, DIN VDE 0868-1/A11:2017 (EN62368-1:2014/A11:2017)

For end products connected to  $-48\text{V}$  dc, or  $-60\text{V}$ dc nominal DC MAINS (i.e. central office dc battery plant), no further fault testing is required. \*Note:  $-60\text{V}$  dc nominal battery plants are not available in the U.S. or Canada.

For all input voltages, other than DC MAINS, where the input voltage is less than  $60\text{V}$  dc, if the input meets all of the requirements for SELV/ES1, then:

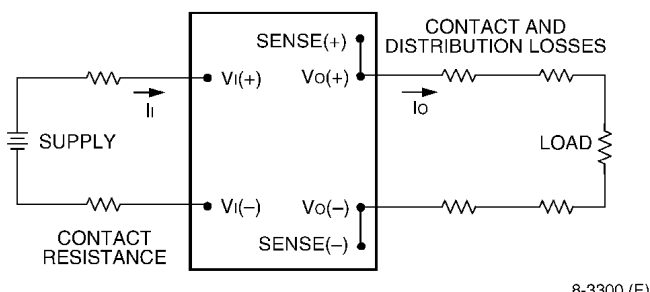

Figure 9. Output Voltage and Efficiency Test Setup.



## Technical Specifications (continued)

### Safety Considerations (continued)

- The output may be considered SELV/ES1. Output voltages will remain within SELV limits even with internally - generated non-SELV voltages. Single component failure and fault tests were performed in the power converters.
- One pole of the input and one pole of the output are to be grounded, or both circuits are to be kept floating, to maintain the output voltage to ground voltage within ELV or SELV/ES1 limits. However, SELV/ES1 will not be maintained if  $V_i(+)$  and  $V_o(+)$  are grounded simultaneously.

If the input source is non-SELV (ELV or a hazardous voltage greater than 60 Vdc and less than or equal to 75V<sub>dc</sub>), for the module's output to be considered as meeting the requirements for safety extra-low voltage (SELV) or ES1, all of the following must be true:

- The input source is to be provided with reinforced insulation from any hazardous voltage, including the acmains.
- One  $V_{IN}$  pin and one  $V_o$  pin are to be reliably earthed, or both the input and output pins are to be kept floating.
- Another SELV or ES1 reliability test is conducted on the whole system (combination of supply source and subject module), as required by the safety agencies, to verify that under a single fault, hazardous voltages do not appear at the module's output.

All flammable materials used in the manufacturing of these modules are rated 94V-0, or tested to the UL60950 A.2 for reduced thickness.

The input to these units is to be provided with a maximum 10A fast-acting or time-delay fuse in the ungrounded input connection.

### Feature Descriptions

#### Remote On/Off

Two remote on/off options are available. Positive logic turns the module on during a logic high voltage on the ON/OFF pin, and off during a logic low. Negative logic remote On/Off, device code suffix "1", turns the module off during a logic high and on during a logic low.

To turn the power module on and off, the user must supply a switch (open collector or equivalent) to control the voltage ( $V_{on/off}$ ) between the ON/OFF terminal and the  $V_{IN}(-)$  terminal (see Figure 10). Logic

low is  $0V \leq V_{on/off} \leq 1.2V$ . The maximum  $I_{on/off}$  during a logic low is 1mA, the switch should be maintain a logic low level whilst sinking this current.

During a logic high, the typical maximum  $V_{on/off}$  generated by the module is 5V, and the maximum allowable leakage current at  $V_{on/off} = 5V$  is 50 $\mu$ A.

If not using the remote on/off feature:

For positive logic, leave the ON/OFF pin open.

For negative logic, short the ON/OFF pin to  $V_{IN}(-)$ .

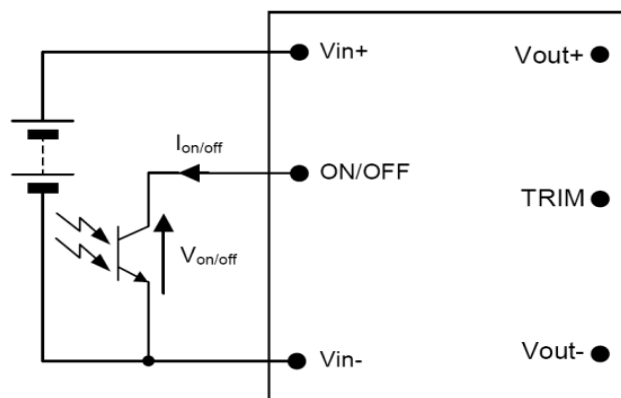

Figure 10. Circuit configuration for using Remote On/Off Implementation.

#### Overcurrent Protection

To provide protection in a fault output overload condition, the module is equipped with internal current limiting protection circuitry, and can endure continuous overcurrent by providing constant current output, for up to 4 seconds, as long as the output voltage is greater than  $V_{trimMIN}$ . If the load resistance is too low to support  $V_{trimMIN}$  in an overcurrent condition or a short circuit load condition exists, the module will shut down immediately.

A auto-restart option is standard. Following shutdown, the module will restart after a period of 3 seconds if the shutdown happens due to overcurrent protection being triggered or the module will restart after a period of 2.5 seconds when the shutdown happens due to output over-voltage protection getting enabled. An latching shutdown option (4) is also available in a case where an auto recovery is required. If overcurrent greater than 4A persists for few milli-seconds, the module will shut down and auto restart until the fault condition is corrected. If the output overload condition still exists when the module restarts, it will shut down again. This operation will continue indefinitely, until the overcurrent condition is corrected.

# Technical Specifications (continued)

## Feature Descriptions (continued)

### Over Voltage Protection

The output overvoltage protection consists of circuitry that monitors the voltage on the output terminals. If the voltage on the output terminals exceeds the over voltage protection threshold, then the module will shutdown and latch off. The overvoltage latch is reset by either cycling the input power for one second or by toggling the on/off signal for one second. The protection mechanism is such that the unit can continue in this condition until the fault is cleared.

An auto-restart option (4) is also available in a case where an auto recovery is required.

### Remote sense

Remote sense minimizes the effects of distribution losses by regulating the voltage at the remote-sense connections (see Figure 11). For No Trim or Trim down application, the voltage between the remote-sense pins and the output terminals must not exceed the output voltage sense range given in the Feature Specifications table i.e.:

$$[V_o(+)-V_o(-)] - [\text{SENSE}(+) - \text{SENSE}(-)] \leq 2\% \text{ of } V_{o,nom}$$

The voltage between the  $V_o(+)$  and  $V_o(-)$  terminals must not exceed the minimum output overvoltage shut-down value indicated in the Feature Specifications table. This limit includes any increase in voltage due to remote-sense compensation and output voltage set-point adjustment (trim). See Figure 11. If not using the remote-sense feature to regulate the output at the point of load, then connect SENSE(+) to  $V_o(+)$  and SENSE(-) to  $V_o(-)$  at the module.

Although the output voltage can be increased by both the remote sense and by the trim, the maximum increase for the output voltage is not the sum of both. The maximum increase is the larger of either the remote sense or the trim. The amount of power delivered by the module is defined as the voltage at the output terminals multiplied by the output current. When using remote sense and trim: the output voltage of the module can be increased, which at the same output current would increase the power output of the module. Care should be taken to ensure that the maximum output power of the module remains at or below the maximum rated power.

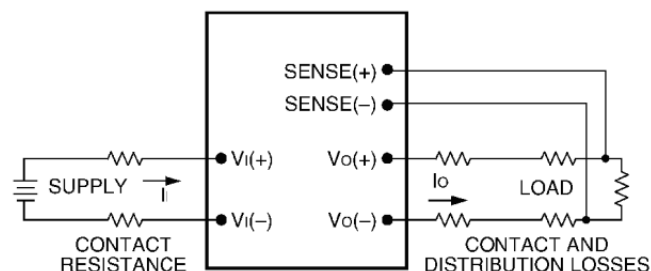

Figure 11. Effective Circuit Configuration for Single-Module Remote-Sense Operation Output Voltage.

### Output Voltage Programming

Trimming allows the user to increase or decrease the output voltage set point of a module. Trimming down is accomplished by connecting an external resistor between the TRIM pin and the SENSE(-) pin. Trimming up is accomplished by connecting external resistor between the SENSE(+) pin and TRIM pin. The trim resistor should be positioned close to the module. Certain restrictions apply to the input voltage lower limit when trimming the output voltage to the maximum. See Figure 12 for the allowed input to output range when using trim. If not using the trim down feature, leave the TRIM pin open.

### Trim Down – Decrease Output Voltage

With an external resistor ( $R_{adj\_down}$ ) between the TRIM and SENSE (-) pins, the output voltage set point ( $V_{o,adj}$ ) decreases (see Figure 13). The following equation determines the required external-resistor value to obtain a percentage output voltage change of  $\Delta\%$ .

$$R_{adj\_down} = \left[ \frac{511}{\Delta\%} - 10.22 \right] \text{ k}\Omega$$

Where

$$\Delta\% = \left( \frac{V_{Oset} - V_{Odesired}}{V_{Oset}} \right) \times 100$$

# Technical Specifications (continued)

## Feature Descriptions (continued)

### Trim Down – Decrease Output Voltage (continued)

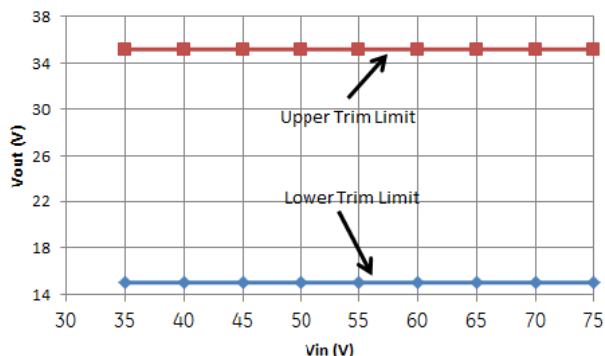

Figure 12. Output Voltage Trim Limits vs. Input Voltage.

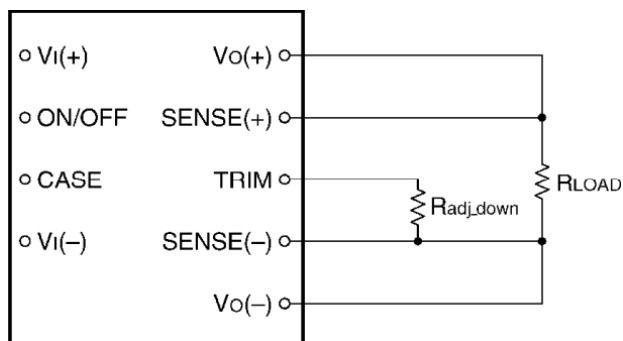

Figure 13. Circuit Configuration to Decrease Output Voltage.

### Trim Up – Increase Output Voltage

With an external resistor ( $R_{adj\_up}$ ) connected between the SENSE(+) and TRIM pins, the output voltage set point ( $V_{o,adj}$ ) increases (see Figure 14).

The following equation determines the required external-resistor value to obtain a percentage output voltage change of  $\Delta\%$ .

$$R_{trim-down} = \left[ \frac{511 \times V_{Oset} \times (100 + \Delta\%)}{1.225 \times \Delta\%} - \frac{511}{\Delta\%} - 10.22 \right] \text{ k}\Omega$$

Where

$$\Delta\% = \left( \frac{V_{Odesired} - V_{Oset}}{V_{Oset}} \right) \times 100$$

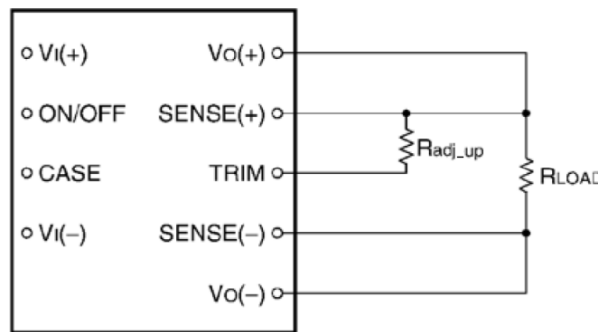

Figure 14. Circuit Configuration to Increase Output Voltage.

The voltage between the  $V_o(+)$  and  $V_o(-)$  terminals must not exceed the minimum output overvoltage shut-down value indicated in the Feature Specifications table. This limit includes any increase in voltage due to remote-sense compensation and output voltage set-point adjustment (trim). See Figure 11.

Although the output voltage can be increased by both the remote sense and by the trim, the maximum increase for the output voltage is not the sum of both. The maximum increase is the larger of either the remote sense or the trim. The amount of power delivered by the module is defined as the voltage at the output terminals multiplied by the output current. When using remote sense and trim, the output voltage of the module can be increased, which the same output current would increase the power output of the module.

Care should be taken to ensure that the maximum output power of the module remains at or below the maximum rated power.

### Examples:

To trim down the output of a nominal 28V module to 16.8V

$$\Delta\% = \left| \frac{28 - 16.8}{28} \right| \times 100 = 40\%$$

$$R_{adj\_down} = \left[ \frac{511}{40} - 10.22 \right] = 2.56 \text{ k}\Omega$$

To trim up the output of a nominal 28V module to 32.0V

## Technical Specifications (continued)

### Output Voltage Programming (continued)

$$\Delta\% = \left| \frac{32.0 - 28}{28} \right| \times 100 = 14.3\%$$

$$R_{\text{adj-up}} = \left[ \frac{5.11 \times 28 \times (100 + 14.3)}{1.225 \times 14.3} - \frac{(511)}{14.3} - 10.22 \right] \text{ k}\Omega$$

$$R_{\text{adj-up}} = 887 \text{ k}\Omega$$

### Active Voltage Programming

For ERCW003A6Rx, a Digital-Analog converter (DAC), capable of both sourcing and sinking current, can be used to actively set the output voltage, as shown in Figure 15. The value of  $R_G$  will be dependent on the voltage step and range of the DAC and the desired values for trim-up and trim-down  $\Delta\%$ . Please contact your ABB Power technical representative to obtain more details on the selection for this resistor.

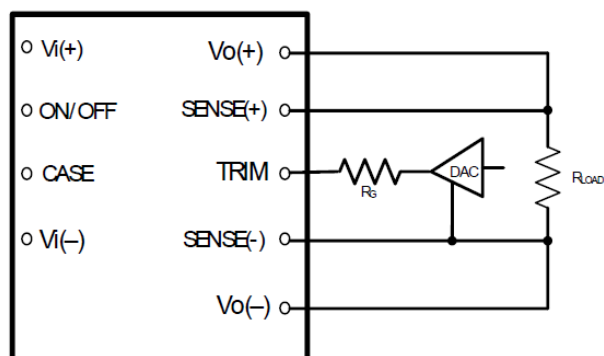

Figure 15. Circuit Configuration to Actively Adjust the Output Voltage.

### AC+DC Load Capability

The ERCW003A6Rx is compatible with load profiles as shown in Figure 16.

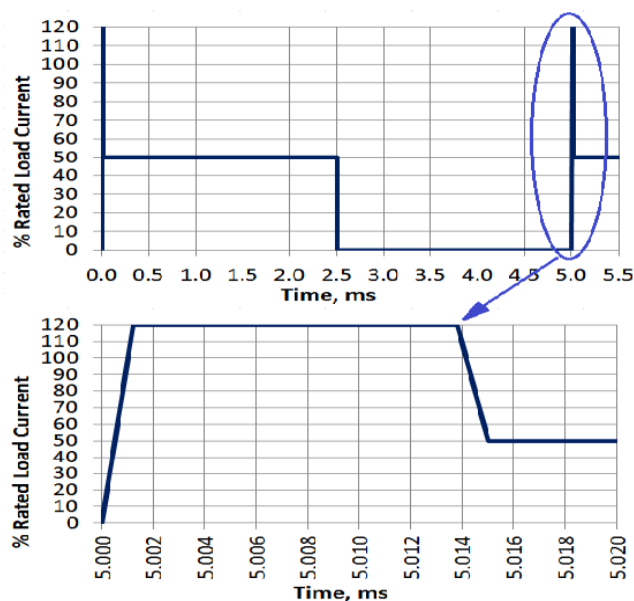

Figure 16. AC-DC Load Profile

The output voltage peak deviation shall not exceed the peak values listed in the Electrical Specifications Table.

### Over Temperature Protection

The ERCW003A6R module provides a non-latching over temperature protection. A temperature sensor monitors the operating temperature of the converter. If the reference temperature,  $T_{REF1}$ , exceeds a threshold of 135°C (typical) for open frame version, and 120°C for base plate version. The converter will shut down and disable the output. When the base plate temperature has decreased by approximately 20°C the converter will automatically restart.

### Thermal Considerations

The power modules operate in a variety of thermal environments; however, sufficient cooling should be provided to help ensure reliable operation of the unit. Heat-dissipating components inside the unit are thermally coupled to the case. Heat is removed by conduction, convection, and radiation to the surrounding environment. Proper cooling can be verified by measuring the case temperature. Peak temperature ( $T_{REF}$ ) occurs at the position indicated in Figure 17 and 18.

Considerations include ambient temperature, airflow, module power dissipation, and the need for increased reliability. A reduction in the operating

# Technical Specifications (continued)

## Thermal Consideration (continued)

temperature of the module will result in an increase in reliability. The thermal data presented here is based on physical measurements taken in a wind tunnel.

The output power of the module should not exceed the rated power for the module as listed in the ordering Information table. Although the maximum TREF temperature of the power modules is discussed above, you can limit this temperature to a lower value for extremely high reliability.

The thermal reference points,  $T_{ref}$ , used in the specifications for open frame module is shown in Figure 17. For reliable operation, the temperatures should not exceed 122°C.

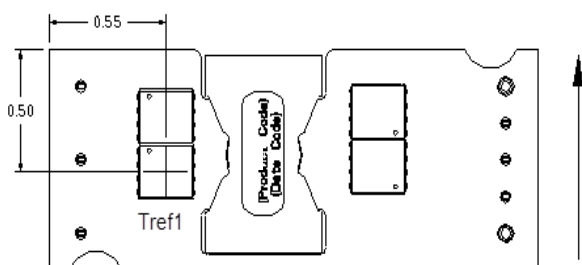

Figure 17. Case ( $T_{REF}$ ) Temperature Measurement Location (top view).

The thermal reference points,  $T_{ref}$ , used in the specifications for base plate module is shown in Figure 18. For reliable operation, the temperature should not exceed 113°C.



Figure 18. Case ( $T_{REF}$ ) Temperature Measurement Location (top view).

## Thermal Derating

Thermal derating is presented for two different applications: 1) Figure 19 and 20, the ERCW003A6R module is thermally coupled to a cold plate inside a sealed clamshell chassis, without any internal air circulation; and 2) Figure 21, the ERCW003A6R module is mounted in a traditional open chassis or cards with forced air flow. In application 1, the module is cooled entirely by conduction of heat from the module primarily through the top surface to a cold plate, with some conduction through the module's pins to the power layers in the system board and can deliver full load up to 100°C. For application 2, the module is cooled by heat removal into a forced airflow that passes through the interior of the module and over the top base plate and/or attached heatsink. Figure 22 shows thermal derating curves for ERCW003A6R module with baseplate attached.

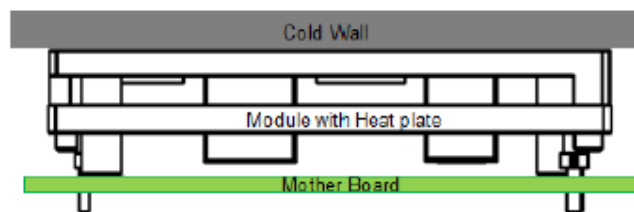

Figure 19. Cold Wall Mounting

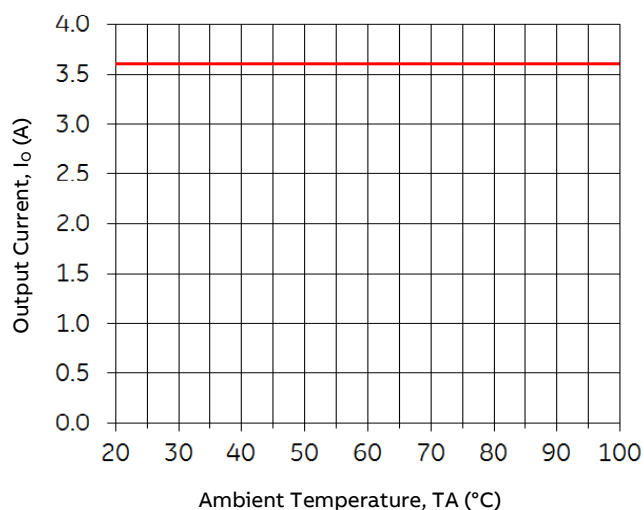

Figure 20. Derating Output Current vs. Cold Wall Temperature with local ambient temperature around module at 85°C;  $V_{in} = 48V$

# Technical Specifications (continued)

## Thermal Consideration (continued)

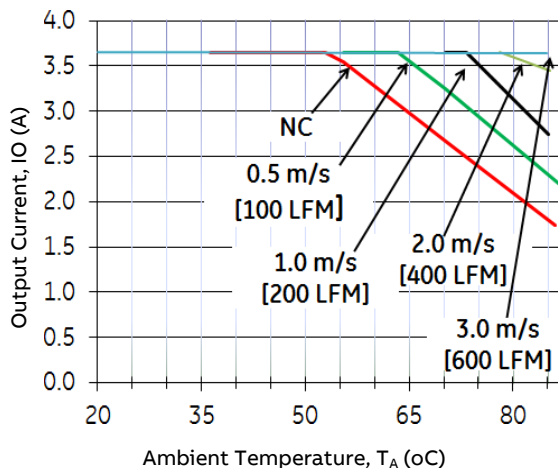

Figure 21. Derating Output Current vs. local Ambient temperature and Airflow, open frame or No baseplate,  $V_{in}=48V$ , airflow from  $V_i(-)$  to  $V_i(+)$ .

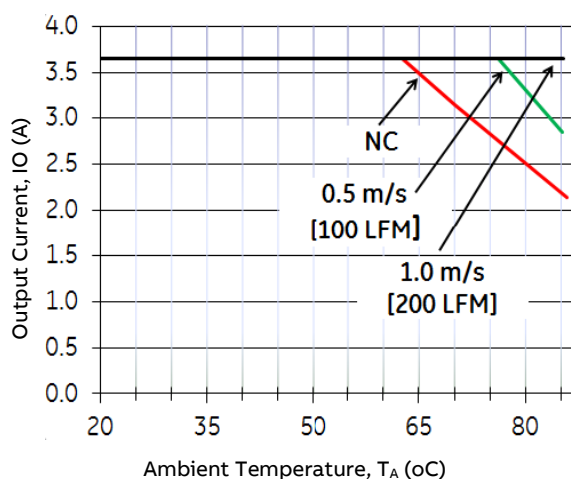

Figure 22. Derating Output Current vs. local Ambient temperature and Airflow, with Baseplate,  $V_{in}=48V$ , airflow from  $V_i(-)$  to  $V_i(+)$ .

testability of the finished circuit-board assembly. For guidance on appropriate soldering, cleaning and drying procedures, refer to ABB Power Board Mounted Power Modules: Soldering and Cleaning Application Note.

## Through-Hole Lead-Free Soldering Information

The RoHS-compliant through-hole products use the SAC (Sn/Ag/Cu) Pb-free solder and RoHS-compliant components. They are designed to be processed through single or dual wave soldering machines. The pins have an RoHS-compliant finish that is compatible with both Pb and Pb-free wave soldering processes. A maximum preheat rate of 3°C/s is suggested. The wave preheat process should be such that the temperature of the power module board is kept below 210°C. For Pb solder, the recommended pot temperature is 260°C, while the Pb-free solder pot is 270°C max. The ERCW003A6R can be processed with paste-through-hole Pb or Pb-free reflow process. If additional information is needed, please consult with your ABB Power representative for more details.

## Layout Considerations

The ERCW003A6R power module series are constructed using a single PWB with integral base plate; as such, component clearance between the bottom of the power module and the mounting (Host) board is limited. Avoid placing copper areas on the outer layer directly underneath the power module.

## Post Solder Cleaning and Drying Considerations

Post solder cleaning is usually the final circuit-board assembly process prior to electrical board testing. The result of inadequate cleaning and drying can affect both the reliability of a power module and the



# Technical Specifications (continued)

## Packaging Details

All versions of the ERCW003A6R are supplied as standard in the plastic trays shown in Figure 23. Each tray contains a total of 18 power modules. The trays are self-stacking and each shipping box for the ERCW003A6R module contains 2 full trays plus one empty hold-down tray giving a total number of 36 power modules.

### Tray Specification

Material	PET (1mm)
Max surface resistivity	$10^9 - 10^{11} \Omega/\text{PET}$
Color	Clear
Capacity	18 power modules
Min order quantity	36 pcs (1 box of 2 full trays + 1 empty top tray)

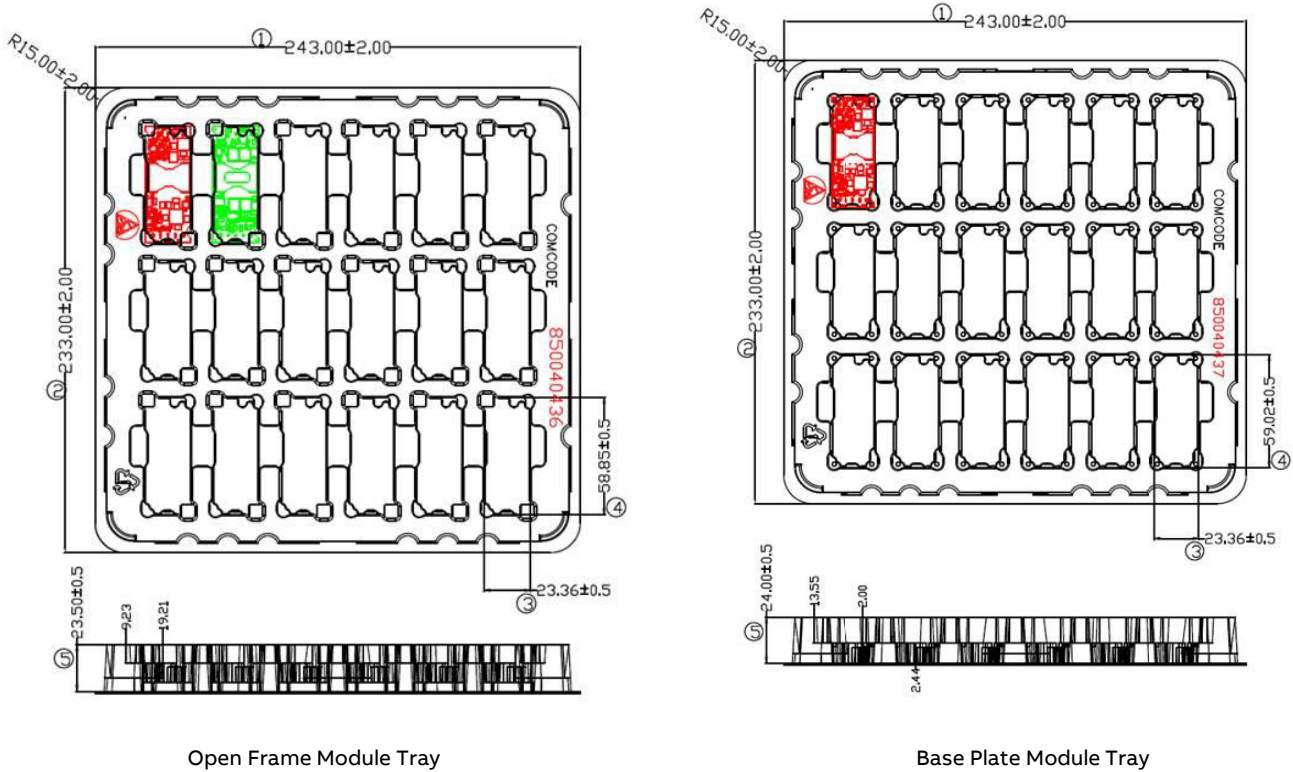

Figure 25. ERCW003A6R Packaging Tray

# Technical Specifications (continued)

## Mechanical Outline for Through-hole Module

Dimensions are in millimeters and [inches].

Tolerances: x.x mm ±0.5 mm [x.xx in. ± 0.02 in.] (Unless otherwise indicated)

x.xx mm ± 0.25 mm [x.xxx in ± 0.010 in.]

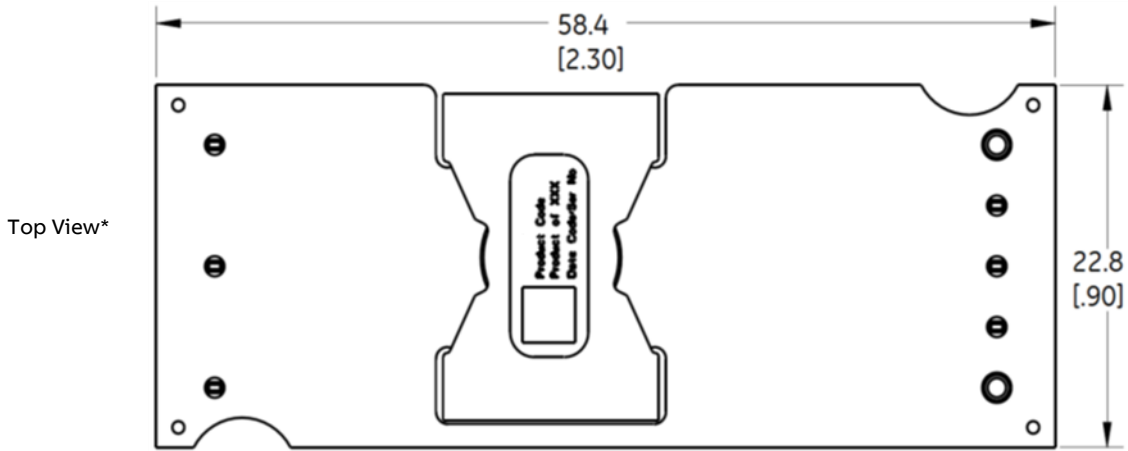

\*Top side label includes ABB name, product designation and date code.

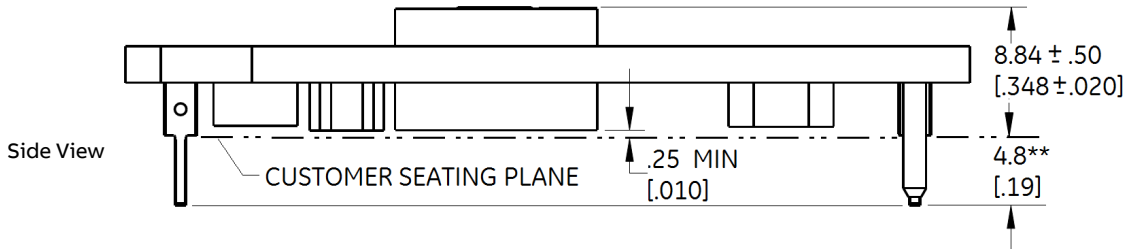

\*\*For optional pin lengths, see Table 2, Device Coding Scheme and Options

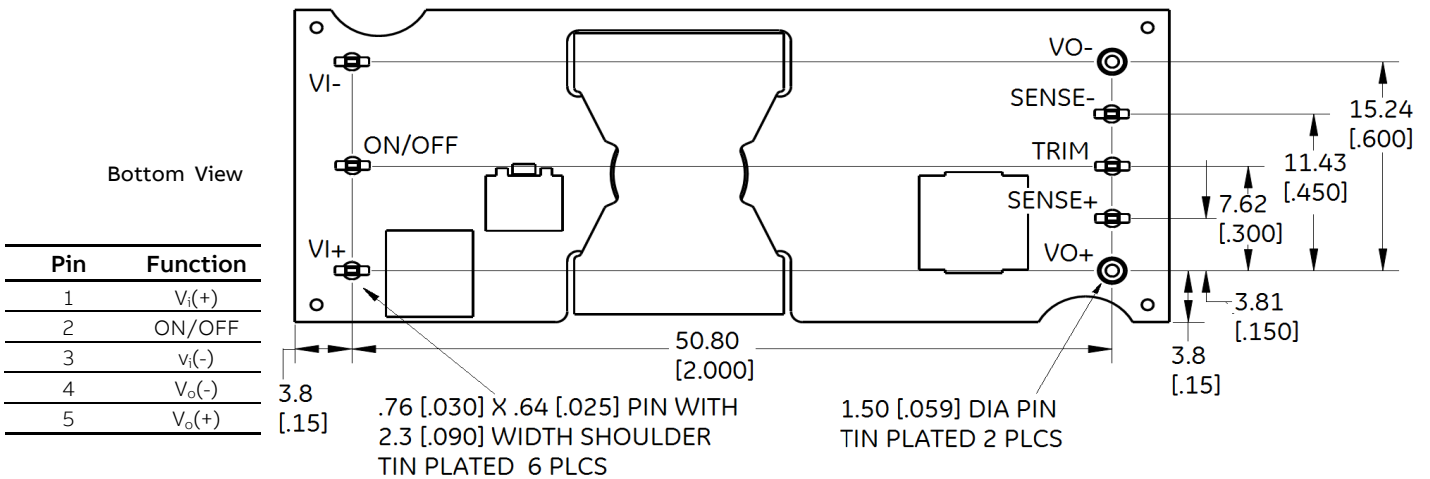

Pin	Function
1	$V_i(+)$
2	ON/OFF
3	$v_i(-)$
4	$V_o(-)$
5	$V_o(+)$



# Technical Specifications (continued)

## Mechanical Outline for Through-Hole Module with Heat Plate (-H Option)

Dimensions are in millimeters and [inches].

Tolerances: x.x mm ± 0.5 mm [x.xx in. ± 0.02 in.] (Unless otherwise indicated)

x.xx mm ± 0.25 mm [x.xxx in ± 0.010 in.]

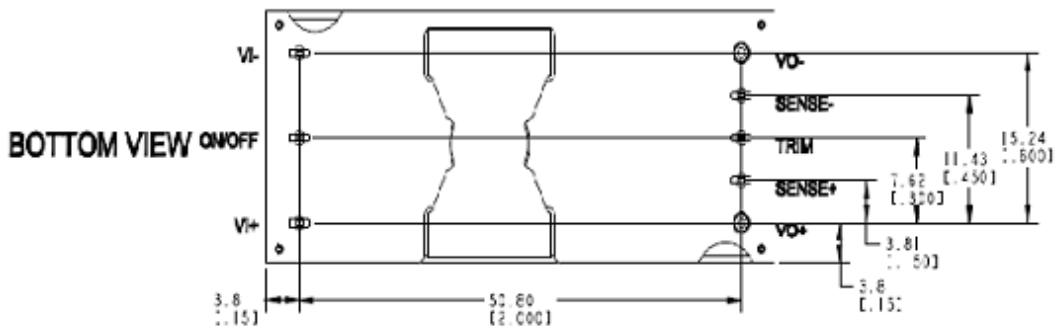
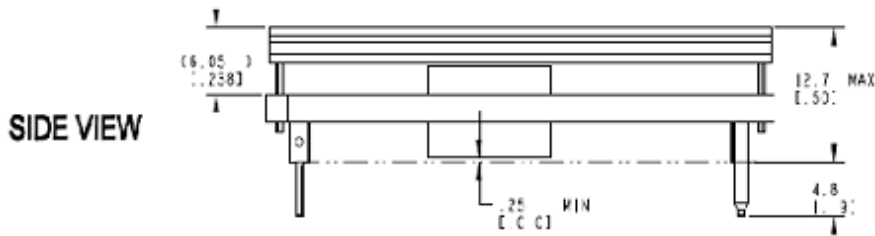
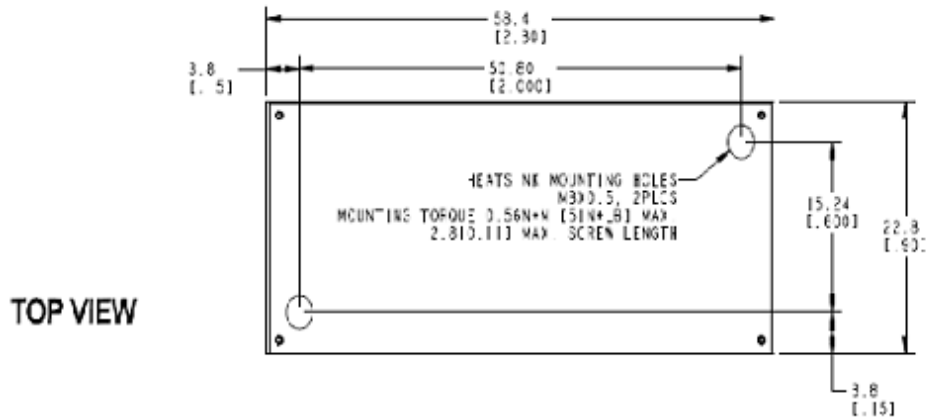

Pin	Function
1	V <sub>i</sub> (+)
2	ON/OFF
3	V <sub>i</sub> (-)
4	V <sub>o</sub> (-)
5	SENSE(-)
6	TRIM
7	SENSE(+)
8	V <sub>o</sub> (+)

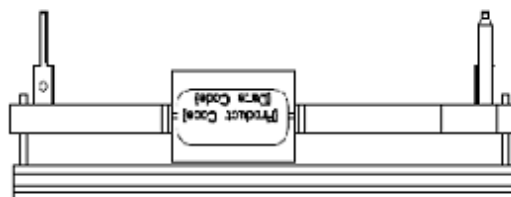

# Technical Specifications (continued)

## Mechanical Outline for Through-Hole Module with 1/4 Brick Heat Plate (-18H Option)

Dimensions are in millimeters and [inches].

Tolerances: x.x mm ± 0.5 mm [x.xx in. ± 0.02 in.] (Unless otherwise indicated)

x.xx mm ± 0.25 mm [x.xxx in. ± 0.010 in.]

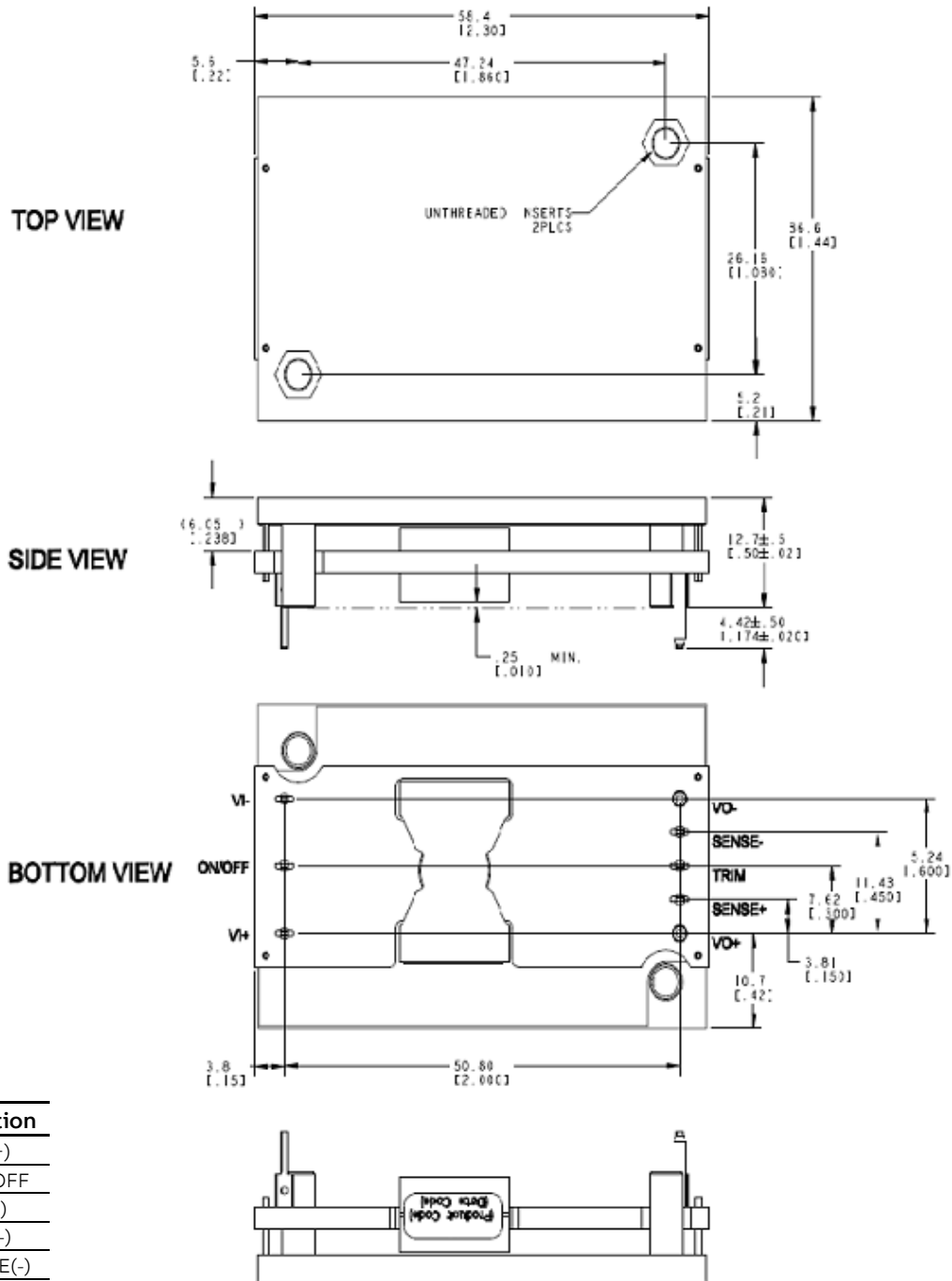

Pin	Function
1	Vi(+)
2	ON/OFF
3	vi(-)
4	Vo(-)
5	SENSE(-)
6	TRIM
7	SENSE(+)
8	Vo(+)

# Technical Specifications (continued)

## Recommended Pad Layout

Dimensions are in millimeters and [inches].

Tolerances: x.x mm ± 0.5 mm [x.xx in. ± 0.02 in.] (Unless otherwise indicated)

x.xx mm ± 0.25 mm [x.xxx in ± 0.010 in.]

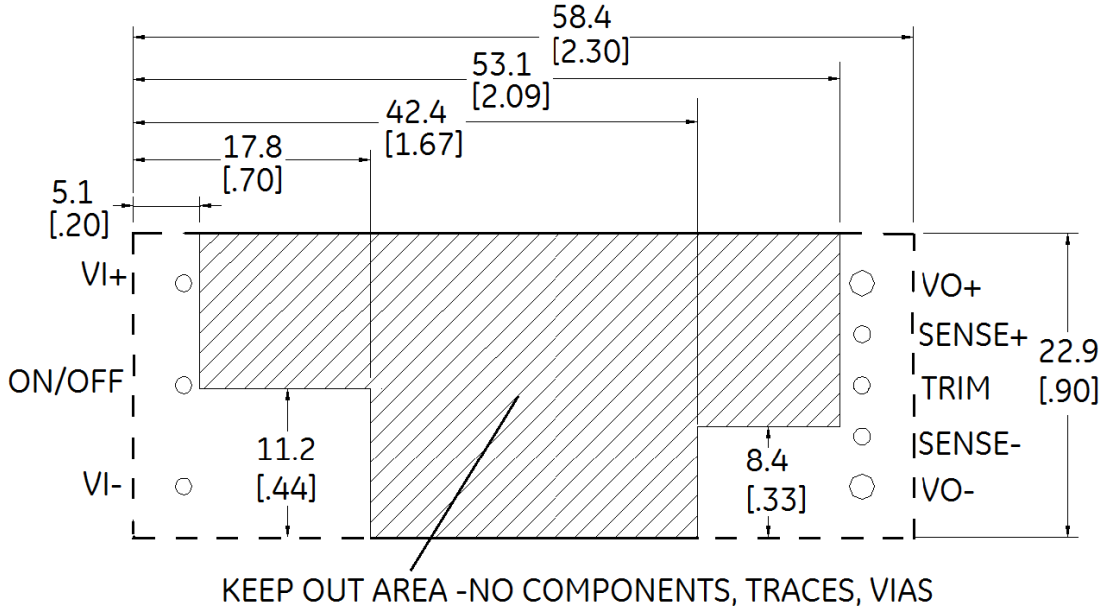

Pin	Function
1	V <sub>i</sub> (+)
2	ON/OFF
3	v <sub>i</sub> (-)
4	V <sub>o</sub> (-)
5	SENSE(-)
6	TRIM
7	SENSE(+)
8	V <sub>o</sub> (+)

Hole and Pad diameter recommendations:

Pin Number	Hole Dia mm [in]	Pad Dia mm [in]
1, 2, 3, 5, 6, 7	1.6 [.063]	2.1 [.083]
4, 8	2.2 [.087]	3.2 [.126]

## Technical Specifications (continued)

### Ordering Information

Please contact your ABB Sales Representative for pricing, availability and optional features.

Input Voltage	Output Voltage	Output Current	Efficiency	Connector Type	MSL Rating	Product codes	Ordering Code
48V (36-75Vdc)	28V	3.6A	93%	Through hole	2a	ERCW003A6R41Z	150037559
48V (36-75Vdc)	28V	3.6A	93%	Through hole	2a	ERCW003A6R41-HZ	150037560

Table 1. Device Codes

Characteristic	Character and Position	Definition
Ratings	Form Factor E	E = Eight Brick
	Family Designator RC	RC = Orca™ Series
	Input Voltage W	W = Wide Range, 36-75V
	Output Current 003A6	003A6 = 3.6 Amps Maximum Output Current(@15-28 Vout)
	Output Voltage R	R=28.0V nominal
Pin Length	6	Omit = Default Pin Length shown in Mechanical Outline Figures 6 = Pin Length: 3.68 mm ± 0.25mm , (0.145 in. ± 0.010 in.)
	8	8 = Pin Length: 2.79 mm ± 0.25mm , (0.110 in. ± 0.010 in.)
Options	Action following Protective Shutdown 4	Omit = Latching Mode 4 = Auto restart following shutdown (overcurrent/overvoltage)
	On/Off Logic 1	Omit = Positive Logic 1 = Negative Logic
	Customer Specific XY	XY= Customer Specific Modified Code, Omit for Standard Code
	Mechanical Features	H
18H		1/4 Brick size heat plate with unthreaded inserts for use in coldwall application (not available with—S option)
RoHS		Omit = RoHS 5/6, Lead Based Solder Used Z Z = RoHS Compliant

Table 2. Device Options

### Contact Us

For more information, call us at

1-877-546-3243 (US)

1-972-244-9288 (Int'l)

## Change History (excludes grammar & clarifications)

Version	Date	Description of the change
1.3	04/27/2022	Updated as per template , ROHS



---

**ABB**

601 Shiloh Rd.  
Plano, TX USA

[abbpowerconversion.com](http://abbpowerconversion.com)

We reserve the right to make technical changes or modify the contents of this document without prior notice. With regard to purchase orders, the agreed particulars shall prevail. ABB does not accept any responsibility whatsoever for potential errors or possible lack of information in this document.

We reserve all rights in this document and in the subject matter and illustrations contained therein. Any reproduction, disclosure to third parties or utilization of its contents – in whole or in parts – is forbidden without prior consent of ABB

Copyright© 2021 ABB

All rights reserved