



**P-DUKE**  
**POWER**

**RCD10U** Series

DC-DC Converter  
Up to 10 Watts

**3**  
YEARS  
WARRANTY

ROHS  
COMPLIANT

REACH  
COMPLIANT



Railway



Automation



Datacom



IPC



Industry



Measurement



Telecom



Automobile



Boat



Charger



Medical



PV



**3000**  
VDC  
Isolation  
Voltage

**12:1**  
Ultra-Wide  
Input  
Range

**6**  
sided  
Shielding

**HOLD**  
**UP**

**LOW**  
Standby  
Power

**NO**  
Min. Load  
Required

**REMOTE**  
**ON**  
**OFF**

**UVP**  
Adjustable

**OCP**

**OVP**

**SCP**

**UVP**

**OTP**

**PART NUMBER STRUCTURE**

Series Name	Input Voltage (VDC)	Output Quantity	Output Voltage (VDC)	Input Range	Remote ON/OFF & Trim Options	Bus & UVP adj. Options	Assembly Options
RCD10 -	<b>36</b>	<b>S</b>	<b>05</b>	<b>U</b>	<b>A</b>	<b>K</b>	<b>HC1</b>
	36:9-75 72:14-160	S:Single	3P3:3.3 5:5 5P1:5.1 12:12 15:15 24:24	8:1 12:1	<input type="checkbox"/> :Negative logic A:Positive logic	<input type="checkbox"/> : None K: With Bus. V: With UVP adj.	<input type="checkbox"/> : None HC1: 7GA0117P01-F ;H=0.3" HC2: 7GA0118P01-F ;H=0.5" HC3: 7GA0119P01-F ;H=0.8"
		D: Dual	5:±5 12:±12 15:±15				

**TECHNICAL SPECIFICATION** All specifications are typical at nominal input, full load and 25°C unless otherwise noted

Model Number	Input Range	Output Voltage	Output Current @Full Load	Input Current @No Load	Efficiency	Maximum Capacitor Load
	VDC	VDC	mA	mA	%	µF
RCD10-36S3P3U	9 ~ 75	3.3	3000	10	85	3500
RCD10-36S05U	9 ~ 75	5	2000	10	86	2500
RCD10-36S5P1U	9 ~ 75	5.1	2000	10	86	2500
RCD10-36S12U	9 ~ 75	12	830	10	88	430
RCD10-36S15U	9 ~ 75	15	670	10	88	350
RCD10-36S24U	9 ~ 75	24	420	10	88	125
RCD10-36D05U	9 ~ 75	±5	±1000	10	83	±1440
RCD10-36D12U	9 ~ 75	±12	±416	10	87	±250
RCD10-36D15U	9 ~ 75	±15	±333	10	87	±180
RCD10-72S3P3U	14 ~ 160	3.3	3000	6	86	3500
RCD10-72S05U	14 ~ 160	5	2000	6	88	2500
RCD10-72S5P1U	14 ~ 160	5.1	2000	6	88	2500
RCD10-72S12U	14 ~ 160	12	830	6	88	430
RCD10-72S15U	14 ~ 160	15	670	6	89	350
RCD10-72S24U	14 ~ 160	24	420	6	87	125
RCD10-72D05U	14 ~ 160	±5	±1000	6	84	±1440
RCD10-72D12U	14 ~ 160	±12	±416	6	87	±250
RCD10-72D15U	14 ~ 160	±15	±333	6	88	±180

**INPUT SPECIFICATIONS**

Parameter	Conditions	Min.	Typ.	Max.	Unit
Operating input voltage range	36Vin(nom)	9	36	75	VDC
	72Vin(nom)	14	72	160	
Start up voltage	36Vin(nom)			9	VDC
	72Vin(nom)			14	
Shutdown voltage	36Vin(nom)	7.3	7.7	8.1	VDC
	72Vin(nom)	10	11	12	
Start up time	Constant resistive load Power up Remote ON/OFF		30 30	40 40	ms
Input Transient voltage	1 second, max. 36Vin(nom) 72Vin(nom)	8.1 12			VDC
Input surge voltage	1 second, max. 36Vin(nom) 72Vin(nom)			100 200	VDC
Input filter				Pi type	
Remote ON/OFF	Referred to -Vin pin Positive logic (Option) Negative logic (Standard) Input current of Ctrl pin Remote off input current		DC-DC ON DC-DC OFF DC-DC ON DC-DC OFF	Open or 3 ~ 15VDC Short or 0 ~ 1.2VDC Open or 3 ~ 15VDC	-0.5 1.5 +1.0 mA mA

OUTPUT SPECIFICATIONS							
Parameter	Conditions		Min.	Typ.	Max.	Unit	
Voltage accuracy			-1.0		+1.0	%	
Line regulation	Low Line to High Line at Full Load	Single	-0.2		+0.2	%	
		Dual	-0.5		+0.5		
Load regulation	No Load to Full Load	Single	-0.2		+0.2	%	
		Dual	-1.0		+1.0		
	10% Load to 90% Load	Single	-0.1		+0.1		
		Dual	-0.8		+0.8		
Cross regulation	Asymmetrical load 25%/100% FL	Dual	-5.0		+5.0	%	
Voltage adjustability	Single output	3.3Vout, 12Vout	-10		+10	%	
		Others	-10		+20		
Ripple and noise	Measured by 20MHz bandwidth					mVp-p	
	With a 10 $\mu$ F/25V X7R MLCC	Single		75			
		Dual	3.3Vout, 5Vout, 5.1Vout		100		
	With a 4.7 $\mu$ F/50V X7R MLCC	Dual	12Vout, 15Vout		100		
		Dual	24Vout		100		
With a 10 $\mu$ F/25V X7R MLCC for each output	Dual	5Vout		75			
		Dual	12Vout, 15Vout		100		
Temperature coefficient			-0.02		+0.02	%/°C	
Transient response recovery time	25% load step change			250		$\mu$ s	
Over voltage protection			3.7		5.4	VDC	
			6.3		7.4		
			13.5		19.6		
			18.3		22.0		
			29.1		32.5		
Over load protection	% of Iout rated; Hiccup mode			160		%	
Short circuit protection			Continuous, automatic recovery				

GENERAL SPECIFICATIONS						
Parameter	Conditions		Min.	Typ.	Max.	Unit
Isolation voltage	1 minute	Input to Output	3000			VDC
		Input (Output) to Case	2250			
Isolation resistance	500VDC		1			G $\Omega$
Isolation capacitance					600	pF
Switching frequency	3.3Vout, 5Vout, 5.1Vout		220	250	280	KHz
	Others		200	230	260	
Safety approvals(Pending)			IEC /EN/ UL62368-1			
Standard approvals(Pending)			EN50155			
			EN45545-2			
Case material			Copper			
Base material			FR4 PCB			
Potting material			Silicone (UL94 V-0)			
Weight			16.1g (0.57oz)			
MTBF	MIL-HDBK-217F, Full load		1.928 x 10 <sup>6</sup> hrs			

ENVIRONMENTAL SPECIFICATIONS						
Parameter	Conditions		Min.	Typ.	Max.	Unit
Operating ambient temperature	Standard type	With derating	-40		+105	°C
	M3 version	With derating	-55		+105	
Maximum case temperature					105	°C
Over temperature protection				115		°C
Storage temperature range			-55		+125	°C
Thermal impedance	Natural convection	Without Heat-sink		13.7		°C/W
		With Heat-sink	HC1	12.9		
			HC2	10.8		
		HC3		9.3		
Thermal shock						MIL-STD-810F
Shock						EN61373, MIL-STD-810F
Vibration						EN61373, MIL-STD-810F
Relative humidity						5% to 95% RH

EMC SPECIFICATIONS			
Parameter	Conditions		Level
EMI	EN55032, EN50121-3-2	With external components	Class A, Class B
EMS	EN55035, EN50121-3-2		
ESD	EN61000-4-2	Air $\pm$ 8kV and Contact $\pm$ 6kV	Perf. Criteria A
Radiated immunity	EN61000-4-3	20 V/m	Perf. Criteria A
Fast transient	EN61000-4-4	$\pm$ 2kV	Perf. Criteria A
	RCD10-36□□□U	With an aluminum electrolytic capacitor (Nippon chemi-con KY series, 220 $\mu$ F/100V) and a TVS (SMDJ120A, 120V, 3000Watt peak pulse power) in parallel.	
	RCD10-72□□□U	With an aluminum electrolytic capacitor (Nippon chemi-con KXJ series, 150 $\mu$ F/200V) and a TVS (SMDJ170A, 170V, 3000Watt peak pulse power) in parallel.	
Surge	EN61000-4-5	EN55035: $\pm$ 1kV and EN50121-3-2: $\pm$ 2kV	Perf. Criteria A
	RCD10-36□□□U	With an aluminum electrolytic capacitor (Nippon chemi-con KY series, 220 $\mu$ F/100V) and a TVS (SMDJ120A, 120V, 3000Watt peak pulse power) in parallel.	
	RCD10-72□□□U	With an aluminum electrolytic capacitor (Nippon chemi-con KXJ series, 150 $\mu$ F/200V) and a TVS (SMDJ170A, 170V, 3000Watt peak pulse power) in parallel.	
Conducted immunity	EN61000-4-6	10 Vr.m.s	Perf. Criteria A
Power frequency magnetic field	EN61000-4-8	100A/m continuous; 1000A/m 1 second	Perf. Criteria A

**CAUTION:** This power module is not internally fused. An input line fuse must always be used.

## CHARACTERISTIC CURVE

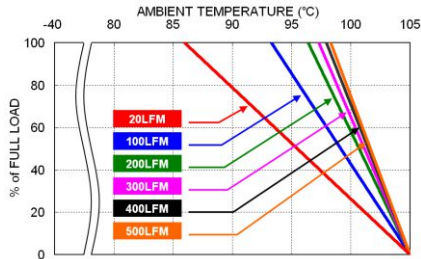

RCD10-72S5P1U Derating Curve

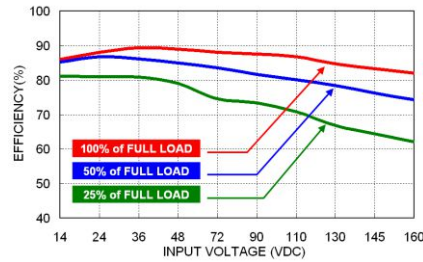

RCD10-72S5P1U Efficiency vs. Input Voltage

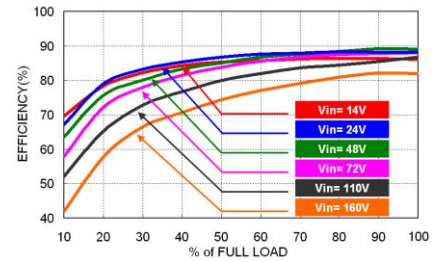

RCD10-72S5P1U Efficiency vs. Output Load

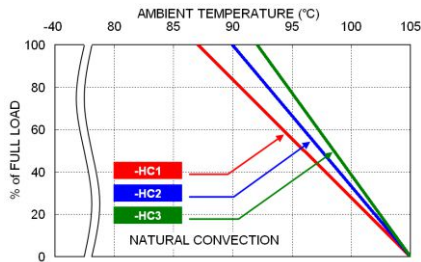

RCD10-72S5P1U Derating Curve with Heat-sink

## FUSE CONSIDERATION

This power module is not internally fused. An input line fuse must always be used.

This encapsulated power module can be used in a wide variety of applications, ranging from simple stand-alone operation to an integrated part of sophisticated power architecture.

To maximum flexibility, internal fusing is not included; however, to achieve maximum safety and system protection, always use an input line fuse.

The input line fuse suggest as below :

Modules	Fuse Rating (A)	Fuse Type
RCD10-36□□□U	2	Slow-Blow
RCD10-72□□□U	1.6	Slow-Blow

The table based on the information provided in this data sheet on inrush energy and maximum DC input current at low Vin..

## MECHANICAL DRAWING

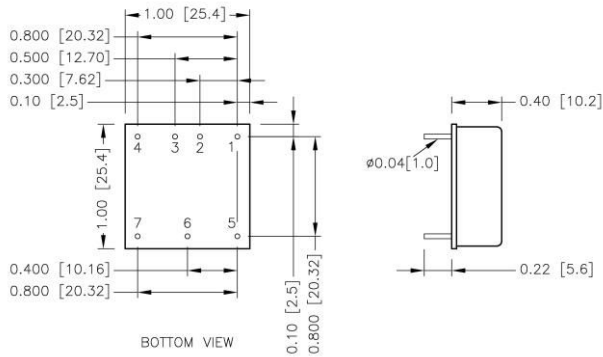

### PIN CONNECTION

PIN	SINGLE	DUAL
1	No Pin/ Bus/ UVP	No Pin/ Bus/ UVP
2	+Vin	+Vin
3	-Vin	-Vin
4	Ctrl	Ctrl
5	+Vout	+Vout
6	Trim	Common
7	-Vout	-Vout

- All dimensions in inch [mm]
- Tolerance :x.xx±0.02 [x.xx±0.5]  
x.xxx±0.01 [x.xx±0.25]
- Pin dimension tolerance ±0.004[0.10]

## RECOMMENDED PAD LAYOUT

### Standard

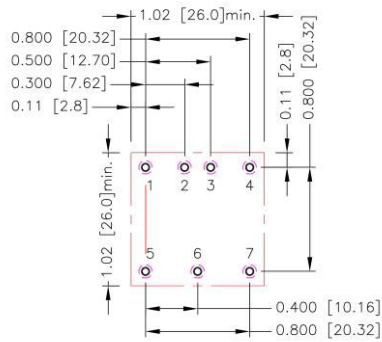

### -HC1、-HC2、-HC3

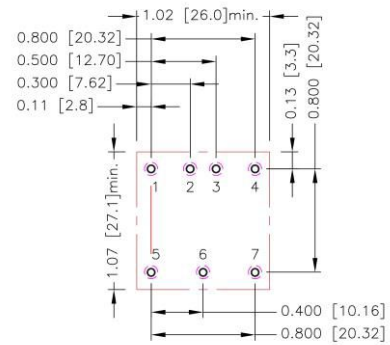

All dimensions in inch[mm]  
 Pad size(lead free recommended)  
 Through hole 1.2.3.4.5.6:  $\Phi 0.051[1.30]$   
 Top view pad 1.2.3.4.5.6:  $\Phi 0.064[1.63]$   
 Bottom view pad 1.2.3.4.5.6:  $\Phi 0.102[2.60]$

## THERMAL CONSIDERATIONS

The power module operates in a variety of thermal environments. However, sufficient cooling should be provided to help ensure reliable operation of the unit. Heat is removed by conduction, convection, and radiation to the surrounding environment. Proper cooling can be verified by measuring the point as the figure below. The temperature at this location should not exceed “Maximum case temperature”. When operating, adequate cooling must be provided to maintain the test point temperature at or below “Maximum case temperature”. You can limit this temperature to a lower value for extremely high reliability.

- Thermal test condition with vertical direction by natural convection (20LFM).

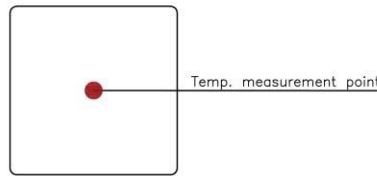

TOP VIEW

## HEAT-SINK TYPE OPTIONS

RCD10-□□□□□U-**HC1**  
7GA0117P01-F

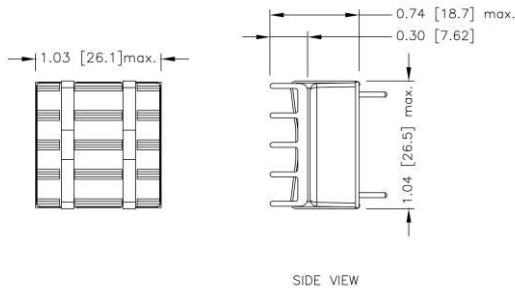

RCD10-□□□□□U-**HC2**  
7GA0118P01-F

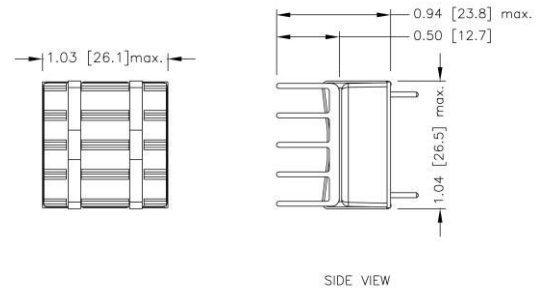

RCD10-□□□□□U-**HC3**  
7GA0119P01-F

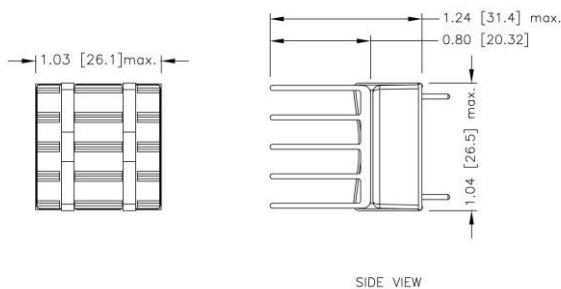

- All dimensions in inch [mm]
- Tolerance :x.xx±0.02 [x.x±0.5]  
x.xxx±0.010 [x.xx±0.25]

## TYPICAL APPLICATION

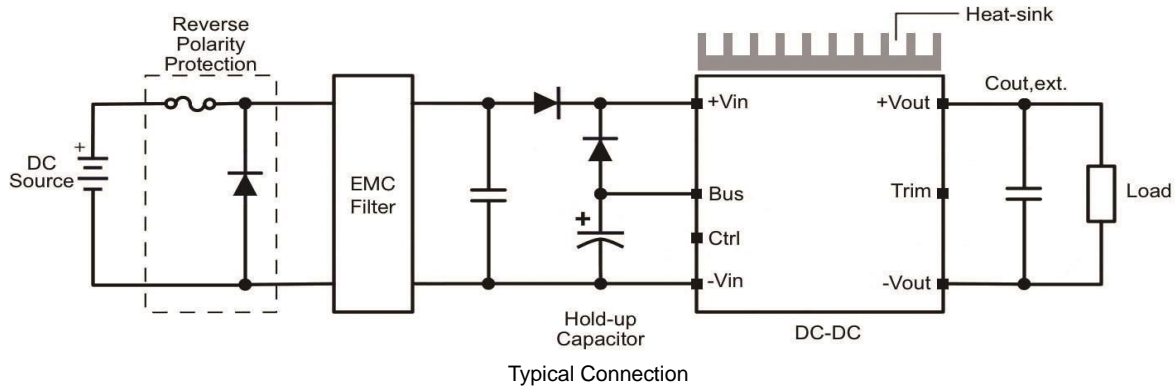

### UVLO

This series product has ultra wide input range. It could cover many kind of nominal input voltage in one module. In order to preventing incorrect operating under different input system, it offers UVLO adjustment by connecting a resistor to set UVLO threshold.

### UVLO Constants

Model	A	B	C
RCD10-36□□□U	14804	144000	16500
RCD10-72□□□U	22330	321000	24000

### UVLO Equation

Start-up Voltage

$$V_{\text{start-up}} = \left( 0.8 + \frac{A \times R_{\text{UVLO}}}{A + R_{\text{UVLO}}} \times 5 \times 10^{-6} \right) \times \left( 1 + B \times \frac{C + R_{\text{UVLO}}}{C \times R_{\text{UVLO}}} \right)$$

Shutdown Voltage

$$V_{\text{shutdown}} = 0.785 \times \left( 1 + B \times \frac{R_{\text{UVLO}} + C}{R_{\text{UVLO}} \times C} \right)$$

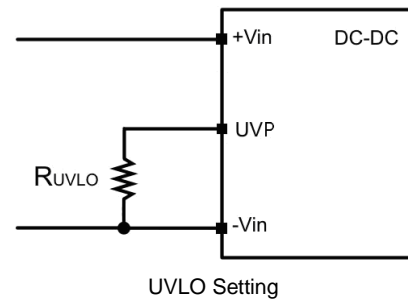

### UVLO values for various nominal input voltage and R<sub>UVLO</sub> table

#### RCD10-36□□□U

Nominal Vin	12 V	24 V	36 V	48 V
Start-up voltage	8.5 V	14.8 V	22.0 V	29.2 V
Shutdown voltage	7.6 V	13.8 V	20.9 V	28.0 V
UVLO Setting resistor	OPEN	18.3 KΩ	8.54 KΩ	5.57 KΩ

#### RCD10-72□□□U

Nominal Vin	24 V	36 V	48 V	72 V	96 V	110 V
Start-up voltage	14.8 V	22 V	29.2 V	43.6 V	58.0 V	66.4 V
Shutdown voltage	13.0 V	20.0V	27.1 V	41.2 V	55.3 V	63.6 V
UVLO Setting resistor	151.5 KΩ	28.87 KΩ	15.95 KΩ	8.42 KΩ	5.72 KΩ	4.82 KΩ

### Hold Up Time

Generally, connecting a large number of hold up capacitors on input are necessary to get a long duration of hold up time for S2, C2 described in EN50155. The Bus pin features excellent function can simply connect capacitors to Bus pin with less quantity of capacitors. It helps reduce layout area and smooth the inrush current.

For further information, please contact P-DUKE.

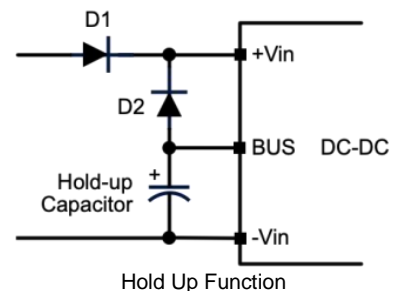



## OUTPUT VOLTAGE ADJUSTMENT

Output voltage set point adjustment allows the user to increase or decrease the output voltage set point of the module. This is accomplished by connecting an external resistor between the Trim pin and either the +Output or -Output pins. With an external resistor between the Trim and -Output pin, the output voltage set point increases. With an external resistor between the Trim and +Output pin, the output voltage set point decreases. The external Trim resistor needs to be at least 1/16W of rated power.

### Trim Up Equation

$$R_U = \left[ \frac{G \times L}{(V_{o,up} - L - K)} - H \right] \Omega$$

### Trim Down Equation

$$R_D = \left[ \frac{(V_{o,down} - L) \times G}{(V_o - V_{o,down})} - H \right] \Omega$$

### Trim Constants

Module	G	H	K	L
RCD10-□□S3P3U	5110	2050	0.8	2.5
RCD10-□□S05U	5110	2050	2.5	2.5
RCD10-□□S5P1U	5110	2050	2.6	2.5
RCD10-□□S12U	10000	5110	9.5	2.5
RCD10-□□S15U	10000	5110	12.5	2.5
RCD10-□□S24U	56000	13000	21.5	2.5

## EXTERNAL OUTPUT TRIMMING

Output can be externally trimmed by using the method shown below.

### Trim-up

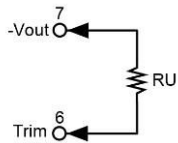

#### □□S3P3U

ΔV (%)	1	2	3	4	5	6	7	8	9	10
Vout (V)	3.333	3.366	3.399	3.432	3.465	3.498	3.531	3.564	3.597	3.630
RU (kΩ)	385.071	191.511	126.990	94.730	75.374	62.470	53.253	46.340	40.963	36.662

#### □□S05U

ΔV (%)	1	2	3	4	5	6	7	8	9	10
Vout (V)	5.050	5.100	5.150	5.200	5.250	5.300	5.350	5.400	5.450	5.500
RU (kΩ)	253.450	125.700	83.117	61.825	49.050	40.533	34.450	29.888	26.339	23.500

ΔV (%)	11	12	13	14	15	16	17	18	19	20
Vout (V)	5.550	5.600	5.650	5.700	5.750	5.800	5.850	5.900	5.950	6.000
RU (kΩ)	21.177	19.242	17.604	16.200	14.983	13.919	12.979	12.144	11.397	10.725

#### □□S5P1U

ΔV (%)	1	2	3	4	5	6	7	8	9	10
Vout (V)	5.151	5.202	5.253	5.304	5.355	5.406	5.457	5.508	5.559	5.610
RU (kΩ)	248.440	123.195	81.447	60.573	48.048	39.698	33.734	29.261	25.782	22.999

ΔV (%)	11	12	13	14	15	16	17	18	19	20
Vout (V)	5.661	5.712	5.763	5.814	5.865	5.916	5.967	6.018	6.069	6.120
RU (kΩ)	20.721	18.824	17.218	15.842	14.649	13.605	12.684	11.866	11.133	10.474

#### □□S12U

ΔV (%)	1	2	3	4	5	6	7	8	9	10
Vout (V)	12.120	12.240	12.360	12.480	12.600	12.720	12.840	12.960	13.080	13.200
RU (kΩ)	203.223	99.057	64.334	46.973	36.557	29.612	24.652	20.932	18.038	15.723

#### □□S15U

ΔV (%)	1	2	3	4	5	6	7	8	9	10
Vout (V)	15.150	15.300	15.450	15.600	15.750	15.900	16.050	16.200	16.350	16.500
RU (kΩ)	161.557	78.223	50.446	36.557	28.223	22.668	18.700	15.723	13.409	11.557

ΔV (%)	11	12	13	14	15	16	17	18	19	20
Vout (V)	16.650	16.800	16.950	17.100	17.250	17.400	17.550	17.700	17.850	18.000
RU (kΩ)	10.042	8.779	7.711	6.795	6.001	5.307	4.694	4.149	3.662	3.223

#### □□S24U

ΔV (%)	1	2	3	4	5	6	7	8	9	10
Vout (V)	24.240	24.480	24.720	24.960	25.200	25.440	25.680	25.920	26.160	26.400
RU (kΩ)	570.333	278.667	181.444	132.833	103.667	84.222	70.333	59.917	51.815	45.333

ΔV (%)	11	12	13	14	15	16	17	18	19	20
Vout (V)	26.640	26.880	27.120	27.360	27.600	27.840	28.080	28.320	28.560	28.800
RU (kΩ)	40.030	35.611	31.872	28.667	25.889	23.458	21.314	19.407	17.702	16.167

## OUTPUT VOLTAGE ADJUSTMENT(CONTINUED)

Trim-down

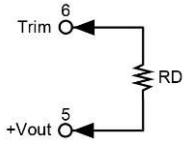

**S3P3U**

$\Delta V$ (%)	1	2	3	4	5	6	7	8	9	10
Vout (V)	3.267	3.234	3.201	3.168	3.135	3.102	3.069	3.036	3.003	2.970
RD (k $\Omega$ )	116.719	54.779	34.133	23.810	17.616	13.486	10.537	8.325	6.604	5.228

**S05U**

$\Delta V$ (%)	1	2	3	4	5	6	7	8	9	10
Vout (V)	4.950	4.900	4.850	4.800	4.750	4.700	4.650	4.600	4.550	4.500
RD (k $\Omega$ )	248.340	120.590	78.007	56.715	43.940	35.423	29.340	24.778	21.229	18.390

**S5P1U**

$\Delta V$ (%)	1	2	3	4	5	6	7	8	9	10
Vout (V)	5.049	4.998	4.947	4.869	4.845	4.794	4.743	4.692	4.641	4.590
RD (k $\Omega$ )	253.350	123.095	79.677	57.968	44.942	36.258	30.056	25.404	21.786	18.891

**S12U**

$\Delta V$ (%)	1	2	3	4	5	6	7	8	9	10
Vout (V)	11.880	11.760	11.640	11.520	11.400	11.280	11.160	11.040	10.920	10.800
RD (k $\Omega$ )	776.557	380.723	248.779	182.807	143.223	116.834	97.985	83.848	72.853	64.057

**S15U**

$\Delta V$ (%)	1	2	3	4	5	6	7	8	9	10
Vout (V)	14.850	14.700	14.550	14.400	14.250	14.100	13.950	13.800	13.650	13.500
RD (k $\Omega$ )	818.223	401.557	262.668	193.223	151.557	123.779	103.938	89.057	77.483	68.223

**S24U**

$\Delta V$ (%)	1	2	3	4	5	6	7	8	9	10
Vout (V)	23.760	23.520	23.280	23.040	22.800	22.560	22.320	22.080	21.840	21.600
RD (k $\Omega$ )	4947.667	2439.333	1603.222	1185.167	934.333	767.111	647.667	558.083	488.407	432.667