



# P-DUKE POWER

## TAD125 Series

2 X 3 Inch AC-DC POWER SUPPLIES  
Up to 125 Watts

**3**  
YEARS  
WARRANTY

ROHS  
COMPLIANT

REACH  
COMPLIANT

+85°C  
-40°C  
AMBIENT TEMP.



Automation



Datacom



IPC



Industry



Measurement



Telecom



Automobile



Boat



Charger



Medical



PV



Railway

UL US CB CE UK CA



PEAK  
POWER

3000  
VAC  
Reinforced  
Insulation

ADJ.  
Output  
Voltage

Internal  
EN55032  
Class  
Filter **B**

LOW  
Leakage  
Current

LOW  
Standby  
Power

Protection  
Class I  
Class II

Operating  
Altitude  
5000  
meter

OCP

OVP

SCP

### PART NUMBER STRUCTURE

T	A	D	125	U	S	12	B	-	□	□	□
Application	Package Code	Dimension Code	Output Power (W)	Input Voltage (VAC)	Output Quantity	Output Voltage (VDC)	Protection Type	Connector Options	Application Options	Conformal Coating Options	
Industry Application	A: Open type U: U chassis type E: Enclosed type D: Din rail type			U: Universal 85 ~ 264VAC	S: Single	12: 12V 15: 15V 18: 18V 24: 24V 28: 28V 36: 36V 48: 48V	B: CLASS II □: CLASS I	□: JST M: Molex T: Terminal Block	□: None C: OVC III □	□: None R: Conformal Coating	

**TECHNICAL SPECIFICATION** All specifications are typical at 230VAC input, full load and 25°C unless otherwise noted

Model Number	Input Range VAC	Output Voltage VDC	Output Current		Input Power No Load W	Efficiency %	Maximum Capacitor Load µF
			Natural Convection A	Forced Air Cooling With 400LFM A			
TAD125US12B TUD125US12B TED125US12B TDD125US12B	85 ~ 264	12	8.34	10.42	0.3	91	8700
TAD125US15B TUD125US15B TED125US15B TDD125US15B	85 ~ 264	15	6.67	8.34	0.3	92	5600
TAD125US18B TUD125US18B TED125US18B TDD125US18B	85 ~ 264	18	5.56	6.95	0.3	92	3900
TAD125US24B TUD125US24B TED125US24B TDD125US24B	85 ~ 264	24	4.17	5.21	0.3	92	2200
TAD125US28B TUD125US28B TED125US28B TDD125US28B	85 ~ 264	28	3.58	4.47	0.3	92	1600
TAD125US36B TUD125US36B TED125US36B TDD125US36B	85 ~ 264	36	2.78	3.48	0.3	91	1000
TAD125US48B TUD125US48B TED125US48B TDD125US48B	85 ~ 264	48	2.09	2.61	0.3	91	550

**INPUT SPECIFICATIONS**

Parameter	Conditions	Min.	Typ.	Max.	Unit
Operating input voltage range	AC input	85		264	VAC
	DC input	120		370	VDC
Input frequency	AC input	47		63	Hz
Input current	100VAC and Full Load			1.8	A
	240VAC and Full Load			0.7	
No load input power	230VAC			0.3	Watts
Leakage current	264VAC			300	µA
Power Factor		0.95			
Start up time				1000	ms
Rise time			20		ms
Hold up time	115VAC and Full Load	18			ms
Input inrush current	230VAC			100	A
Input protection	Internal fuse			T3.15A/250VAC	

OUTPUT SPECIFICATIONS						
Parameter	Conditions		Min.	Typ.	Max.	Unit
Output power	Forced air cooling with 400LFM				125	Watts
	Natural convection				100	
Output peak power	Peak power				140	Watts
	Peak power (130~264Vac)				150	Watts
	Peak power time			10		s
	Peak power duty			20		%
	Average operation power ( % of Full Load)			55		%
Initial set voltage accuracy	230VAC and Full Load		-1.0		+1.0	%
Line regulation	Low Line to High Line at Full Load		-0.2		+0.2	%
Load regulation	No Load to Full Load		-0.5		+0.5	%
	10% Load to 90% Load		-0.4		+0.4	
Voltage adjustability	Trim down over than -10% with 0.25W dummy load		-20		+10	%
Minimum load				0		%
Ripple and noise	Measured by 20MHz bandwidth					mVp-p
	With a 10 $\mu$ F/25V 1206 X7R MLCC	12Vout		140		
		15Vout		150		
	With a 1 $\mu$ F/50V 1206 X7R MLCC	24Vout		160		
		28Vout		180		
		36Vout		190		
With a 0.1 $\mu$ F/100V 1206 X7R MLCC	48Vout		340			
Temperature coefficient			-0.02		+0.02	%/°C
Transient response	Load step from 50 ~ 75% change at 2.5A/ $\mu$ s	Peak deviation			3	% Vout
		Recovery time		500		$\mu$ s
Over voltage protection	% of Vout(nom); Latch mode		115		135	%
Over load protection	% of Iout rated; Hiccup mode		120		160	%
Short circuit protection			Continuous, automatic recovery			

GENERAL SPECIFICATIONS						
Parameter	Conditions		Min.	Typ.	Max.	Unit
Isolation voltage	1 minute (Reinforced insulation)		Input to Output	3000		VAC
			Input (Output) to F.G.	1500		
Isolation resistance	500VDC		0.1			G $\Omega$
Switching frequency				60		kHz
Safety approvals	IEC/ EN/ UL 62368-1 (OVC III)					UL:E193009 CB:UL(Demko)
Weight			TAD		156g (5.50oz)	
			TUD		194g (6.84oz)	
			TED		210g (7.41oz)	
			TDD		232g (8.18oz)	
MTBF	MIL-HDBK-217F Ta=25°C, Full load					7.903 x 10 <sup>5</sup> hrs

ENVIRONMENTAL SPECIFICATIONS						
Parameter	Conditions		Min.	Typ.	Max.	Unit
Operating case temperature	Natural convection and Full load (with derating)					°C
	-40°C start up : 80% Load,max. @ Vin > 100VAC		-40		+85	
	-40°C start up : 100% Load,max. @ Vin > 200VAC					
Storage temperature range			-40		+85	°C
Operating altitude					5000	m
Shock						IEC60068-2-27
Vibration						IEC60068-2-6
Relative humidity	Non-condensing					5% to 95% RH

**EMC SPECIFICATIONS**

Parameter	Conditions	Level
EMI	EN55032 and FCC Part 15 External components may be required for class I application.	Conducted ClassB Radiated ClassA
Harmonic currents	EN61000-3-2 Full Load	Class A and D
Voltage flicker	EN61000-3-3	
EMS	EN55035	
ESD	EN61000-4-2	Perf. Criteria A
Radiated immunity	EN61000-4-3 20 V/m	Perf. Criteria A
Fast transient	EN61000-4-4 $\pm 2kV$	Perf. Criteria A
Surge	EN61000-4-5 DM $\pm 1kV$ and CM $\pm 2kV$	Perf. Criteria A
Conducted immunity	EN61000-4-6 20 Vr.m.s	Perf. Criteria A
Power frequency magnetic field	EN61000-4-8 10 A/m	Perf. Criteria A
Dip and interruptions	EN61000-4-11	

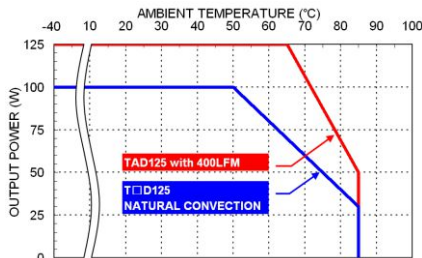
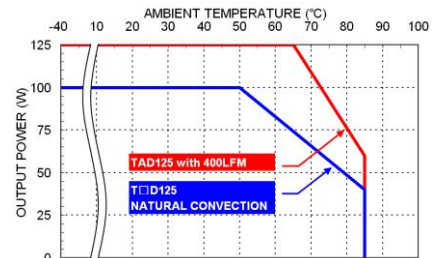
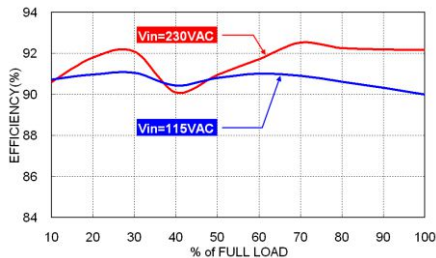
**CHARACTERISTIC CURVE**

 Derating Curve vs. Ambient Temperature  
 Vin=115VAC

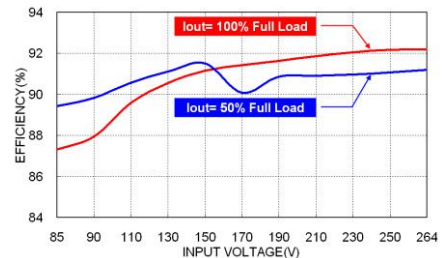
 Derating Curve vs. Ambient Temperature  
 Vin=230VAC

TAD125US24B Efficiency vs. Output Load

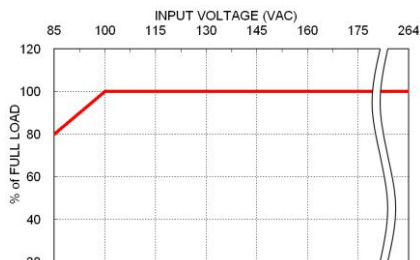

TAD125US24B Efficiency vs. Input Voltage



 TAD125 Derating Curve vs. Input Voltage  
 Forced air cooling with 400LFM

**MECHANICAL DRAWING**

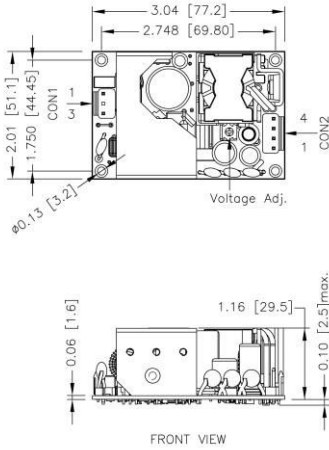
**TAD** Open type

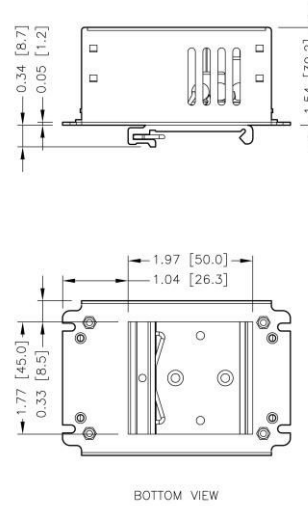

**TDD** Din rail type



1.All dimensions in inch [mm]

Tolerance :  $x.xx \pm 0.02 [x.xx \pm 0.5]$   $x.xxx \pm 0.01 [x.xx \pm 0.25]$

2.The screw locked torque: MAX 3.4Kgf-cm/0.33N-m

1.All dimensions in inch [mm]

Tolerance :  $x.xx \pm 0.02 [x.xx \pm 0.5]$   $x.xxx \pm 0.01 [x.xx \pm 0.25]$

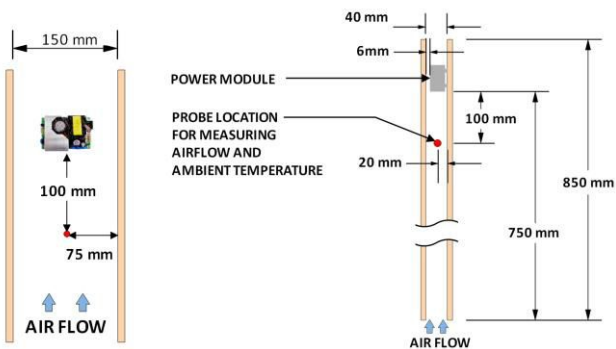
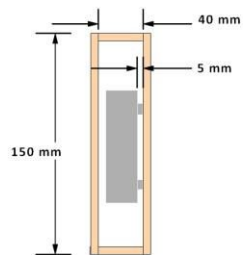

**CONNECTORS CONNECTIONS**

CON1 – Input Connector

Pin 1	Line
Pin 3	Neutral

CON2 – Output Connector

Pin 1,2	-Vout
Pin 3,4	+Vout

\*Either one of four screws holes of Open / Chassis type can be considered as PE connection for CLASS I application.

## MECHANICAL DRAWING(CONTINUED)

**TED** Enclosed type

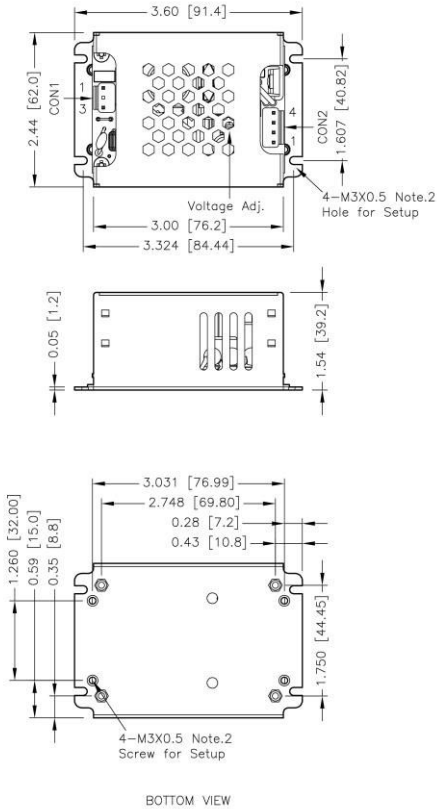

**TUD** U chassis type

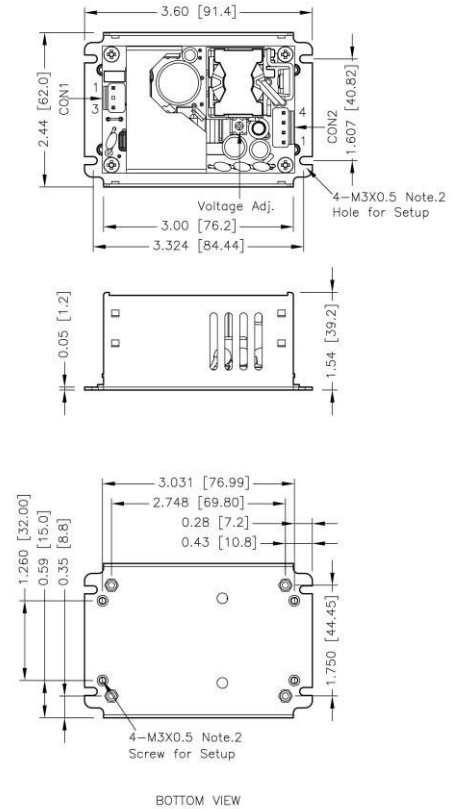

- 1.All dimensions in inch [mm]  
Tolerance : x.xx±0.02 [x.x±0.5] x.xxx±0.01 [x.xx±0.25]
- 2.The screw locked torque: MAX 4.2Kgf-cm/0.41N-m

- 1.All dimensions in inch [mm]  
Tolerance : x.xx±0.02 [x.x±0.5] x.xxx±0.01 [x.xx±0.25]
- 2.The screw locked torque: MAX 4.2Kgf-cm/0.41N-m



### CONNECTORS CONNECTIONS

CON1 – Input Connector	
Pin 1	Line
Pin 3	Neutral

CON2 – Output Connector	
Pin 1,2	-Vout
Pin 3,4	+Vout

\*Either one of four screws holes of Open / Chassis type can be considered as PE connection for CLASS I application.

### CONNECTOR OPTIONS

Blank:	JST Type	-M	Molex Type	-T	Terminal Block
	Mates with housing CON1: <b>VHR-3N</b> CON2: <b>VHR-4N</b>  Crimp terminals CON1: <b>SVH-21T-P1.1</b> CON2: <b>SVH-21T-P1.1</b>		Mates with housing CON1: <b>09-50-8031</b> CON2: <b>09-50-8041</b>  Crimp terminals CON1: <b>SD-2478</b> CON2: <b>SD-2478</b>		<b>Screw locked torque</b> <b>MAX 2Kgf.cm/0.2N.m</b>  <b>Wire dimension range</b> <b>26 ~ 16AWG</b>